



IMPORTANT

Verify if your machine is hydraulically proportional or motor controlled.

Motor controller machines can be identified by the MC label located on the side of the machine or on the platform control box.



For motor controller-specific diagrams, schematics and troubleshooting information, see [Section 6 - Appendix A](#).



SERVICE MANUAL (ANSI/CSA)

DC ELECTRIC SCISSORS

MODELS **SJIII 3220** **SJIII 3226** **SJIII 4620** **SJIII 4626** **SJIII 4632**

157928AM April 2019

SKYJACK[™]

This manual is based on Serial Number(s):

SJIII 3220 60 002 259 to 60 999 999
SJIII 3226 27 006 432 to 27 999 999
SJIII 46xx 70 007 139 to 70 999 999

Please refer to the website www.skyjack.com for older Serial Numbers.

Skyjack Service Center

3451 Swenson Ave. St. Charles,
Illinois, 60174 USA
Phone: 630-262-0005
Toll Free: 1-800-275-9522
Fax: 630-262-0006
Email: service@skyjack.com

Parts (North America)

Toll Free: 1-800-965-4626
Toll Free Fax: 1-888-782-4825
E-mail: parts@skyjack.com

Skyjack Australia Pty Ltd.

Unit 1, 35 Honeycomb Drive
Eastern Creek
New South Wales 2766
Australia
Tel: +61 (0) 2 9854 0700
Fax: +61 (0) 2 9854 0777

Parts & Service (Europe)

Unit 1 Maes Y Clawdd
Maesbury Road Industrial Estate
Oswestry, Shropshire SY10 8NN UK
Phone: +44-1691-676-235
Fax: +44-1691-676-238
E-mail: info@skyjackeurope.co.uk

Skyjack Brasil

Alameda Júpiter, 710
Loteamento American Park Empresarial
Indaiatuba, SP, Brasil 13347-653
Tel: +55 19 3936 0132

SERVICE AND MAINTENANCE

Table of Contents

Section 1 - Scheduled Maintenance

[Table of Contents](#)

Section 2 - Maintenance Tables and Diagrams

[Table of Contents](#)

Section 3 - System Component Identification and Schematics

[Table of Contents](#)

Section 4 - Troubleshooting Information

[Table of Contents](#)

Section 5 - Procedures

[Table of Contents](#)

Section 6 - Motor Controller

[Table of Contents](#)

The Safety Alert Symbol identifies important safety messages on aerial platforms, safety signs in manuals or elsewhere. When you see this symbol, be alert to the possibility of personal injury or death. Follow the instructions in the safety message.



This Safety Alert Symbol means attention!

Become alert! Your safety is involved.



DANGER

DANGER indicates an imminently hazardous situation which, if not avoided, will result in death or serious injury.



WARNING

WARNING indicates a potentially hazardous situation which, if not avoided, could result in death or serious injury.



CAUTION

CAUTION indicates a potentially hazardous situation which, if not avoided, may result in minor or moderate injury. It may also be used to alert against unsafe practices.

IMPORTANT

IMPORTANT indicates a procedure) essential for safe operation and which, if not followed, may result in a malfunction or damage to the aerial platform.

Section 1 - SCHEDULED MAINTENANCE

Operator’s Responsibility for Maintenance

- Aerial Platform and Mobile Elevating Work Platform Definition8
- Purpose of Equipment8
- Use of Equipment8
- Manuals8
- Service Policy and Warranty8
- Operator Safety Reminders, Warnings and Precautions8
- Maintenance and Inspection Schedule9
- Owner’s Annual Inspection Record9
- Replacement Parts9
- Maintenance and Service Safety Tips9
- Hydraulic System & Component Maintenance and Repair10
- Maintenance Hints11
- Railing Maintenance and Repair11

Service and Maintenance

- About this Section12
- Service Bulletins12
- Maintenance and Inspection12
- Maintenance Instructions12

Tables

- Table 1.1 Owner’s Annual Inspection Record13
- Table 1.2 Pre-Delivery/Maintenance Inspection Checklist14

Scheduled Maintenance

- 1.1 Scheduled Maintenance Inspections15
- 1.2 Function Tests24

SKYJACK is continuously improving and expanding product features on its equipment, therefore, specifications and dimensions are subject to change without notice.

Aerial Platform and Mobile Elevating Work Platform Definition

A mobile device that has a positionable platform supported from ground level by a structure.

Purpose of Equipment

The SKYJACK SJIII DC Electric series aerial platforms are designed to transport and raise personnel, tools and materials to overhead work areas.

Use of Equipment

The aerial platform is a highly maneuverable, mobile work station. Work platform elevation and elevated driving must only be done on a firm level surface.

Manuals

Operating

The operating manual is considered a fundamental part of the aerial platform. It is a very important way to communicate necessary safety information to users and operators. A complete and legible copy of this manual must be kept in the provided weather-resistant storage compartment on the aerial platform at all times.

Service & Maintenance

The purpose of this is to provide the customer with the servicing and maintenance procedures essential for the promotion of proper machine operation for its intended purpose.

All information in this manual should be read and understood before any attempt is made to service the machine. The updated copy of the manuals are found on the company's website: www.skyjack.com.

Service Policy and Warranty

SKYJACK warrants each new SJIII Series work platform to be free of defective parts and workmanship for the first 24 months. Any defective part will be replaced or repaired by your local SKYJACK dealer at no charge for parts or labor. Contact the SKYJACK Service Department for warranty statement extensions or exclusions.

Operator Safety Reminders, Warnings and Precautions

Operator safety is SKYJACK's priority. The operator should comply with all applicable safety-related reminders, warnings and precautions found in the Operating Manual. They should be read and understood completely before operating the aerial platform.

Maintenance and Inspection Schedule

The actual operating environment of the work platform governs the use of the maintenance schedule. The inspection points covered in [Table 1.2 Pre-Delivery/Maintenance Inspection Checklist](#). Maintenance and Inspection Checklist, indicates the areas of the aerial platform to be maintained or inspected and at what intervals the maintenance and inspections are to be performed.

Owner's Annual Inspection Record

It is the responsibility of the owner to arrange quarterly and annual inspections of the aerial platform. [Table 1.1](#). Owner's Annual Inspection Record is to be used for recording the date of the inspection, owner's name, and the person responsible for the inspection of the work platform.

Replacement Parts

Use only original replacement parts. Parts such as batteries, wheels, railings, etc. with weight and dimensions different from original parts will affect stability of the aerial platform and must not be used without manufacturer's consent.

All replacement tires must be of the same size and load rating as originally supplied tires; to maintain safety and stability of aerial platform.

Consult SKYJACK's Service Department for optional tires specifications and installation.



WARNING

Any unit that is damaged or not operating properly must be immediately tagged and removed from service until proper repairs are completed.

Maintenance and Service Safety Tips

Maintenance and repair should only be performed by personnel who are trained and qualified to service this aerial platform.

All maintenance and service procedures should be performed in a well lighted and well ventilated area.

Anyone operating or servicing this aerial platform must read and completely understand all operating instructions and safety hazards in this manual and operating manual.

All tools, supports and lifting equipment to be used must be of proper rated load and in good working order before any service work begins. Work area should be kept clean and free of debris to avoid contaminating components while servicing.

All service personnel must be familiar with employer and governmental regulations that apply to servicing this type of equipment.

Keep sparks and flames away from all flammable or combustible materials.

Properly dispose of all waste material such as lubricants, rags, and old parts according to the relative law provisions obtaining in the country.

Before attempting any repair work, turn Battery Disconnect Switch to the "OFF" position.

Preventive maintenance is the easiest and least expensive type of maintenance.

Hydraulic System & Component Maintenance and Repair

The following points should be kept in mind when working on the hydraulic system or any component:



WARNING

Escaping fluid from a hydraulic pressure leak can damage your eyes, penetrate the skin and cause serious injury. Use proper personal protection at all times.

1. Any structure has limits of strength and durability. To prevent failure of structural parts of hydraulic components, relief valves which limit pressure to safe operating values are included in the hydraulic circuits.
2. Tolerance of working parts in the hydraulic system is very close. Even small amounts of dirt or foreign materials in the system can cause wear or damage to components, as well as general faulty operation of the hydraulic system. Every precaution must be taken to assure absolute cleanliness of the hydraulic oil.
3. Whenever there is a hydraulic system failure which gives reason to believe that there are metal particles or foreign materials in the system, drain and flush the entire system and replace the filter cartridges. A complete change of oil must be made under these circumstances.
4. Whenever the hydraulic system is drained, check the magnets in the hydraulic reservoir for metal particles. If metal particles are present, flush the entire system and add a new change of oil. The presence of metal particles also may indicate the possibility of imminent component failure. A very small amount of fine particles is normal.
5. All containers and funnels used in handling hydraulic oil must be absolutely clean. Use a funnel when necessary for filling the hydraulic oil reservoir, and fill the reservoir only through the filter opening. The use of cloth to strain the oil should be avoided to prevent lint from getting into the system.
6. When removing any hydraulic component, be sure to cap and tag all hydraulic lines involved. Also, plug the ports of the removed components.

NOTE

Samples of hydraulic oil should be drawn from the reservoir and tested annually. These samples should be taken when the oil is warmed through normal operation of the system. The sample should be analyzed by a qualified lubrication specialist to determine if it is suitable for continued use. Oil change intervals will depend on the care used in keeping the oil clean, and the operating conditions. Dirt and/or moisture contamination will dictate that the oil should be changed more often. Under normal use and operating conditions, the hydraulic oil should be changed every two years. Refer to [Table 1.2 Pre-Delivery/Maintenance Inspection Checklist](#) of this manual.

7. All hydraulic components must be dis-assembled in spotlessly clean surroundings. During disassembly, pay particular attention to the identification of parts to assure proper reassembly. Clean all metal parts in a clean mineral oil solvent. Be sure to thoroughly clean all internal passages. After the parts have been dried thoroughly, lay them on a clean, lint-free surface for inspection.
8. Replace all O-rings and seals when overhauling any component. Lubricate all parts with clean hydraulic oil before reassembly. Use small amounts of petroleum jelly to hold O-rings in place during assembly.
9. Be sure to replace any lost hydraulic oil when completing the installation of the repaired component, and bleed any air from the system when required.
10. All hydraulic connections must be kept tight. A loose connection in a pressure line will permit the oil to leak out or air to be drawn into the system. Air in the system can cause damage to the components and noisy or erratic system operation.

Maintenance Hints

Three simple maintenance procedures have the greatest effect on the hydraulic system performance, efficiency and life. Yet, the very simplicity of them may be the reason they are so often overlooked. What are they? Simply these:

1. Change filters annually. The filters will need to be changed more often depending on the operating conditions. Dirty, dusty, high moisture environments may cause the hydraulic system to be contaminated more quickly.
2. Maintain a sufficient quantity of clean hydraulic oil of the proper type and viscosity in the hydraulic reservoir.
3. Keep all connections tight.

Railing Maintenance and Repair

Skyjack MEWPs have been designed to ensure compliance with the relevant design standards applicable for that particular unit at the time of manufacture. As such, any repairs made to the guardrail or basket structure need to ensure this compliance is not compromised and must return the structure to its original condition.

Any damage must be repaired by returning the railing assembly to its undamaged state. Damage includes, but is not limited to, the items listed below:

- bent/deformed guardrail sections
- cracks or broken welds in railing sections
- damaged pin connections
- missing pins or broken pin lanyards
- missing railing hardware
- loose or missing parts
- additional holes in guardrail sections other than those approved by Skyjack

Additionally, the guardrails must be properly positioned and secured, and the entry gate/chain must be in good working order.

The strength of the guardrail system, and therefore its ability to provide fall protection for platform occupants, depends upon the design being secure and undamaged.

Skyjack railings are designed for modular replacement, and Skyjack recommends replacement of any damaged railing section. Skyjack-approved replacement parts will meet this requirement.

To improve the resistance of extension railing assemblies to damage, Skyjack approves modification of the guardrail assembly by a qualified person, in the manner outlined in the procedure titled: [5.1-5 Railing Modification to Enhance Resistance to Damage](#).

About this Section

This section contains the maintenance and inspection schedule that is to be performed.

References are made to the procedures in Section 5 that outline detailed step-by-step instructions for checks and replacements.

Service Bulletins

Before performing any scheduled maintenance inspection procedure, refer to service bulletins found in our web site: www.skyjackinc.com for updates related to service and maintenance of this aerial platform.

Maintenance and Inspection

Death or injury can result if the aerial platform is not kept in good working order. Inspection and maintenance should be performed by competent personnel who are trained and qualified on maintenance of this aerial platform.



WARNING

Failure to perform each procedure as presented and scheduled may cause death, serious injury or substantial damage.

NOTE

Preventive maintenance is the easiest and least expensive type of maintenance.

- Unless otherwise specified, perform each maintenance procedure with the aerial platform in the following configuration:
 - Aerial platform parked on a flat and level surface
 - Disconnect the battery by turning the main power disconnect switch to the "OFF" position.
- Repair any damaged or malfunction components before operating aerial platform.
- Keep records on all inspections.

Maintenance Instructions

This manual consists of four schedules to be done for maintaining on an aerial platform. Inspection schedule frequency is shown below:

Inspection Schedule

PDI / Frequent	B
Annual	B + C
Additional	*

- B** - Perform PDI prior to each delivery, or Frequent Inspection every 3 months or 150 hours.
- C** - Perform Scheduled Maintenance Inspections every year.
- *** - Perform at time sensitive maintenance intervals.
 - Make copies of the maintenance and inspection checklist to be used for each inspection.
 - Check the schedule on the checklist for the type of inspection to be performed.
 - Place a check in the appropriate box after each inspection procedure is completed.
 - Use the maintenance and inspection checklist and step-by-step procedures in [Section 1](#) to perform these inspections.
 - If any inspection receives a fail, tag and remove the aerial platform from service.
 - If any aerial platform component(s) has been repaired, an inspection must be performed again before removing the tag. Place a check in the repair column.

Legend

P = Pass
F = Fail
R = Repaired
N/A = Not applicable



Pre-Delivery/Maintenance Inspection Checklist
Vertical Mast, SJIII, & Rough Terrain

Serial Number: _____ Product Owner: _____
 Model: _____
 Hourmeter Reading: _____ Product User: _____
 Date/Time: _____

Use this form for Pre-Delivery Inspections (PDI) prior to each rental, lease or sale, or as a guide for all Frequent Inspections and Annual Inspections. Refer to the applicable Operating and Service Manuals for inspection details (eg. Visual Inspection and Function Tests, Torque Specs., Engine Oil, Chain Inspection Intervals, etc.).

Inspection Type Schedule

<input type="checkbox"/> PDI	B
<input type="checkbox"/> Frequent	B
<input type="checkbox"/> Annual	B + C

B - Perform PDI prior to each delivery or Frequent Inspections every 3 months or 150 hrs. For further details refer to Service & Operating Manuals.
C - Perform Scheduled Maintenance Inspections every year. For further details refer to Service & Operating Manuals.

P - Pass
F - Fail
R - Repaired
N/A - Not Applicable

Check the appropriate box as each item is inspected. If an item is found to be not acceptable, please describe the issue in the comments box provided.

Items for Inspection	P	F	R	N/A
Refer to skyjack.com for the latest service bulletins.	B			
Ensure Annual Inspection has been completed within the last 13 months.	B			
Manuals & Required Documents. In storage box, in good condition & legible.	B			
Labels. In place, secure & legible.	B			
Limit Switches. Secured & no obstructions or damage.	B			
Main Power Disconnect Switch. Cables secure & in working order.	B			
Battery/ Hydraulic Tray. Latch is secure, & no missing parts.	B			
Battery Charger. Secure, & no damage.	B			
Battery. No damage, tight connections, fluid levels correct. Clean terminals and cable ends.	B			
Manifolds. Tight fittings and hoses & no damage or leaks. Tight wire connections & no missing parts.	B, C			
Motor Controller. Secure & no damage. No loose connections.	B			
Electrical Panel / Control Module. Secure & no damage. Tight wire connections and fasteners.	B			
Hydraulic Tank. Filler cap secure & no damage or leaks.	B			
Hydraulic Oil. Level at, or slightly above top mark.	B, C			
Hydraulic Components & Hoses. Secure & no damage or leaks.	B			
Base Weldment. No deformation or cracks.	B			
Base Control Switches. Switches to neutral position & no damage.	B			
Free-wheeling Valve Knob. Secure & no damage or missing parts.	B			
Ladder. Secure & no damage.	B			
AC Power to Platform (Plug Cord Receptacle). No obstructions, dirt or damage.	B			
Pothole Protection Device. Check both sides for obstructions, dirt, or damage.	B			
Brakes. Secure & no damage or leaks.	B, C			
Steer Cylinder Assembly. Secure & no damage, leaks or missing parts.	B			
Wheel/Tire Assembly. Check all tires for damage, wear & proper alignment. Lug nuts torqued as recommended.	B			
Axles. Secure & no missing parts. Tight fittings and hoses & no leaks.	B			
Tie Rod. End studs locked & no damage.	B			
Tilt (Load) Sensor. Secure & no damage.	B			
Emergency Lowering Access Rod. Secure & no damage.	B			
Engine Tray. No damage or missing parts.	B			

Items for Inspection	P	F	R	N/A
Engine Control Console. Secure & no damage.	B			
Engine Air Filter. No damage or missing parts.	B, C			
Engine Oil. Level between "L" and "H". Ensure oil change interval has not been exceeded.	B			
Radiator. Secure & no damage or missing parts. Check coolant level.	B, C			
Muffler and Exhaust. Secure & no damage.	B			
Fuel Shut-off Valve. No damage or missing parts.	B			
Fuel Tank. Filler cap is secure & no damage.	B			
Fuel Leaks. Tight fittings and hoses & no damage or leaks.	B			
Propane Tank. Straps fastened to brackets & coupler tight.	B			
Propane Tank Leaks. No leaks (refer to service manual for procedure).	B			
Scissor Assembly. No deformation/damage. Pins secure. Cables & wires routed with no damage.	B			
Mast Assembly. No damage or deformation. Lubricated	B, C			
Mast Chains. No damage or missing parts.	B, C			
Control Cables. No damage or missing parts.	B, C			
Rollers. Secure & no obstructions, dirt, or damage/wear.	B, C			
Wear Pads. No damage/wear or missing parts. Fasteners tightened.	B, C			
Scissor Bumpers. Secure & no damage.	B			
Sliders. Secure & no obstructions, dirt, or damage/wear.	B			
Maintenance Support. Secure & no damage.	B			
Lift Cylinder(s). No damage or missing parts. Tight fittings and hoses & no leaks.	B			
Scissor Pins. No damage/wear or missing parts.	B			
Platform Control Console. Switches to neutral position & secure. No missing parts.	B			
Railings and Gate/Chain. Secure & no damage or missing parts.	B			
Lanyard Attachment Anchorage. Attachment rings secure & no damage.	B			
AC Outlet. No obstructions, dirt, or damage.	B			
Powered Extension Control Console. Switches to neutral position & secure. No missing parts.	B			
Extension Deck. Secure & no damage or missing parts. Check fluid level (if applicable).	B			
Outriggers. No damage or missing parts.	B			
Scissor Guards. Secure & no damage.	B			
Greasing Points. No obstructions, dirt, or damage.	B, C			
Function Tests (Refer to your corresponding Serial #'s Operating Manual for information on running these tests.)				
	<input type="checkbox"/>	<input type="checkbox"/>	<input type="checkbox"/>	<input type="checkbox"/>
	<input type="checkbox"/>	<input type="checkbox"/>	<input type="checkbox"/>	<input type="checkbox"/>

Comments:

The undersigned confirms that all areas listed have been inspected, and any and all discrepancies have been brought to the attention of the owner. Furthermore, the undersigned confirms that all discrepancies have been corrected prior to using this machine.

Owner: _____ / _____ / _____
 Print Name Signature Date (DD/MM/YY)
 User: _____ / _____ / _____
 Print Name Signature Date (DD/MM/YY)

Note: Visit skyjack.com for a printable copy of this form.

167830AC



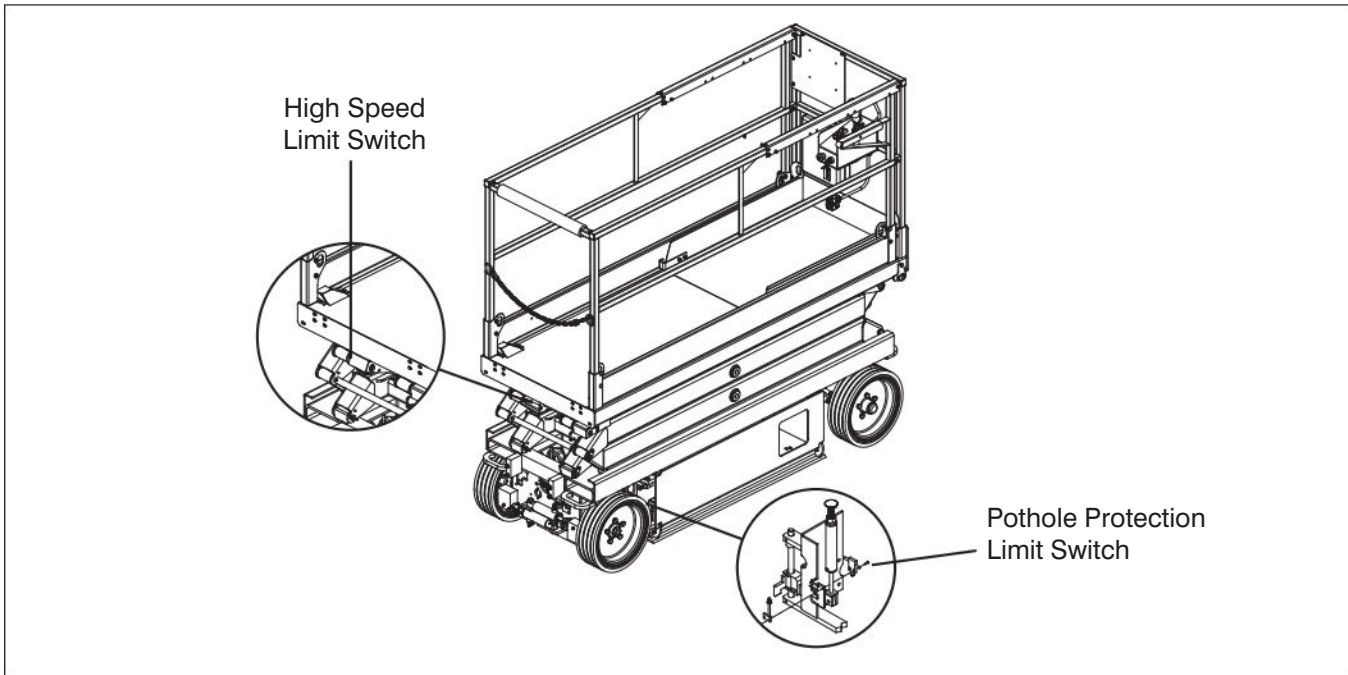

1.1 Scheduled Maintenance Inspections

Begin the scheduled maintenance inspections by checking each item in sequence for the conditions listed in this section.



WARNING

To avoid injury, do not operate an aerial platform until all malfunctions have been corrected.



WARNING

To avoid possible injury, ensure aerial platform power is off during your visual and daily maintenance inspections.

Electrical

Maintaining the electrical components is essential to good performance and service life of the aerial platform.

Inspect the following areas for chafed, corroded and loose wires:

- base to platform cables and wiring harness
- battery tray wiring harnesses
- hydraulic/electrical wiring harnesses

Hydraulic

Maintaining the hydraulic components is essential to good performance and service life of the aerial platform.

Perform a visual inspection around the following areas:

- hoses and fittings
- all hydraulic cylinders
- all hydraulic manifolds
- the underside of the base
- ground area under the aerial platform

1.1-1 Manuals (B)

Ensure a copy of operating manual and other important documents are enclosed in manual storage box.

- Check to be sure manual storage box is present and in good condition.
- Ensure manuals are legible and in good condition.
- Always return manuals to the manual storage box after use.

1.1-2 Labels (B)

Refer to the labels section in the operating manual and determine that all labels are in place and are legible.

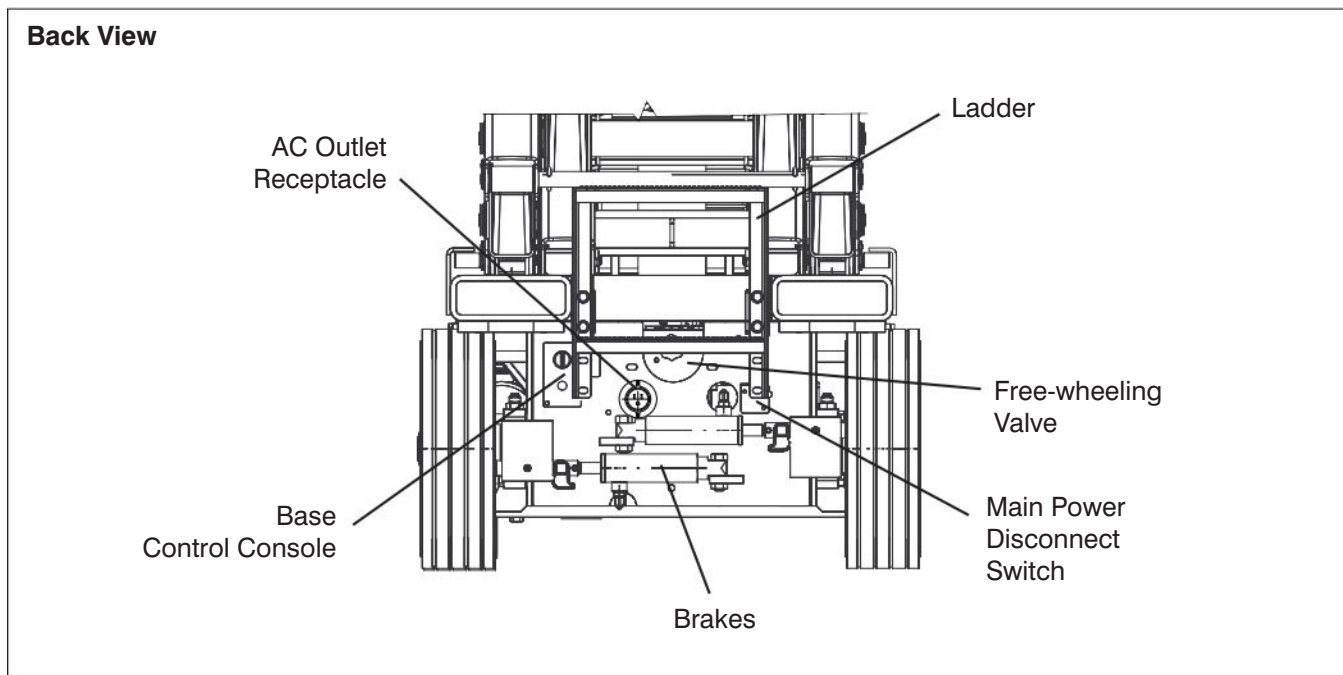

1.1-3 Limit Switches (B)

Detecting limit switch malfunction is essential to safe aerial platform operation. Ensure limit switches are properly secured and movement is not obstructed.

Visually inspect all limit switch located inside the scissor arms and the outrigger assemblies for the following:

- broken or missing actuator arm
- missing fasteners
- loose wire connections

1.1-4 Entrance Side

- **Main Power Disconnect Switch (B)**

- Turn main power disconnect switch to "O" off position.
- Ensure all cables are secure and switch is in proper working condition.

- **Base Control Switches (B)**

- Ensure there are no signs of visible damage and all switches are in their neutral positions.

- **Free-wheeling Valve Knob (B)**

- Ensure there are no loose or missing parts and there is no visible damage.

- **Brakes (B, C)**

- Ensure there are no loose or missing parts and there is no visible damage.
- Ensure brake override is not engaged.

- **AC Outlet Receptacle (B)**

- Ensure receptacle is free from dirt and obstructions.

- **Ladder (B)**

- Ensure there are no loose or missing parts and there is no visible damage.

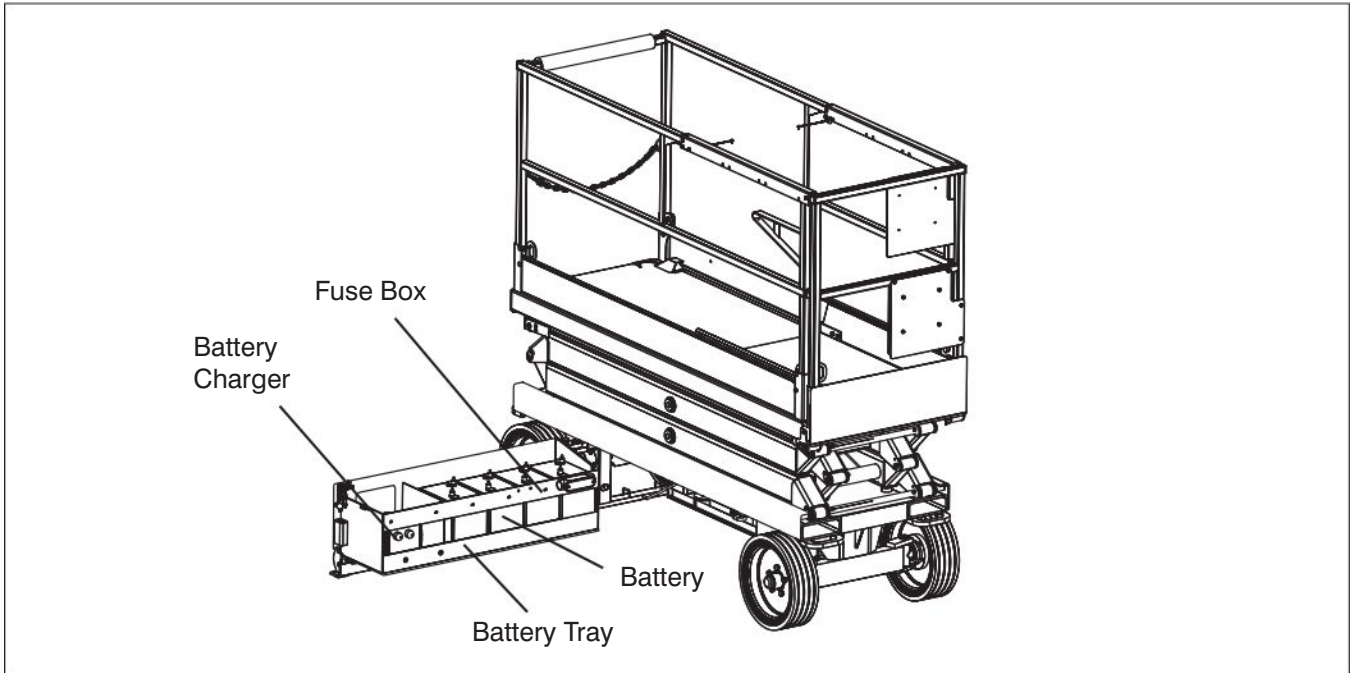

1.1-5 Battery Tray Side

- **Pothole Protection Device (B)**
 - Ensure mechanisms have no sign of visible damage and are free from dirt and obstructions.
- **Battery Tray (B)**
 - Ensure tray latch is secure and in proper working order.
- **Battery Charger (B)**
(Compacts - Entrance Side)
 - Ensure charger is secure and shows no visible damage.
- **Battery (B)**
Proper battery condition is essential to good performance and operational safety. Improper fluid levels or damaged cables and connections can result in component damage and hazardous conditions.

 **WARNING**

Battery acid is extremely corrosive - Wear proper eye and facial protection as well as appropriate protective clothing. If contact occurs, immediately flush with cold water and seek medical attention.

1. Check battery case for damage.
2. **B - Frequent Inspection**
Clean battery terminals and cable ends thoroughly with a terminal cleaning tool or wire brush.
3. Ensure all battery connections are tight.
4. If applicable, check battery fluid level.

B - Frequent Inspection

If plates are not covered by at least 1/2" (13 mm) of solution, add distilled or demineralized water.

5. **B - Frequent Inspection**
Replace battery if damaged or incapable of holding a lasting charge.

 **WARNING**

Explosion hazard. Keep flames and sparks away. Do not smoke near batteries.



 **WARNING**

Use original or manufacturer-approved parts and components for the aerial platform.

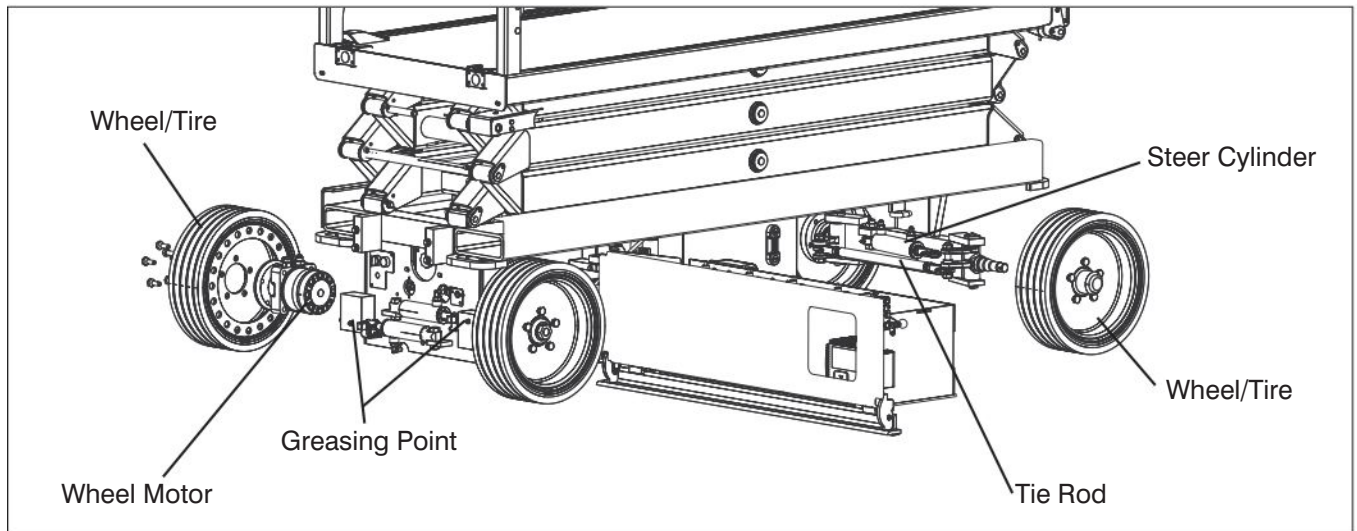

- **Steer Cylinder Assembly (B)**

- Ensure steer cylinder assembly is properly secured and there are no loose or missing parts.
- Ensure there are no signs of hydraulic leakage

- **Wheel/Tire Assembly (B)**

The aerial platform is equipped with solid rubber tires. Tire and/or wheel failure could result in an aerial platform tip-over. Component damage may also result if problems are not discovered and repaired in a timely fashion.

- Check all tire treads and sidewalls for cuts, cracks and unusual wear.
- Check each wheel for damage and cracked welds.
- Check each lug nut for proper torque to ensure none are loose.

B - Frequent Inspection

- For proper torque information, refer to [Table 2.4 Torque Specifications](#).
- Check wheel motor assembly for loose or missing parts and signs of visible damage.
- Ensure wheels are aligned and true vertically and horizontally.
- Ensure each wheel nut has proper torque.
- Ensure the castle nut is in place with cotter pin.



WARNING

Intermixing tires of different types or using tires of types other than those originally supplied with this equipment can adversely affect stability. Therefore, replace tires **ONLY** with exact Skyjack-approved type. Failure to operate with matched approved tires in good condition may result in death or serious injury.

- **Wheel Bolts (If Equipped) (B)**

- Check each wheel bolt for proper torque to ensure none are loose.
- If any wheel bolts are found to be loose or not at the correct torque value ([Table 2.4 Torque Specifications](#)), each component should be inspected to ensure that there is no damage, prior to re-assembly. Do not attempt to re-tighten damaged parts — they must be replaced.
- See [Section 5](#) for procedures.

- **Tie Rod (B)**

- Ensure there are no loose or missing parts, tie rod end studs are locked and there is no visible damage.

- **Greasing Points (B, C)**

- Ensure greasing points have no sign of visible damage and are free from dirt and obstructions.

B - Frequent Inspection

- Locate grease fittings and pump grease as needed.

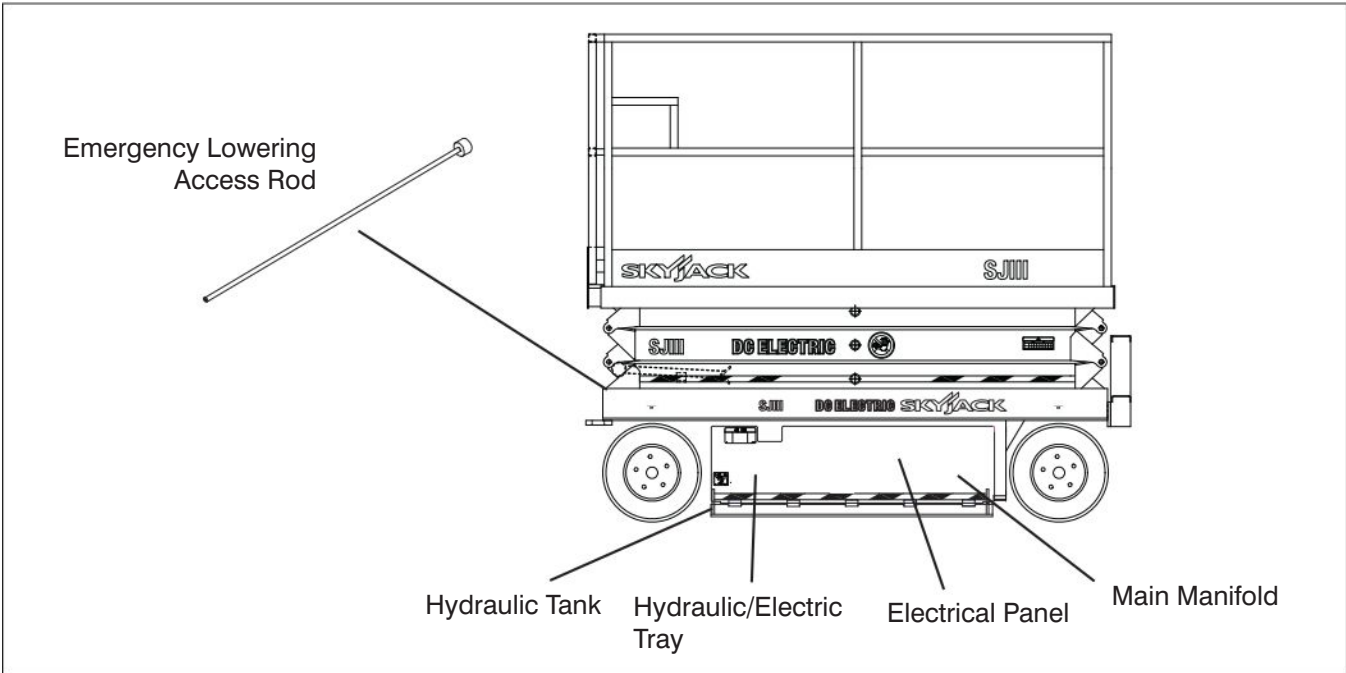

1.1-6 Hydraulic/Electric Tray Side

- Ensure tray latch is secure and in proper working order.
- **Pothole Protection Device (B)**
 - Ensure mechanisms have no sign of visible damage and are free from dirt and obstructions.
- **Hydraulic Tank (B)**
 - Ensure hydraulic filler cap is secure.
 - Ensure tank shows no visible damage and no evidence of hydraulic leakage.
- **Hydraulic Oil (B, C)**
 - Ensure platform is fully lowered, and then visually inspect the sight gauge located on the side of the hydraulic oil tank.
 - The hydraulic oil level should be at or slightly above the top mark of the sight glass.
- **C - Annual Inspection**
 - Refer to Section 1 - Hydraulic System & Component Maintenance and Repair
- **Hydraulic Pump and Motor (B)**
 - Ensure there are no loose or missing parts and there is no visible damage.

- **Electrical Panel (B)**
 - Ensure panel is properly secured and there is no visible damage.
 - Ensure there are no loose wire connections or missing fasteners.
- **Hydraulic Manifolds (B, C)**
 - Ensure all fittings and hoses are properly tightened and there is no evidence of hydraulic leakage.
 - Ensure there are no loose wire connections or missing fasteners.
- **Tilt Sensor (If Equipped) (B)**
 - Ensure tilt sensor is properly secured and there is no visible damage.
- **Load Sensor (If Equipped) (B)**
 - Ensure load sensor is properly secured and there is no visible damage.
- **Emergency Lowering Access Rod (If Equipped) (B)**
 - Ensure rod is properly secured and there is no visible damage.

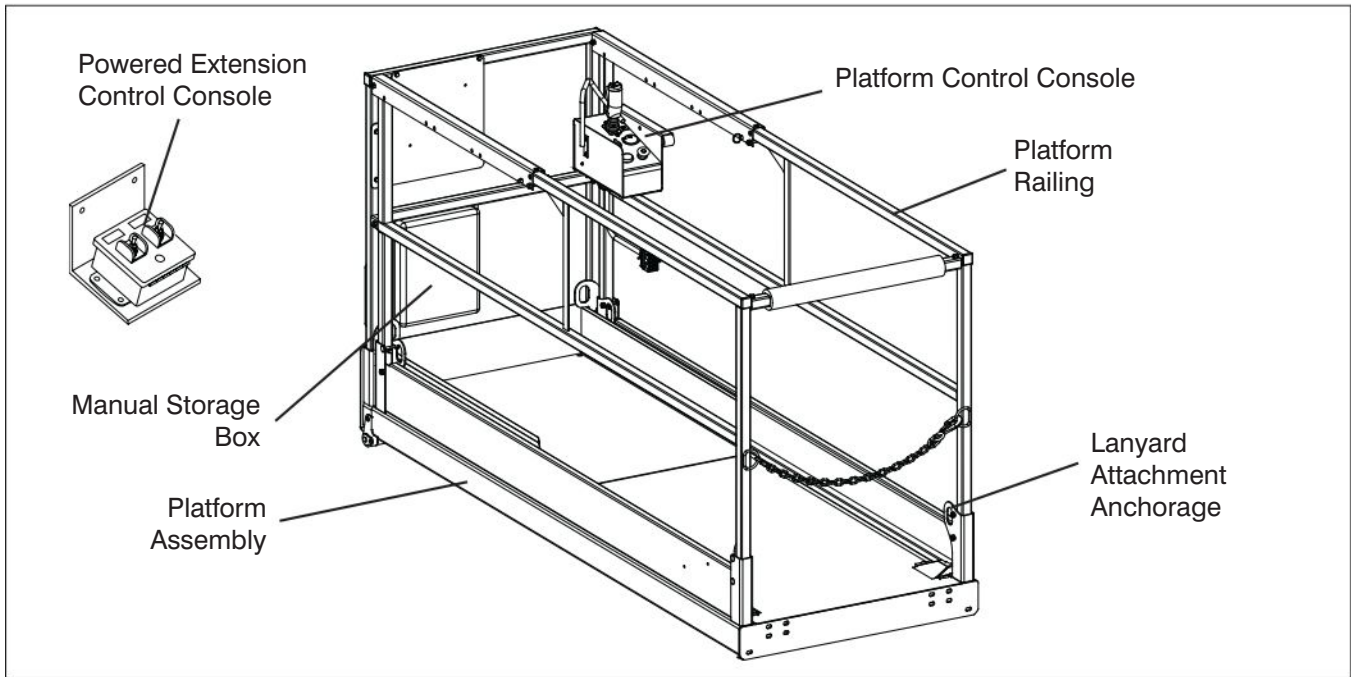

1.1-7 Platform Assembly



WARNING

Ensure that you maintain three points of contact to mount/dismount platform.

1. Use the ladder of aerial platform to access platform.
2. Close the gate/Secure chain.
 - Ensure there are no loose or missing parts and there is no visible damage.
 - Ensure all fasteners are securely in place.
 - Ensure all railings are properly positioned and secured.
 - Ensure gate is in good working order.
- **Lanyard Attachment Anchorage (B)**
 - Ensure attachment rings are secure and no visible damage.
- **AC Outlet on Platform (B)**
 - Ensure outlet has no visible damage and free from dirt or obstructions.

- **Platform Control Console (B)**
 - Ensure all switches and controller are returned to neutral and are properly secured.
 - Ensure there are no loose or missing parts and there is no visible damage.
- **Powered Extension Control Console (If Equipped) (B)**
 - Ensure all switches are returned to neutral and are properly secured.
 - Ensure there are no loose or missing parts and there is no visible damage.



WARNING

Ensure that you maintain three points of contact to mount/dismount platform.

3. Use the ladder to dismount from platform.

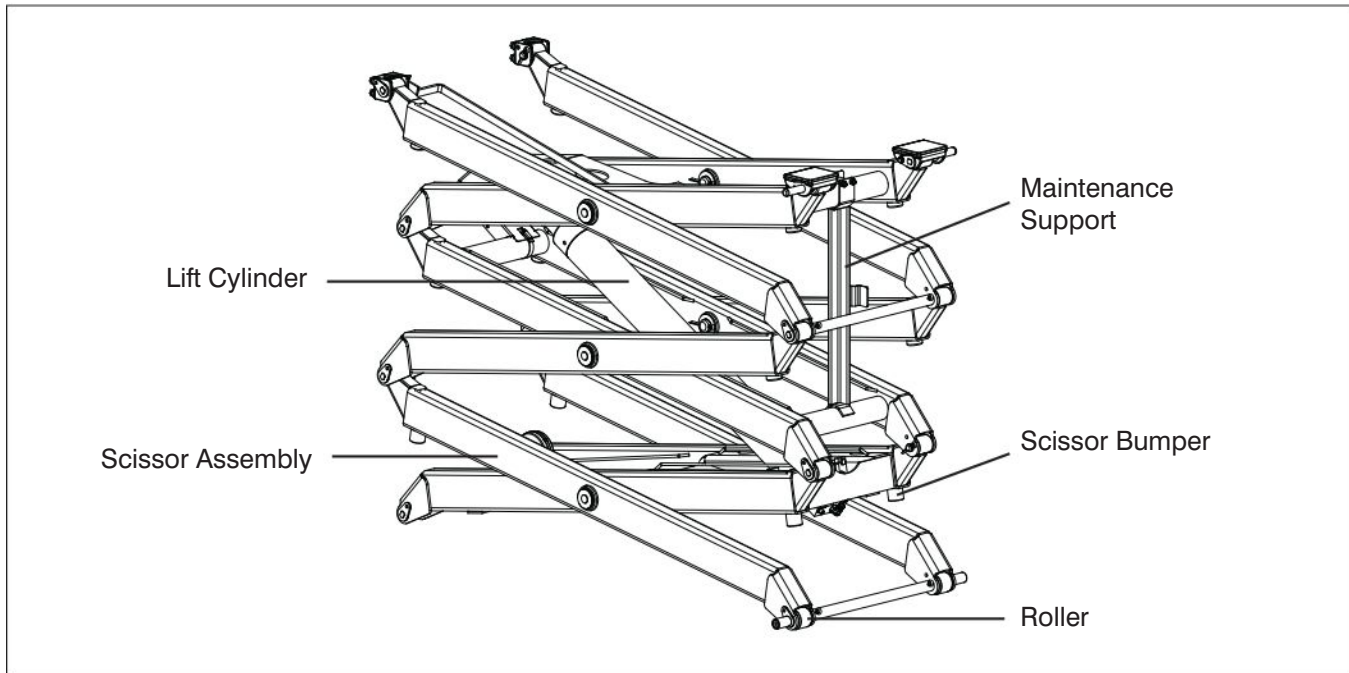

1.1-8 Lifting Mechanism

1. Raise the platform until there is adequate clearance to swing down the maintenance support.

- **Maintenance Support (B)**

- Ensure maintenance support is properly secured and shows no visible damage.

- **Scissor Assembly (B)**

- Ensure scissor assembly shows no visible damage and no signs of deformation in weldments.
- Ensure all pins are properly secured.
- Ensure cables and wires are properly routed and shows no signs of wear and/or physical damage.

- **Scissor Bumpers (B)**

- Ensure bumpers are secure and shows no sign of visible damage.

- **Rollers (B)**

- Ensure rollers are secure and there is no visible damage.
- Ensure rollers' path of travel are free from dirt and obstructions.

- **Scissor Pin Inspection (B)**

- Complete a structural inspection of the scissor pin connections, looking for indicators of pin and/or scissor arm damage. These indicators include, but are not limited to:
 - Noise coming from binding/seized pins
 - Rust forming near pin joint
 - Cracks in welds or in surrounding metal
 - Evidence of metal dust or shavings from wearing components
 - Broken/missing pin retainer bolts
 - Broken/missing pin retainers
 - Rotated pin
 - Elongation/enlargement of pin hole

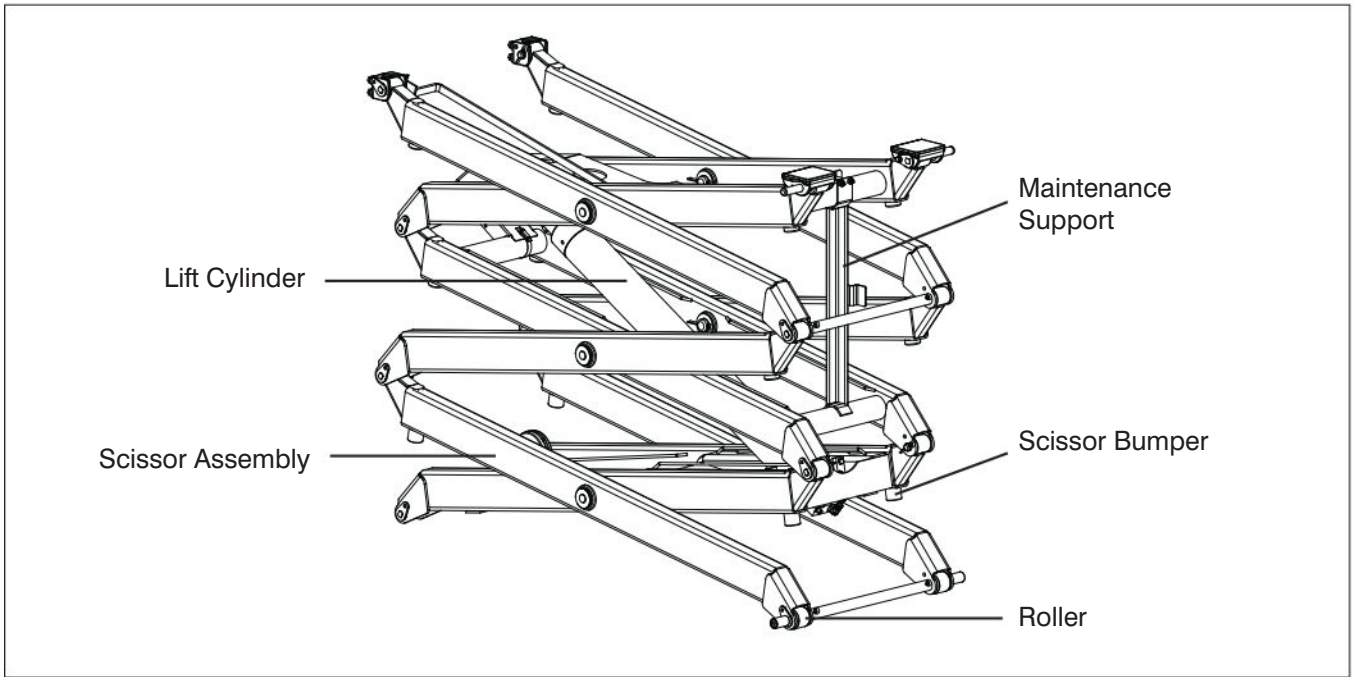

Examples of pivot pin connections with no damage:

- No rust
- Pin has not rotated
- Area is clear of dust/metal shaving
- Pin retainer/retainer bolts are in place

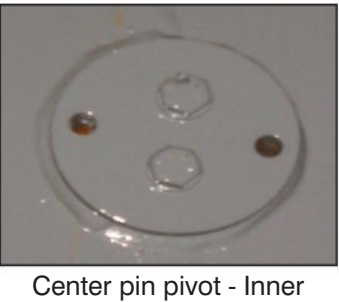
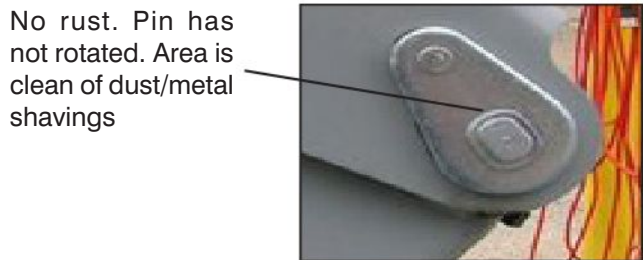
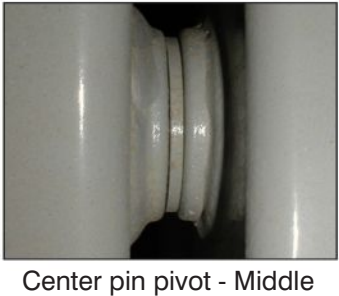
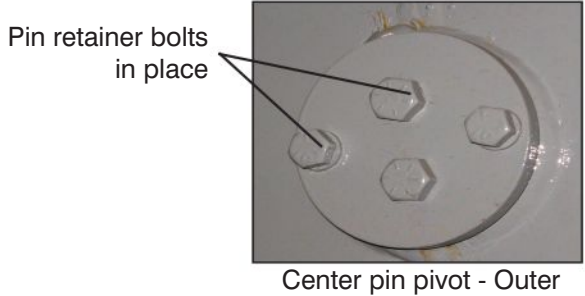

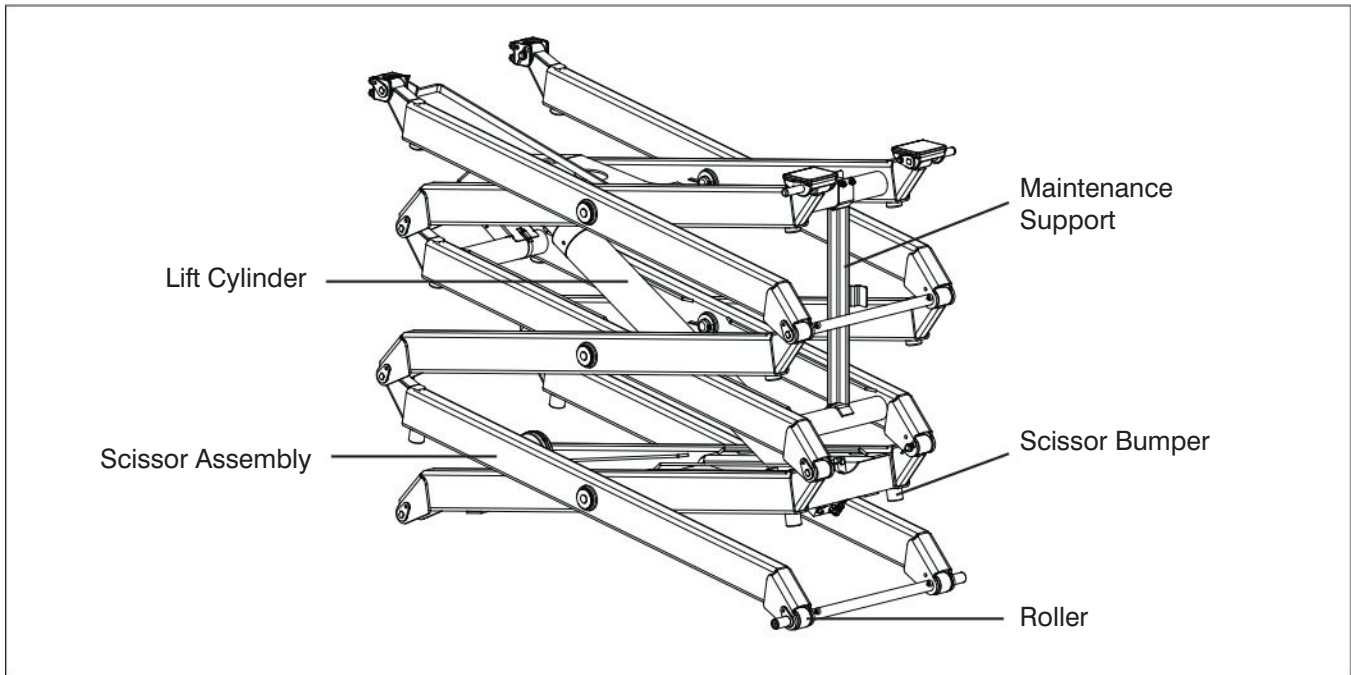

Examples of damaged pin connections:

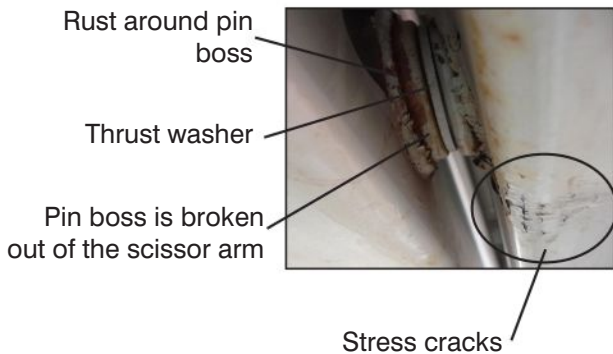
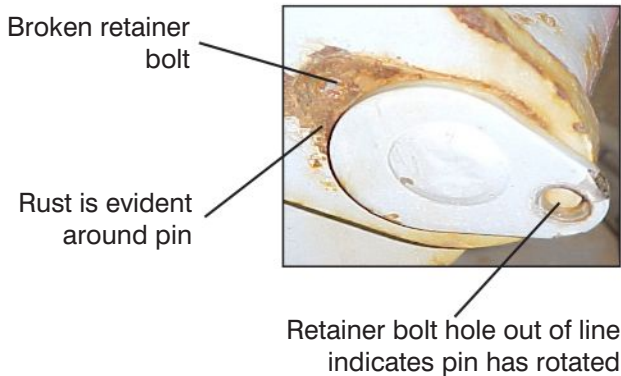

Scissor end pin connections showing symptoms of damage must be inspected after removing the applicable pins and bushings. The scissor bore should also be inspected at this time for any signs of damage, specifically elongation or ovality of the hole. Provided there is no structural damage to

the scissor arms, the pins and bushings can be replaced with new components.

! WARNING

Any units showing the above listed and/or depicted signs of damage should be immediately removed from service and repaired by a qualified technician.

Any units with structural damage to any pin connection or scissor arm must be **immediately removed from service** and repaired by a qualified technician. Contact Skyjack Service for direction on how to repair the unit.

- **Lift Cylinder(s) (B)**
 - Ensure each lift cylinder is properly secured, there are no loose or missing parts and there is no evidence of damage.
 - Ensure all fittings and hoses are properly tightened and there is no evidence of hydraulic leakage.

2. Raise the platform until there is adequate clearance to swing up the maintenance support into storage bracket.
3. Fully lower the platform.

1.2 Function Tests

Function tests are designed to discover any malfunctions before aerial platform is put into service. The operator must understand and follow step-by-step instructions to test all aerial platform functions.



WARNING

Never use a malfunctioning aerial platform. If malfunctions are discovered, aerial platform must be tagged and placed out of service. Repairs to aerial platform may only be made by a qualified service technician.

After repairs are completed, perform a pre-operation inspection and a series of function tests again before putting aerial platform into service.

Prior to performing function tests, be sure to read and understand **Start Operation** section of the operating manual.

For function tests that are to be run, please refer to the operating manual that corresponds to the correct serial number. Here, there will be detailed instructions for which tests to perform, as well as how to properly and successfully perform them.

Section 2 - MAINTENANCE TABLES AND DIAGRAMS

Tables

Table 2.1 Specifications and Features.....	27
Table 2.1 Specifications and Features (Continued)	28
Table 2.2 Floor Loading Pressure.....	29
Floor Loading Pressure	30
Table 2.3 Maximum Platform Capacities (Evenly Distributed)	31
Table 2.4 Torque Specifications	32
Table 2.5 Torque Specifications for Fasteners (Imperial)	33
Table 2.6 Torque Specifications for Fasteners (Metric)	34
Table 2.7 Torque Specifications for Hydraulic Couplings & Hoses.....	35

2

Table 2.1 Specifications and Features

MODEL	3220	3226
Weight *	3510 lb. 1592 kg	4135 lb. 1876 kg
Overall width	32" 0.81 m	32" 0.81 m
Overall length	91" 2.3 m	91" 2.3 m
Platform Size (inside)	28" x 83" 0.71 x 2.1 m	28" x 83" 0.71 x 2.1 m
Height		
Working Height	26' 8.1 m	32' 9.9 m
Platform Elevated Height	20' 6.1 m	26' 7.9 m
Stowed Platform Height	38" 0.97 m	45" 1.1 m
Stowed Height (Railings Up)	82" 2.1 m	89" 2.3 m
Drive Height	FULL	
Standard Operating Time		
Lift Time (No Load)	27 s	47 s
Lower Time (No Load)	41 s	63 s
Lift Time (Rated Load)	33 s	51 s
Lower Time (Rated Load)	29 s	46 s
Chassis		
Normal Drive Speed	1.9 mph 3.0 km/h	2.4 mph 3.8 km/h
Elevated Drive Speed	0.64 mph 1.0 km/h	0.64 mph 1.0 km/h
High Torque Drive Speed	0.95 mph 1.5 km/h	1.2 mph 1.9 km/h
Gradeability (Ramp Angle)	25%	
Tires	16 x 5 x 12 Solid Rubber	
Hydraulic Oil		
Type	ATF Dexron III Shell Naturelle HF-E 32	
Tank Capacity	5.8 gal. 24L	

1059AE_ANSI_Specs_32XX

* Weight with standard 3' (0.9 m) or 4' (1.2 m) extension platform.

Refer to nameplate for aerial platforms with 5' (1.5 m) or 6' (1.8 m) extension platform.

Table 2.1 Specifications and Features (Continued)

MODEL	4620	4626	4632
Weight *	4100 lb. 1860 kg	4700 lb. 2132 kg	5075 lb. 2302 kg
Overall width	46" 1.17 m		
Overall length	91" 2.31 m		
Platform Size (inside)	42" x 84" 1.07 m x 2.13 m		
Height			
Working Height	26' 7.92 m	32' 9.75 m	38' 11.6 m
Platform Elevated Height	20' 6.1 m	26' 7.9 m	32' 9.8 m
Stowed Platform Height	38" 0.97 m	45" 1.14 m	48.5" 1.23 m
Stowed Height Railings Up	77.25" 1.96 m	84.5" 2.15 m	88" 2.24 m
Drive Height	FULL		
Standard Operating Time			
Lift Time (No Load)	24 s	48 s	50 s
Lower Time (No Load)	48 s	45 s	62 s
Lift Time (Rated Load)	32 s	49 s	54 s
Lower Time (Rated Load)	32 s	37 s	57 s
Chassis			
Normal Drive Speed	2.20 mph 3.5 km/h		
Elevated Drive Speed	0.56 mph 0.90 km/h		
High Torque Drive Speed	1.20 mph 1.9 km/h		
Gradeability	25%		
Tires	16 x 5 x 12 Solid Rubber		
Hydraulic Oil			
Type	ATF Dexron III Shell Naturelle HF-E 32		
Tank Capacity	5.8 gal. 24 L		

- * Weight with standard 3' (0.9 m) or 4' (1.2 m) extension platform.
Refer to serial nameplate for specific applications.
1 Fill hardness: 55 Durometer

1059AD_ANSI_Specs_46XX

Table 2.2 Floor Loading Pressure

MODEL		Total Aerial Platform Weight		Total Aerial Platform Load					
				Wheel		LCP**		OUP**	
		lb.	kg	lb.	kg	psi	KPa (kN/m ²)	psf	KPa (kN/m ²)
3220	min*	3400	1542	1396	633	110	758.5	175	8.5
	max*	4299	1950	1936	878	130	896.5	245	11.5
3226	min*	4100	1860	1644	746	120	827.5	210	10.0
	max*	4610	2091	1844	836	130	896.5	235	11.5
4620	min*	4100	1860	1640	744	191	1316.9	146	7.0
	max*	5620	2549	2251	1021	222	1530.6	199	9.5
4626	min*	4700	2132	1880	853	206	1420.3	168	8.0
	max*	5920	2685	2300	1040	224	1544.4	210	10.1
4632	min*	5075	2302	2030	921	208	1434.1	180	8.6
	max*	5775	2620	2310	1048	223	1537.5	205	9.8

1059_ANSI_FL_T4.4AE_AA

* **min** - Total aerial platform weight with no options

max - Aerial platform weight + all options + full capacity

LCP - Locally Concentrated Pressure is a measure of how hard the aerial platform presses on the

** areas in direct contact with the floor. The floor covering (tile, carpet, etc.) must be able to withstand more than the indicated values above.

OUP - Overall Uniform Pressure is a measure of the average load the aerial platform imparts on the whole surface directly underneath it. The structure of the operating surface (beams, etc.) must be able to withstand more than the indicated values above.

NOTE:

The **LCP** or **OUP** that an individual surface can withstand varies from structure to structure and is generally determined by the engineer or architect for that particular structure.

Floor Loading Pressure

Locally Concentrated Pressure (LCP):

Foot Print Area = Length x Width

$$LCP = 0.4 \times \frac{\text{Weight of Aerial Platform} + \text{Capacity}}{\text{Foot Print Area}}$$

Overall Uniform Pressure (OUP):

Base Area = Length x Width

$$OUP = \frac{\text{Weight of Aerial Platform} + \text{Capacity}}{\text{Base Area}}$$

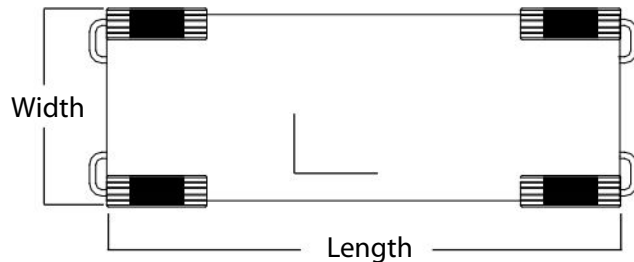
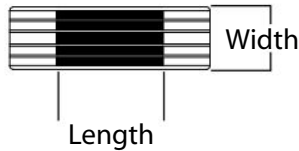

⚠ WARNING

Intermixing tires of different types or using tires of types other than those originally supplied with this equipment can adversely affect stability. Therefore, replace tires only with the exact original Skyjack-approved type. Failure to operate with matched approved tires in good condition may result in death or serious injury.

Table 2.3 Maximum Platform Capacities (Evenly Distributed)

MODEL	Manual Extension Platform				Powered Extension Platform				Maximum Wind Speed	Tilt Cutout Setting
	Total Capacity		Extension Capacity		Total Capacity		Extension Capacity			
3220	900 lb.	2 Persons	300 lb.	1 Person	800 lb.	2 Persons	300 lb.	1 Person	28 mph	1.5 x 3.5
	408 kg		136 kg		363 kg		136 kg		12.5 m/s	
3226	500 lb.	2 Persons	250 lb.	1 Person	N/A				28 mph	1.5 x 3.5
	227 kg		113 kg		12.5 m/s					
4620	1300 lb.	3 Persons	250 lb.	1 Person	N/A				28 mph	2.5 x 4.5
	590 kg		113 kg		12.5 m/s					
4626	1000 lb.	3 Persons	300 lb.	1 Person	1000 lb.	3 Persons	300 lb.	1 Person	28 mph	2.5 x 4.5
	454 kg		136 kg		454 kg		136 kg		12.5 m/s	
4632	700 lb.	2 Persons	250 lb.	1 Person	N/A				28 mph	2.5 x 4.5
	318 kg		113 kg		12.5 m/s					

1059_ANSI_MPC_T4.5AC_AA

NOTE: Overall Capacity - Occupants and materials not to exceed rated load.

Table 2.4 Torque Specifications

Base		Torque		Torque				
Directional Valve Mounting Bolts		2.3-2.7 lb-ft (28-32 lb-in)		3.2 – 3.6 Nm				
Wheel Mounting Bolts		90 lb-ft		122 Nm				
Rear Wheel Castle Nut		70 lb-ft*		95 Nm*				
Rear Wheel Motor Nut		280 lb-ft		380 Nm				
Front Wheel Castle Nut		Finger tight until snug*						
Hydraulic Motor Mounting Bolts		85 lb-ft		115 Nm				
*See section 5 for the full torque procedure.								
Cartridge							Coils	
Valve Size	8	38	58	10	12	16	All coil sizes	
Torque (lb-ft) max	20	20	20	25	35	50	4 to 5	
Torque (lb-in) max	240	240	240	300	420	600	48 to 60	
Torque (Nm) max	27.12	27.12	27.12	33.9	47.46	67.8	5.42 to 6.78	
SAE Plugs								
Port Size	2	4	5	6	8	10	12	16
Torque (lb-ft) max	3	10	15	15	25	25	30	35
Torque (lb-in) max	36	120	180	180	300	300	360	420
Torque (Nm) max	4.07	13.56	20.34	20.34	33.9	33.9	40.68	47.46
Newton-meter = Nm			Pound-foot = lb-ft			Pound-inch = lb-in		
Additional Torque Specifications may be found in Section 3.								

60655AD

Table 2.5 Torque Specifications for Fasteners (Imperial)

IMPERIAL BOLT TORQUE CHART							
Size	Torque Type	SAE 2		SAE 5		SAE 8	
		Dry	Lubed	Dry	Lubed	Dry	Lubed
4-40	(in-lb)	(5)	(4)	(8)	(6)	(12)	(9)
	Nm	0.6	0.5	0.9	0.7	1.4	1.0
4-48	(in-lb)	(6)	(5)	(9)	(7)	(13)	(10)
	Nm	0.7	0.6	1.0	0.8	1.5	1.1
6-32	(in-lb)	(10)	(8)	(16)	(12)	(23)	(17)
	Nm	1.1	0.9	1.8	1.4	2.6	1.9
6-40	(in-lb)	(12)	(9)	(18)	(13)	(25)	(19)
	Nm	1.4	1.0	2.0	1.5	2.8	2.1
8-32	(in-lb)	(19)	(14)	(30)	(22)	(41)	(31)
	Nm	2.1	1.6	3.4	2.5	4.6	3.5
8-36	(in-lb)	(20)	(15)	(31)	(23)	(43)	(32)
	Nm	2.3	1.7	3.5	2.6	4.9	3.6
10-24	(in-lb)	(27)	(21)	(43)	(32)	(60)	(45)
	Nm	3.1	2.4	4.9	3.6	6.8	5.1
10-32	(in-lb)	(31)	(23)	(49)	(36)	(68)	(51)
	Nm	3.5	2.6	5.5	4.1	7.7	5.8
1/4-20	(in-lb) / ft-lb	(66)	(50)	8	(75)	12	9
	Nm	7.5	5.6	11	8.5	16	12
1/4-28	(in-lb) / ft-lb	(76)	(56)	10	(86)	14	10
	Nm	8.6	6.3	14	9.7	19	14
5/16-18	ft-lb	11	8	17	13	25	18
	Nm	15	11	23	18	34	24
5/16-24	ft-lb	12	9	19	14	25	20
	Nm	16	12	26	19	34	27
3/8-16	ft-lb	20	15	30	23	45	35
	Nm	27	20	41	31	61	47
3/8-24	ft-lb	23	17	35	25	50	35
	Nm	31	23	47	34	68	47
7/16-14	ft-lb	32	24	50	35	70	55
	Nm	43	33	68	47	95	75
7/16-20	ft-lb	36	27	55	40	80	60
	Nm	49	37	75	54	108	81
1/2-13	ft-lb	50	35	75	55	110	80
	Nm	68	47	102	75	149	108
1/2-20	ft-lb	55	40	90	65	120	90
	Nm	75	54	122	88	163	122

IMPERIAL BOLT TORQUE CHART							
Size	Torque Type	SAE 2		SAE 5		SAE 8	
		Dry	Lubed	Dry	Lubed	Dry	Lubed
9/16-12	ft-lb	70	55	110	80	150	110
	Nm	95	75	149	108	203	149
9/16-18	ft-lb	80	60	120	90	170	130
	Nm	108	81	163	122	230	176
5/8-11	ft-lb	100	75	150	110	220	170
	Nm	136	102	203	149	298	230
5/8-18	ft-lb	110	85	180	130	240	180
	Nm	149	115	244	176	325	244
3/4-10	ft-lb	175	130	260	200	380	280
	Nm	237	176	353	271	515	380
3/4-16	ft-lb	200	150	300	220	420	320
	Nm	271	203	407	298	569	434
7/8-9	ft-lb	170	125	430	320	600	460
	Nm	230	169	583	434	813	624
7/8-14	ft-lb	180	140	470	360	660	500
	Nm	244	190	637	488	895	678
1-8	ft-lb	250	190	640	480	900	680
	Nm	339	258	868	651	1220	922
1-12	ft-lb	270	210	710	530	1000	740
	Nm	366	285	963	719	1356	1003
1-14	ft-lb	280	210	730	540	1020	760
	Nm	380	285	990	732	1383	1030
1 1/8-7	ft-lb	350	270	800	600	1280	960
	Nm	475	366	1085	813	1735	1302
1 1/8-12	ft-lb	400	300	880	660	1440	1080
	Nm	542	407	1193	895	1952	1464
1 1/4-7	ft-lb	500	380	1120	840	1820	1360
	Nm	678	515	1519	1139	2468	1844
1 1/4-12	ft-lb	550	420	1240	920	2000	1500
	Nm	746	569	1681	1247	2712	2034
1 3/8-6	ft-lb	670	490	1460	1100	2380	1780
	Nm	908	664	1979	1491	3227	2413
1 3/8-12	ft-lb	750	560	1680	1260	2720	2040
	Nm	1017	759	2278	1708	3688	2766
1 1/2-6	ft-lb	870	650	1940	1460	3160	2360
	Nm	1180	881	2630	1979	4284	3200
1 1/2-12	ft-lb	980	730	2200	1640	3560	2660
	Nm	1329	990	2983	2224	4827	3606

Inch-Pound Force = in-lb Foot-Pound Force = ft-lb Newton-Meter = Nm

NOTE: Lubed includes lubricants such as lubrizing, oil, grease or uncured Loctite.

Table 2.6 Torque Specifications for Fasteners (Metric)

METRIC BOLT TORQUE CHART					
Size	Torque Units	8.8		10.9	
		Dry	Lubed	Dry	Lubed
M5 x 0.80	(in-lb)	(54)	(41)	(78)	(59)
	Nm	6.1	4.6	8.8	6.7
M6 x 1.00	(in-lb)	(92)	(69)	(133)	(99)
	Nm	10.4	7.8	15	11.2
M7 x 1.00	(in-lb)	(156)	(116)	(222)	(167)
	Nm	17.6	13.1	25.1	18.9
M8 x 1.25	(in-lb)	(225)	(169)	(333)	(242)
	Nm	25.4	19.1	37.6	27.3
M10 x 1.50	ft-lb	37	28	53	40
	Nm	50	38	72	54
M12 x 1.75	ft-lb	65	49	93	69
	Nm	88	66	126	94
M14 x 2.00	ft-lb	104	78	148	111
	Nm	141	106	201	150
M16 x 2.00	ft-lb	161	121	230	172
	Nm	218	164	312	233
M18 x 2.50	ft-lb	222	167	318	238
	Nm	301	226	431	323
M20 x 2.50	ft-lb	314	235	449	337
	Nm	426	319	609	457
M22 x 2.50	ft-lb	428	321	613	460
	Nm	580	435	831	624
M24 x 3.00	ft-lb	543	407	776	582
	Nm	736	552	1052	789
M27 x 3.00	ft-lb	796	597	1139	854
	Nm	1079	809	1544	1158
M30 x 3.50	ft-lb	1079	809	1543	1158
	Nm	1463	1097	2092	1570
M33 x 3.50	ft-lb	1468	1101	2101	1576
	Nm	1990	1493	2849	2137
M36 x 4.00	ft-lb	1886	1415	2699	2024
	Nm	2557	1918	3659	2744

Inch-Pound Force = in-lb Foot-Pound Force = ft-lb Newton-Meter = Nm

NOTE: Lubed includes lubricants such as lubrizing, oil, grease or uncured Loctite.

Table 2.7 Torque Specifications for Hydraulic Couplings & Hoses

HYDRAULIC COUPLING TORQUE CHART O-Ring Port Connectors				
SAE Size	Steel Ports		Non-ferrous Ports	
	ft-lb	Nm	ft-lb	Nm
4	14-16	20-22	9-10	12-13
6	24-26	33-35	15-16	20-21
8	50-60	68-78	30-36	41-47
10	72-80	98-110	43-48	60-66
12	125-135	170-183	75-81	102-110
16	200-220	270-300	120-132	162-180
20	210-280	285-380	126-168	171-228
24	270-360	370-490	162-216	222-294
32	-	-	-	-

HOSE END TORQUE CHART for JIC									
Size		Steel				Brass			
Dash	Frac.	ft-lb		Nm		ft-lb		Nm	
		Min.	Max.	Min.	Max.	Min.	Max.	Min.	Max.
-4	1/4"	10	11	13	15	5	6	6.75	9
-6	3/8"	17	19	23	26	12	15	17	20
-8	1/2"	34	38	47	52	20	24	27.66	33
-10	5/8"	50	56	69	76	34	40	46.33	55
-12	3/4"	70	78	96	106	53	60	72.33	82
-16	1"	94	104	127	141	74	82	100.5	111
-20	1 1/4"	124	138	169	188	75	83	101.5	113
-24	1 1/2"	156	173	212	235	79	87	107	118
-32	2"	219	243	296	329	158	175	214	237

HOSE END TORQUE CHART for Flat-Face O-Ring Seal (Steel)					
Size		Torque Specification			
Dash	Frac.	ft-lb		Nm	
		Min.	Max.	Min.	Max.
-4	1/4"	10	12	14	16
-6	3/8"	18	20	24	27
-8	1/2"	32	40	43	54
-10	5/8"	46	56	60	75
-12	3/4"	65	80	90	110
-14	1"	65	80	90	110
-16	1 1/4"	92	105	125	240
-20	1 1/2"	125	140	170	190
-24	2"	150	180	200	245

Section 3 - SYSTEM COMPONENT IDENTIFICATION AND SCHEMATICS

Charts

3.1 Electrical Symbol Chart	38
3.2 Hydraulic Symbol Chart.....	39
3.3 Wire Number and Color Code.....	40
3.4 AC Cord Color Code.....	41

Parts List









































3.5 Hydraulic Schematic Parts List.....	42
3.5 Hydraulic Schematic Parts List (Continued).....	43
3.6 Electrical Components Parts List.....	44
3.6a Electrical Component Parts List (Continued)	45
3.6b Electrical Component Parts List (Continued).....	46
3.7a Hydraulic Manifold and Port Identifications.....	47
3.7b Hydraulic Manifold and Port Identifications.....	48

Diagrams and Schematics



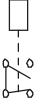
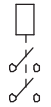

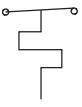
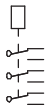













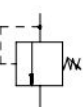
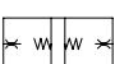







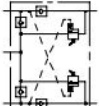



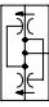



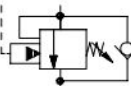

3.8a Platform Control Console Diagram.....	49
3.8b Platform Control Console Diagram - Long Cable Option	50
3.9a Powerdeck Platform Modification Diagram	51
3.9b Powerdeck Platform Modification Diagram.....	52
3.10 Powered Extension Platform Control Console and Harness	53
3.11a Base Control Console Diagram (Including EE-Rated)	54
3.11b Base Control Console Diagram (Non EE-Rated Only).....	55
3.12a Scissor Arm Control Cable Diagram	56
3.12b Scissor Arm Control Cable Diagram (EE-Rated)	57
3.13 Limit Switch Assembly Wire Diagrams	58
3.14 Harness Wire Diagrams.....	59
3.15 Telematics Harness - ZTR	60
3.16a Hydraulic Schematic (Models 322x).....	62
3.16b Hydraulic Schematic (Models 322x)	63
3.17a Hydraulic Schematic (Models 46xx).....	64
3.17b Hydraulic Schematic (Models 46xx).....	65
3.17c Hydraulic Schematic (Models 46xx).....	66
3.18 Main Manifold Harness	67
3.19 Main Manifold Harness (EE-Rated)	68
3.20 Elevate Telematics Harness	69
3.21a Electrical Panel Diagram.....	70
3.21b Electrical Panel Diagram.....	71
3.22a Electrical Panel Diagram with Power Deck.....	72
3.22b Electrical Panel Diagram with Power Deck	73
3.23a Electrical Panel Diagram (EE Rated)	74
3.23b Electrical Panel Diagram (EE Rated).....	75
3.23c Electrical Panel Diagram (EE Rated)	76
3.24a Electrical Panel Diagram (EE Rated) with Power Deck.....	77
3.24b Electrical Panel Diagram (EE Rated) with Power Deck.....	78
3.24c Electrical Panel Diagram (EE Rated) with Power Deck.....	79
3.25a Electrical Panel Diagram - Inverter	80
3.25b Electrical Panel Diagram - Inverter	81

3.26a	Electrical Panel Diagram with Power Deck - Inverter	82
3.26b	Electrical Panel Diagram with Power Deck - Inverter	83
3.27	Horn/Tilt Switch/Flashing Light Diagram	84
3.28a	Electrical Schematic (ANSI/CSA except EE rated - Equipped with no options)	85
3.28b	Electrical Schematic (ANSI/CSA except EE rated - Equipped with no options)	86
3.29a	Electrical Schematic (EE Rated - Equipped with no options)	87
3.29b	Electrical Schematic (EE Rated - Equipped with no options)	88
3.29c	Electrical Schematic (EE Rated - Equipped with no options)	89
3.30a	Electrical Schematic (All Models - Equipped with all options)	90
3.30b	Electrical Schematic (All Models - Equipped with all options)	91
3.30c	Electrical Schematic (All Models - Equipped with all options)	92
3.30d	Electrical Schematic (All Models - Equipped with all options) - EE-Rated	93

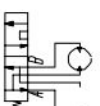
3.1 Electrical Symbol Chart

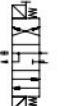
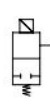
 CIRCUIITS CROSSING NO CONNECTION	 HOURMETER	 KEY SWITCH	 LIMIT SWITCH N.O.
 CIRCUIITS CONNECTED	 LIGHT	 FOOT SWITCH	 LIMIT SWITCH N.O. HELD CLOSED
 BATTERY	 HYDRAULIC VALVE COIL	 TOGGLE SWITCH	 LIMIT SWITCH N.C.
 GROUND	 PROPORTIONAL HYDRAULIC VALVE COIL	 PUSH BUTTON	 LIMIT SWITCH N.C. HELD OPEN
 FUSE	 ELECTRIC MOTOR	 ROTARY SWITCH	 SILICON CONTROLLED RECTIFIER
 CIRCUIT BREAKER	 HORN	 LIMIT SWITCH	 PROXIMITY SWITCH
 VOLT METER	 EMERGENCY STOP BUTTON	 CAM OPERATED LIMIT SWITCH	 PNP TRANSISTOR
 CAPACITOR	 RESISTOR	 TILT SWITCH	 NPN TRANSISTOR
 POTENTIOMETER	 LEVEL SENSOR	 SINGLE POLE SINGLE THROW RELAY	 PRESSURE/ VACUUM SWITCH
 SINGLE POLE DOUBLE THROW RELAY	 DOUBLE POLE SINGLE THROW RELAY	 DOUBLE POLE DOUBLE THROW RELAY	 TEMPERATURE SWITCH
 TRIPLE POLE DOUBLE THROW RELAY	 DIODE	 RHEOSTAT	

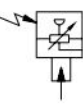
3.2 Hydraulic Symbol Chart

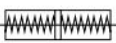
	LINE CROSSING		VARIABLE DISPLACEMENT PUMP		SHUTTLE VALVE		VELOCITY FUSE
	LINE JOINED		HAND PUMP		ACCUMULATOR, GAS CHARGED		SINGLE ACTING CYLINDER
	HYDRAULIC TANK		RELIEF VALVE		CUSHION CYLINDER		DOUBLE ACTING CYLINDER
	HYDRAULIC FILTER WITH BYPASS		PRESSURE REDUCING VALVE		PRESSURE SWITCH		DOUBLE ACTING DOUBLE RODDED CYLINDER
	ELECTRIC MOTOR		FIXED ORIFICE		MOTION CONTROL VALVE		SPRING APPLIED HYDRAULIC RELEASED BRAKE
	ENGINE		ADJUSTABLE FLOW CONTROL		FLOW DIVIDER COMBINER		BRAKE CYLINDER
	FIXED DISPLACEMENT PUMP		CHECK VALVE		COUNTER BALANCE VALVE		ROTARY ACTUATOR
	VARIABLE DISPLACEMENT HYDRAULIC MOTOR		OIL COOLER		VALVE COIL		BI DIRECTIONAL HYDRAULIC MOTOR
	SERIES PARALLEL HYDRAULIC MOTOR		TWO POSITION TWO WAY NORMALLY CLOSED VALVE		TWO POSITION THREE WAY VALVE		THREE POSITION FOUR WAY CLOSED CENTER OPEN PORT
	TWO POSITION TWO WAY NORMALLY OPEN VALVE		TWO POSITION THREE WAY VALVE		THREE POSITION FOUR WAY CLOSED CENTER CLOSED PORT		
	PRESSURE TRANSDUCER		MAIN LINES Solid		PILOT LINES Dashed		
	SERVO						

3.3 Wire Number and Color Code

WIRE NO.	WIRE COLOR	WIRE NO.	WIRE COLOR	WIRE NO.	WIRE COLOR	WIRE NO.	WIRE COLOR	WIRE NO.	WIRE COLOR
00	WHT	20	ORG/BLU	44	YEL/WHT	67	ORG/BRN	92	GRN SHLD
000	WHT	21	WHT/RED	45	YEL/ORG	68	GREY	93	BLK SHLD
B1	BLU/PINK	23	BLK/WHT	46	RED/BLK	69	WHT/GRN	95	YEL/GREY
01	PUR/BLK	24	BLU/BLK	47	PUR/ORG	70	ORG/PINK	96	WHT/GREY
02	WHT	25	BRN/BLK	48	YEL/GREY	71	RED/ORG	97	ORG/GREY
03	GRN/PUR	26	BLU/YEL	49	GRN/RED	72	RED/BRN	98	RED SHLD
04	RED/YEL	27	RED/BLK/WHT	50	BRN	73	RED/PINK	98A	BLK SHLD
05	PUR	28	GRN	51	BLK/GRN	74	GRN/ GREY	99	BLK/GREY
06		29	GREY/ORG	52	GRN/BLU	75	GREY/PUR	103	BLK/PUR
07	RED	30	RED/GRN	53	BRN/RED	76	BRN/BLU	104	GRN/ORG
08	PUR/WHT	31	RED/WHT	54	PUR/RED	77	BRN/GREY	105	GRN/BRN
09	YEL	32	GRN/BLK	55	YEL/PUR	78	RED/BLU	106	GRN/PINK
10	BLU/WHT	33	GRN/WHT	56	YEL/BLK	79	BRN/PUR	107	BLK/BLU
11	WHT/ORG	34	ORG/BLK	57	BRN/GRN	80	GREY/ WHT	108	YEL/BRN
12	RED/YEL/ BLK	35	ORG/WHT	58	WHT/PUR	81	GREY/BLK	109	GRN/YEL
13	ORG	36	RED/PUR	59	YEL/BLU	82	BRN/WHT	110A	BLU
14	BLK	37	WHT/RED/ BLK	60	WHT/BLU	83	BLU/GREY	110B	BRN
15	BLU	38	ORG/RED	61	GREY/BRN	84	WHT/BLK/ PUR	111	GREY/GRN
16	WHT/BLK	39	BLK/RED	62	GREY/RED	85	GREY/BLU	112	BLU/ORG
17	BLU/GRN	40	BLU/RED	63	GREY/YEL	86/87	PUR/BLU	113	BLU/BRN
18	GRN/BLU	41	BLU/PUR	64	WHT/BRN	88	BLK/ORG	114	YEL/RED
19	ORG/GRN	42	PINK	65	YEL/PINK	90	RED/GREY	115	WHT/PUR
22	PUR/GRN	43	WHT/YEL	66	ORG/YEL	91	RED SHLD	118	PUR/PINK

This table is to be used as a wire number/color reference for all electrical drawings and schematics. All wire numbers will retain their original color coding, for example if wire 7 is red, wire 7A, 7B, and 7C will also be red.

3.4 AC Cord Color Code

AH

Standard Definition	NEC Colours	IEC Colours
Protective Ground/Protective Earth	Green	Green-Yellow
Neutral	White	Blue
Line, Single Phase	Black	Black/Brown/Grey

Note: Standard colours referenced from IEC 60445:2010, Annex A:Table A.1

AK

3.5 Hydraulic Schematic Parts List

Index No.	Skyjack Part No.	Qty.	Description
2H-13	103655	1	VALVE, Control (Lowering)
2H-13-1	107269	1	VALVE, Control (Holding)
2H-13-2	107269	1	VALVE, Control (Holding)
2H-18A	104132	1	VALVE, Control (Differential)
2H-59B	132749	1	VALVE, Control (Proportional)
3H-14	106273	1	VALVE, Control (Lift)
3H-17A	103623	1	VALVE, Control (Brake)
3H-18A-1	103623	1	VALVE, Control (Speed A)
3H-18A-2	103623	1	VALVE, Control (Speed B)
4H-15	153334	1	VALVE, Control (Reverse drive) (Hytos) (includes 4H-16)
4H-16	-	1	VALVE, Control (Forward drive) (Hytos)
4H-23	153334	1	VALVE, Control (Right steer) (Hytos) (includes 4H-24)
4H-24	-	1	VALVE, Control (Left steer) (Hytos)
4H-26	113953	1	VALVE, Powered platform extend (includes 4H-27) (Models 3220/4626)
4H-27	-	1	VALVE, Powered platform retract (Models 3220/4626)
C1	124291	1	CYLINDER (Cushion)
C2	120989	1	CYLINDER (Lift) (Model 3220)
	120989	2	CYLINDER (Lift) (Models 3226/4626/4632)
C3	120236	1	CYLINDER (Steer)
C4	120220	2	CYLINDER (Brake) (Models 322x)
C5	127100	1	CYLINDER (Powered extension platform) (Model 3220)
	127100	2	CYLINDER (Powered extension platform) (Model 4626)
CB1	147889	1	VALVE, Counterbalance
CRV1	115299	1	VALVE, Cross-Over Relief (Option)
F1	109568	1	FILTER ASSEMBLY, Return
FD1	103354	1	VALVE, Flow divider/combiner
M1	103129	1	MOTOR, Hydraulic Wheel (Left hand) (Models 322x)
M2	103129	1	MOTOR, Hydraulic Wheel (Right hand) (Models 322x)
M3	134573	1	MOTOR, Hydraulic Wheel (Left hand) (Models 46xx)
M4	134573	1	MOTOR, Hydraulic Wheel (Right hand) (Models 46xx)
MB1	107354	1	BLOCK, Manifold (Main)
MB2	107493	1	BLOCK, Manifold (Emergency lowering)
MB3	130481	1	BLOCK, Manifold (Holding valve) (Model 3220)
	111320	1	BLOCK, Manifold (Upper holding valve) (Models xx26/4632)
	111316	1	BLOCK, Manifold (Lower holding valve) (Models xx26/4632)
MB4	108195	1	BLOCK, Manifold (Rear drive)
MB5	160454	1	BLOCK, Manifold (Powered extension platform)
MB7	146563	1	MANIFOLD BLOCK (Brake release) (Models 46xx)
MB9	132748	1	MANIFOLD BLOCK (Proportional control)
O2	105530	1	ORIFICE (0.081" diameter) (Lowering) (Model 4632)
O3	105811	1	ORIFICE (0.040" diameter) (Steer)
O4	105281	1	ORIFICE (0.067" diameter) (Emergency lowering) (Model 3220)
	105281	2	ORIFICE (0.067" diameter) (Emergency lowering) (Models 3226/4626/4632)
O6	104434	1	ORIFICE (0.040" diameter) (Differential)
O7	104434	1	ORIFICE (0.040" diameter) (Brake) (Models 322x)
	137127	1	ORIFICE (0.020" diameter) (Brake) (Models 46xx)

Parts list continued on the following page.

3.5 Hydraulic Schematic Parts List (Continued)

Index No.	Skyjack Part No.	Qty.	Description
Parts list continued from the previous page.			
P1	106587	1	PUMP, Hydraulic (Models 4626/4632, except EE rated)
	129961	1	PUMP, Hydraulic (EE rated)
	129965	1	PUMP, Hydraulic (EE rated)
	310567	1	PUMP, Hydraulic (Standard)
P2	146560	1	PUMP, Handle (Brake release) (Models 46xx)
PS1	102863	1	SWITCH, Pressure (Option)
	113799	1	• BLOCK, Manifold
R1	104534	1	VALVE, Relief (System)
R2	104534	1	VALVE, Relief (Lift)
R3	106557	2	VALVE, Relief (Holding valve) (Models 3226/4626/4632)
V1	107271	1	VALVE (Emergency lowering)
V2	103136	1	VALVE (Free-wheeling)
V3	146562	1	VALVE (Auto reset - brake release) (Models 46xx)

AH

3.6 Electrical Components Parts List

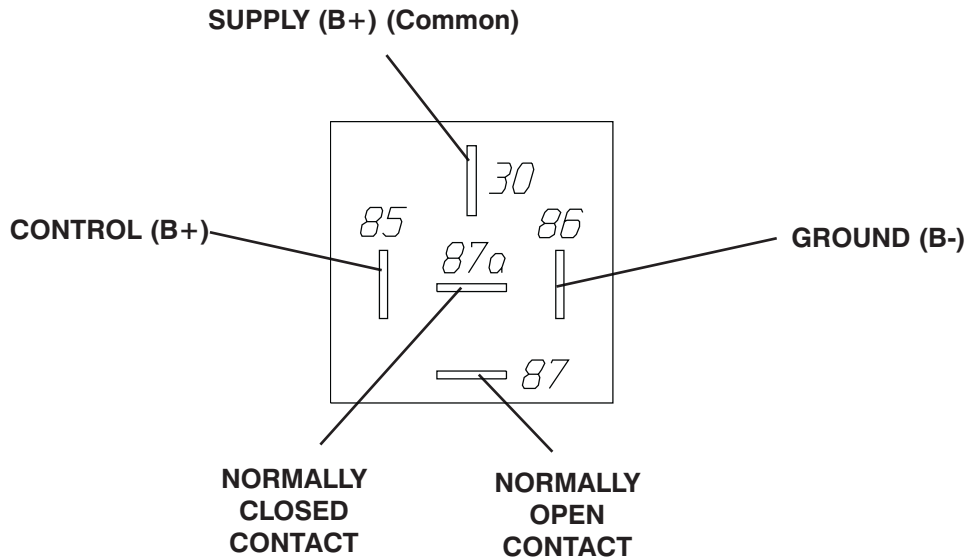

Index No.	Skyjack Part No.	Qty.	Description
17CR	108589	1	RELAY, 24 Volt (Transfer)
21CCR	108589	1	RELAY, 24 Volt (Proportional)
28CR	108589	1	RELAY, 24 Volt (Tilt switch)
9ACR-1	108589	1	RELAY, 24 Volt (Powerdeck #1)
9ACR-2	108589	1	RELAY, 24 Volt (Powerdeck #2)
2H-13	103605	1	COIL, 24 Volt (Lowering valve)
2H-13-1	104493	1	COIL, 24 Volt (Holding valve)
2H-13-2	104493	1	COIL, 24 Volt (Holding valve)
2H-18A	103605	1	COIL, 24 Volt (Differential valve)
2H-59	115370	1	COIL, 24 Volt (Proportional valve)
3H-14A	105610	1	COIL, 24 Volt (Lift valve)
3H-17A	103605	1	COIL, 24 Volt (Brake valve)
3H-18A-1	103605	1	COIL, 24 Volt (Speed A)
3H-18A-2	103605	1	COIL, 24 Volt (Speed B)
4H-15	153335	1	COIL, 24 Volt (Reverse drive spool valve) (Hytos)
4H-16	153335	1	COIL, 24 Volt (Forward drive spool valve) (Hytos)
4H-23	153335	1	COIL, 24 Volt (Right steer spool valve) (Hytos)
4H-24	153335	1	COIL, 24 Volt (Left steer spool valve) (Hytos)
4H-26	103605	1	COIL, 24 Volt (Power extension platform extend) (option)
4H-27	103605	1	COIL, 24 Volt (Power extension platform retract) (option)
AT1	130440	1	TRANSDUCER, Angle
B1-B4	103480	4	BATTERY, 6 Volt (U2200)
B1-B4	106552	4	BATTERY, 6 Volt (U2500)

Parts list continued on the following page.

3.6a Electrical Component Parts List (Continued)

AJ

Index No.	Skyjack Part No.	Qty.	Description
Parts list continued from the previous page.			
BC	128537	1	CHARGER, 24VDC Battery (superior universal)
BCI	122093	1	BATTERY CHARGE INDICATOR
BP-29	103057	1	BEEPER, 24 VDC
C1	146475	1	CONTACTOR, Motor (24 Volt)
CAP1	110699	1	CAPACITOR (.47UF 50 Volts)
CB1	117325	2	BREAKER, Circuit (15 Amp)
CB2	117325	2	BREAKER, Circuit (15 Amp)
D02-X	129258	AR	DIODE
D19A	-		ALARM OPTION
DA1	119758	1	DIODE PACK
DA2	119520	1	DIODE ASSEMBLY
DA3	119624	1	DIODE ASSEMBLY
DCM1	147664	1	MOTOR (24 VDC)
	123477	1	MOTOR (24 VDC) (EE rated)
DXX	102921	AR	DIODE
F1	310517	1	FUSE (300 Amp in-line fuse)
FL-22	121477	1	FLASHING LIGHT, 24VDC (Option)
FL-29	103743	1	FLASHER (Option)
H1	146649	1	HORN, Operator (Low tone)
LED-1	147061	1	POWER INDICATOR LIGHT (Platform control console)
LED-2	147061	1	POWER INDICATOR LIGHT (Base control console)
LS1A	121975	1	LIMIT SWITCH (High speed)
	199485	1	LIMIT SWITCH (High speed) (For model 3220 with serial number 60007078 & Above) (For model 3226 with serial number 27032455 & Above) (For model 46xx with serial number 70032134 & Above)
LS1B	121975	1	LIMIT SWITCH (High speed)
LS3	122014	1	LIMIT SWITCH (End of stroke - option)
LS4	125887	1	LIMIT SWITCH, Pothole protection (Battery tray)
LS4	126051	1	LIMIT SWITCH, Pothole protection (Battery tray) (EE rated)
LS5	125885	1	LIMIT SWITCH, Pothole protection (Hydraulic tray)
LS5	126060	1	LIMIT SWITCH, Pothole protection (Hydraulic tray) (EE rated)
LS6	121975	1	LIMIT SWITCH (Drive override) (For model 3220 with serial number 60007078 & Above) (For model 3226 with serial number 27032455 & Above) (For model 46xx with serial number 70032134 & Above)
	199485	1	LIMIT SWITCH (Drive override) (For model 3220 with serial number 60007078 & Above) (For model 3226 with serial number 27032455 & Above) (For model 46xx with serial number 70032134 & Above)
RST1	119629	1	RESISTOR (2.7K ohm)
RST2	168596	1	RESISTOR (25 ohm)
RST3	116505	1	RESISTOR, Low voltage protection (56 Ohms)
Parts list continued on the following page.			

AI

3.6b Electrical Component Parts List (Continued)

Index No.	Skyjack Part No.	Qty.	Description
Parts list continued from the previous page.			
S1	119725	1	SWITCH, Main power disconnect
S2	147054	2	N.O. CONTACT (Raise/Lower)
S3	116382	1	SWITCH, Toggle (Lift/Off/Drive)
S4	147053	2	N.C. CONTACT (Emergency stop) (Platform control console)
S7	123994	1	CONTROLLER ASSEMBLY, Proportional
S7-1	122869	1	SWITCH (Neutral)
S7-2	122877	1	SWITCH (Right steer)
S7-3	122877	1	SWITCH (Left steer)
S7-6	122872	1	SWITCH, Pushbutton (Enable)
S8	147054	1	N.O. CONTACT (Horn)
S10	147053	2	N.C. CONTACT (Off/Platform)
	147054	1	N.O. CONTACT (Base)
S11	102853	1	SWITCH (Powered extension platform extend/retract)
S12	102853	1	SWITCH (Powered extension platform enable)
S27	115574	1	SWITCH, Toggle (Torque)
S28	147053	1	N.C. CONTACT (Emergency stop) (Base control console)
TS1	146658	1	TILT SWITCH (Models 322x)
	146661	1	TILT SWITCH (Models 46xx)
TT	195940	1	HOURMETER, Digital
TIMER	137417	1	TIMER, Relay - Delay-On-Release

3.7a Hydraulic Manifold and Port Identifications

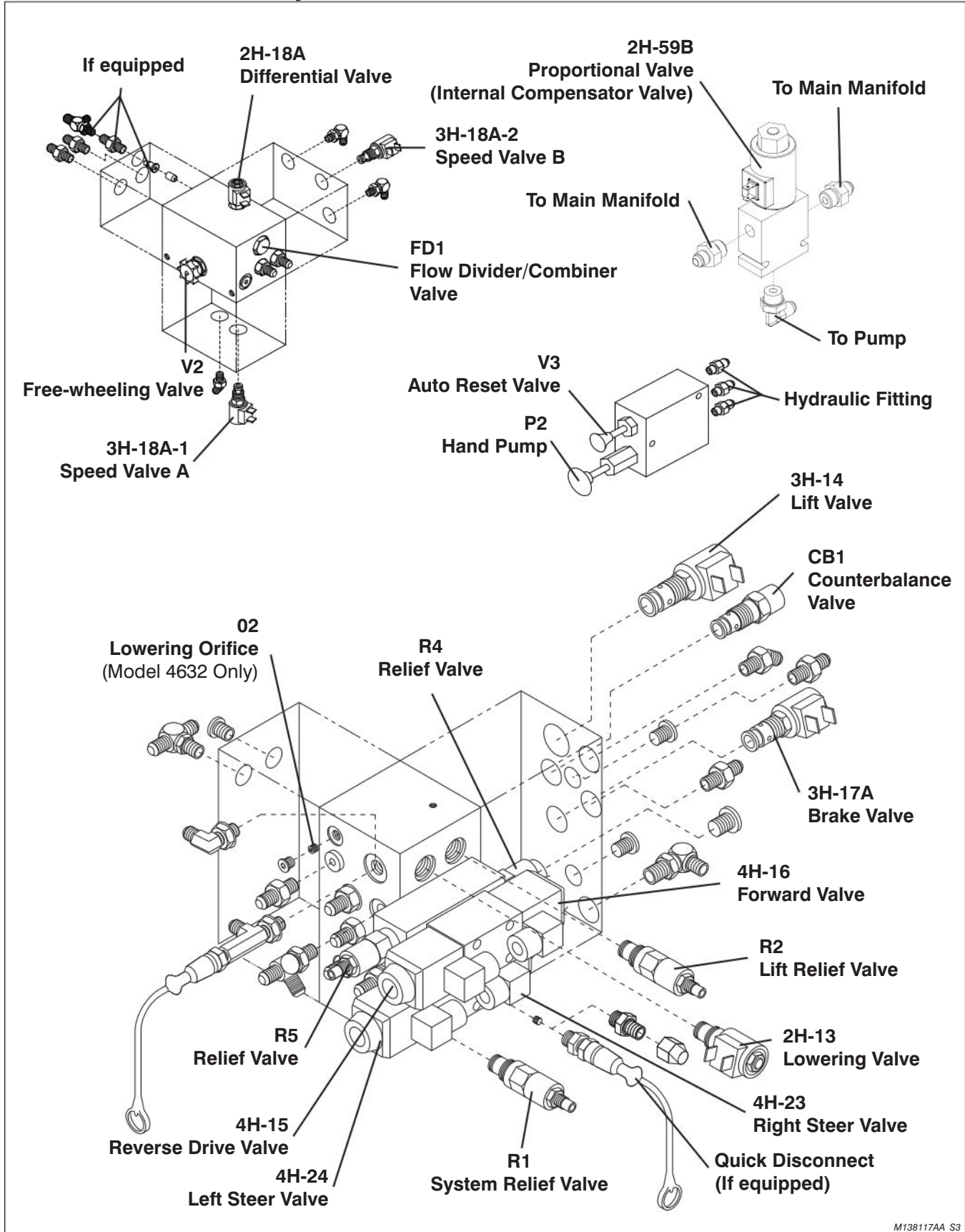

M138117AA_S3

AE

3.7b Hydraulic Manifold and Port Identifications

Serial Breakdown Reference Chart	
Model	Serial Number
SJ3 3220	60003929 & above
SJ3 4620/26	70015230 & above

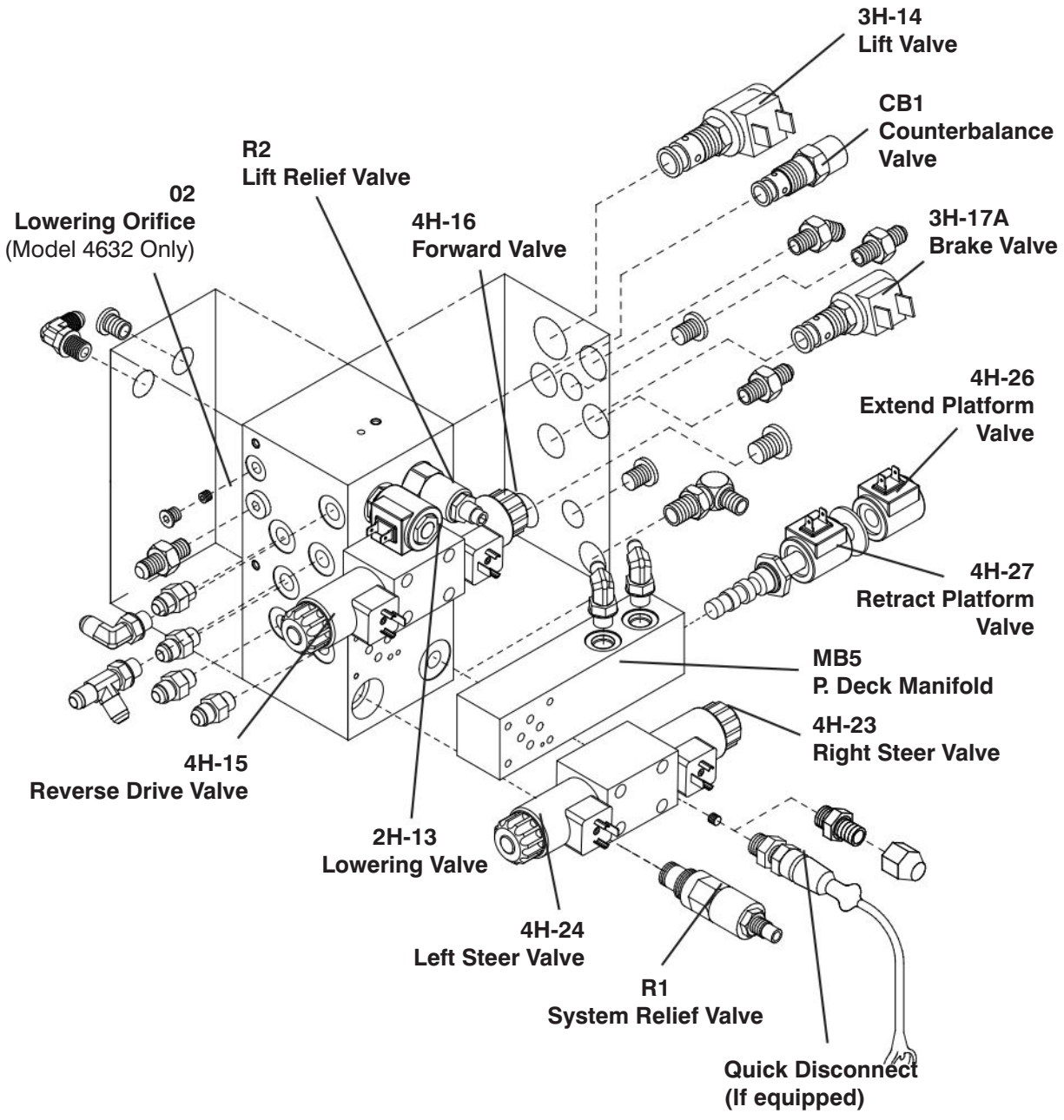

M138117AA_S3

3.8a Platform Control Console Diagram

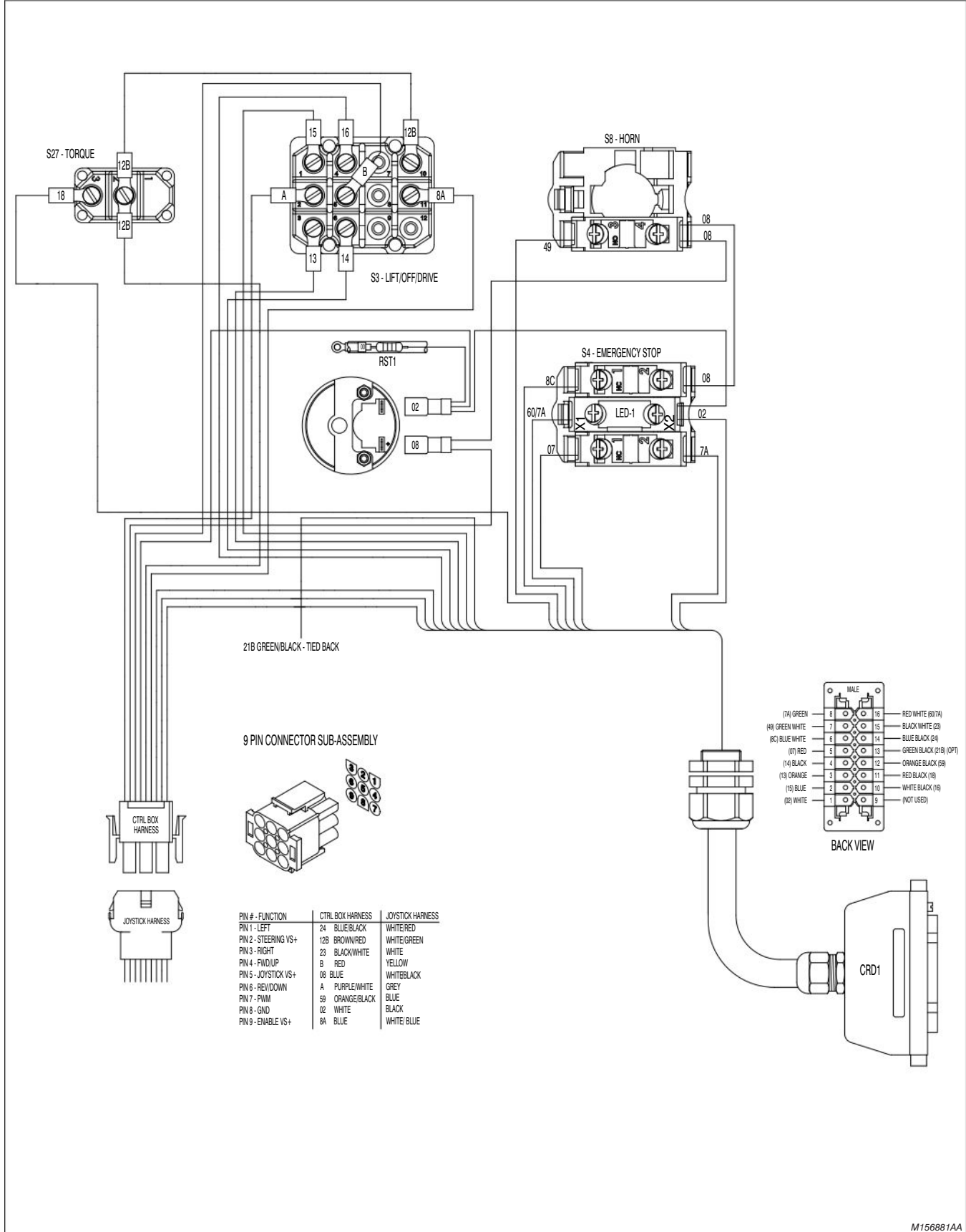

M156881AA

3.8b Platform Control Console Diagram - Long Cable Option

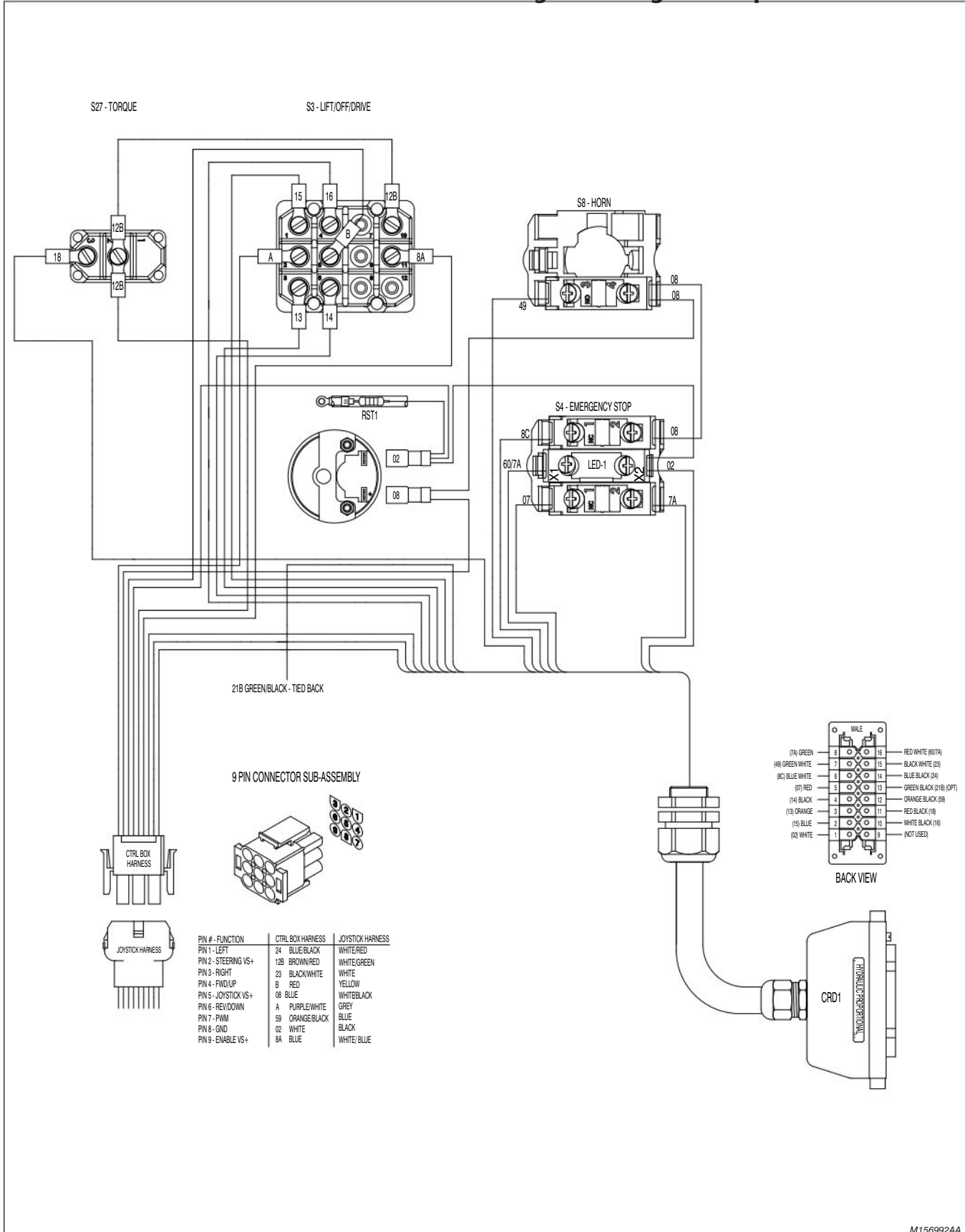

M156992AA

3.9a Powerdeck Platform Modification Diagram

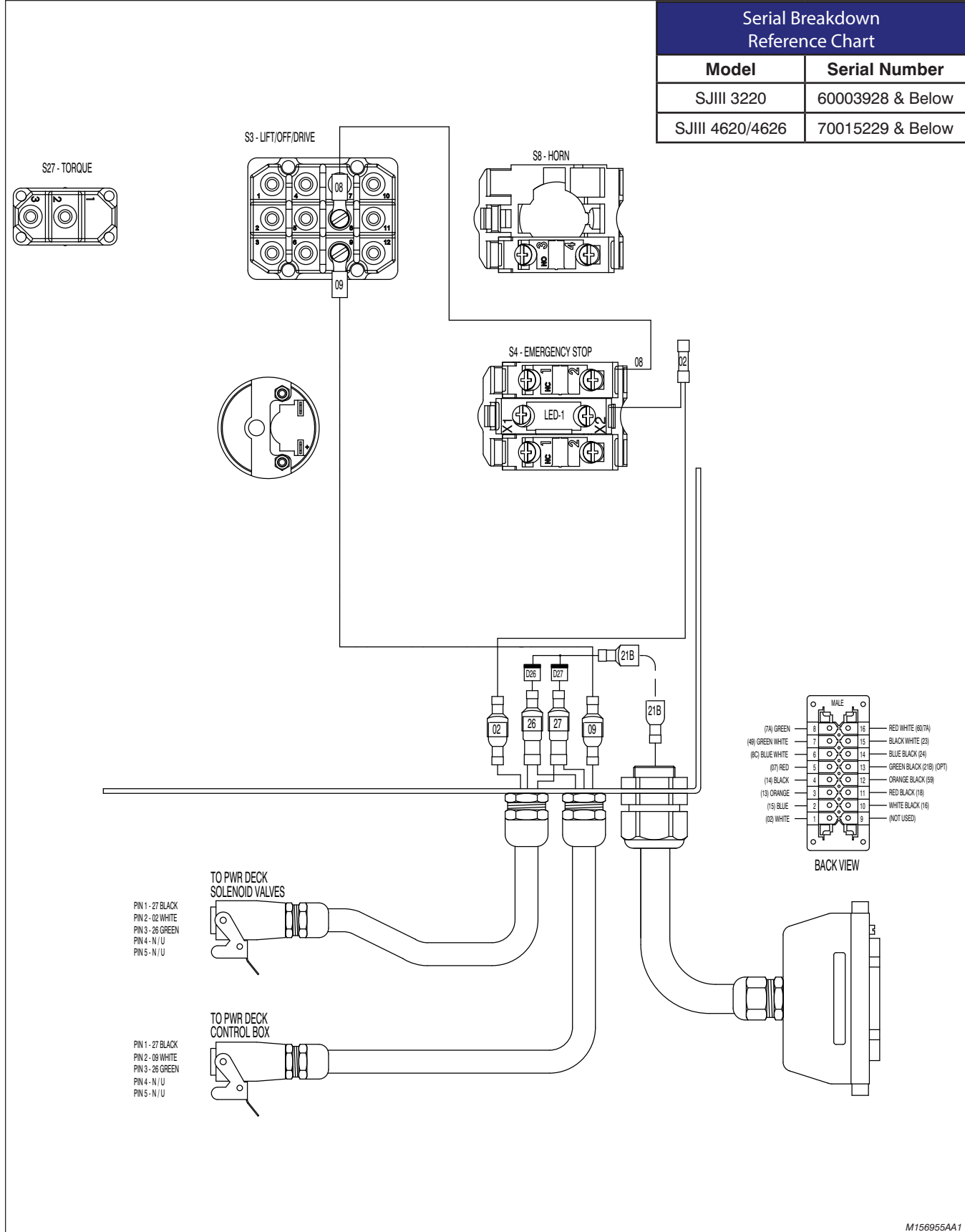

M156955AA1

3.9b Powerdeck Platform Modification Diagram

Serial Breakdown Reference Chart	
Model	Serial Number
SJIII 3220	60003929 & Above
SJIII 4620/4626	70015230 & Above

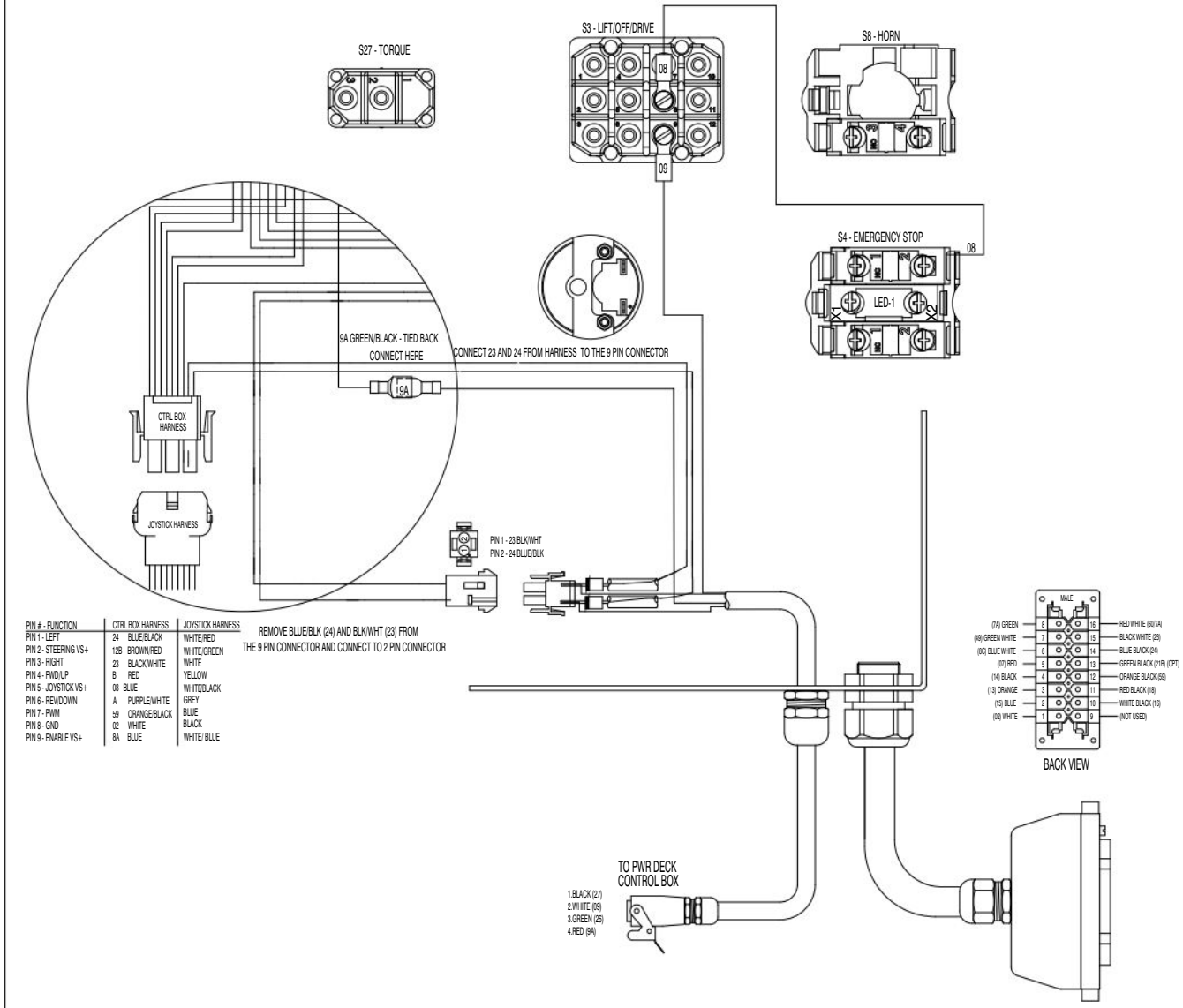

PIN # - FUNCTION	CTRL BOX HARNESS	JOYSTICK HARNESS
PIN 1 - LEFT	24 BLUE/BLACK	WHITE/RED
PIN 2 - STEERING VS+	12B BROWN/RED	WHITE/GREEN
PIN 3 - RIGHT	23 BLACK/WHITE	WHITE
PIN 4 - FWD/LP	9 RED	YELLOW
PIN 5 - JOYSTICK VS+	08 BLUE	WHITE/BLACK
PIN 6 - REV/DOWN	A PURPLE/WHITE	GREY
PIN 7 - PWM	59 ORANGE/BLACK	BLUE
PIN 8 - GND	02 WHITE	BLACK
PIN 9 - ENABLE VS+	8A BLUE	WHITE/BLUE

REMOVE BLUE/BLK (24) AND BLK/WHT (23) FROM THE 9 PIN CONNECTOR AND CONNECT TO 2 PIN CONNECTOR

M164704AC_1

3.10 Powered Extension Platform Control Console and Harness

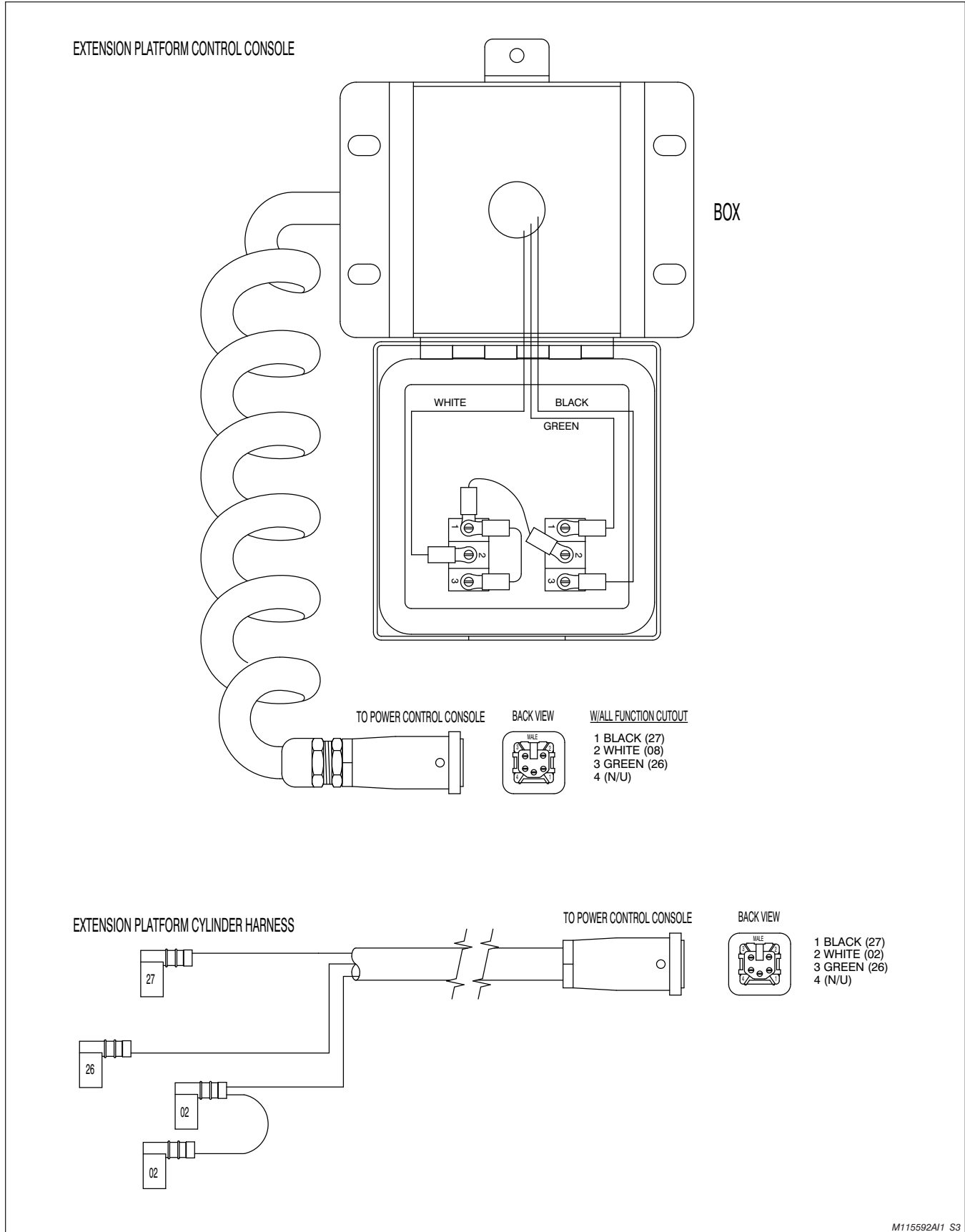

M115592A11_S3

AI 3.11a Base Control Console Diagram (Including EE-Rated)

Serial Breakdown Reference Chart	
Model	Serial Number
SJIII 3220	60006146 & Below
SJIII 3226	27028841 & Below
SJIII 46xx	70028673 & Below
SJIII 3220 EE-Rated	60002259 & Above
SJIII 3226 EE-Rated	27006432 & Above
SJIII 46xx EE-Rated	70007139 & Above

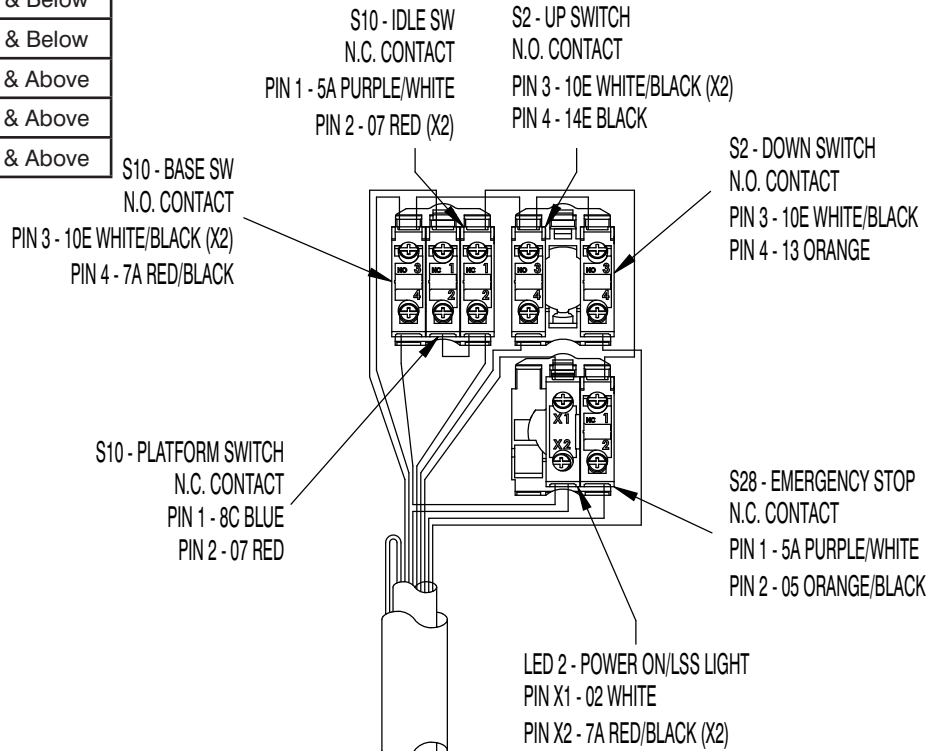

TO ELECTRIC PANEL
 PIN 1 - 07 (RED)
 PIN 2 - 05 (ORANGE/BLACK)
 PIN 3 - 13 (ORANGE)
 PIN 4 - 14E (BLACK)
 PIN 5 - 10E (WHITE/BLACK) (CE)
 PIN 6 - 8C (BLUE)
 PIN 7 - 7A (RED/BLACK)
 PIN 8 - 02 (WHITE)

BACK VIEW

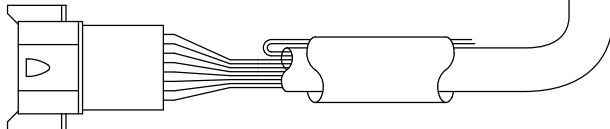
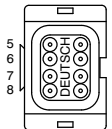

M149553AA_S3

3.11b Base Control Console Diagram (Non EE-Rated Only)

AI

Serial Breakdown Reference Chart	
Model	Serial Number
SJIII 3220	60006147 & Above
SJIII 3226	27028842 & Above
SJIII 46xx	70028674 & Above

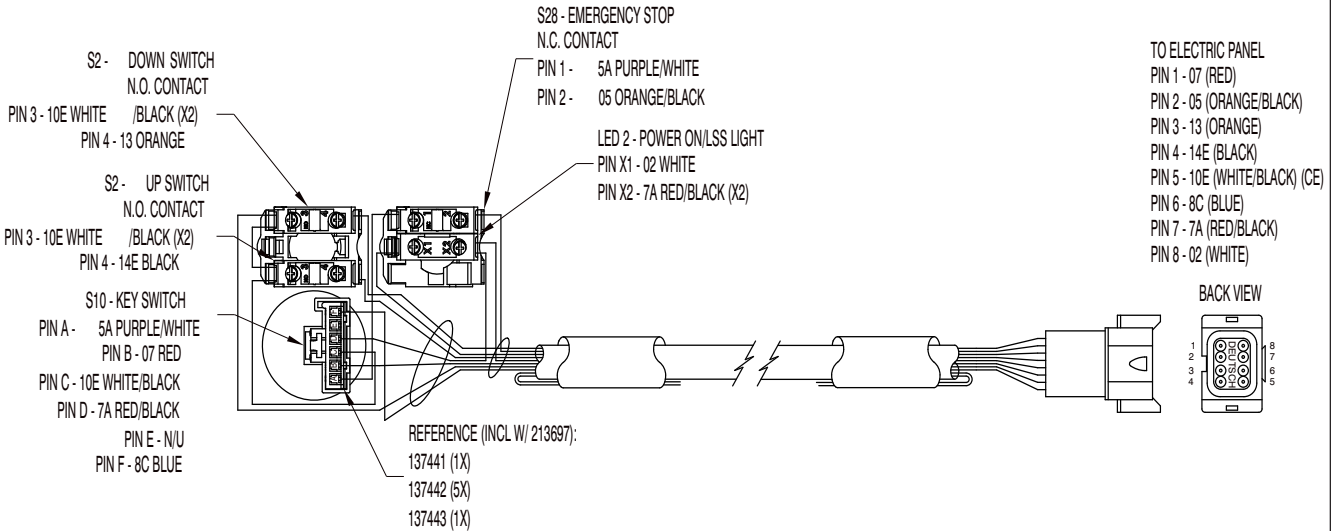

M195843AB

3.12a Scissor Arm Control Cable Diagram

CONTROL CABLE OPTIONS		
WIRE COLOUR	EUROPE WIRE NUMBER	N.A WIRE NUMBER
GREEN/BLACK	21B	21B
RED/WHITE	60	7A

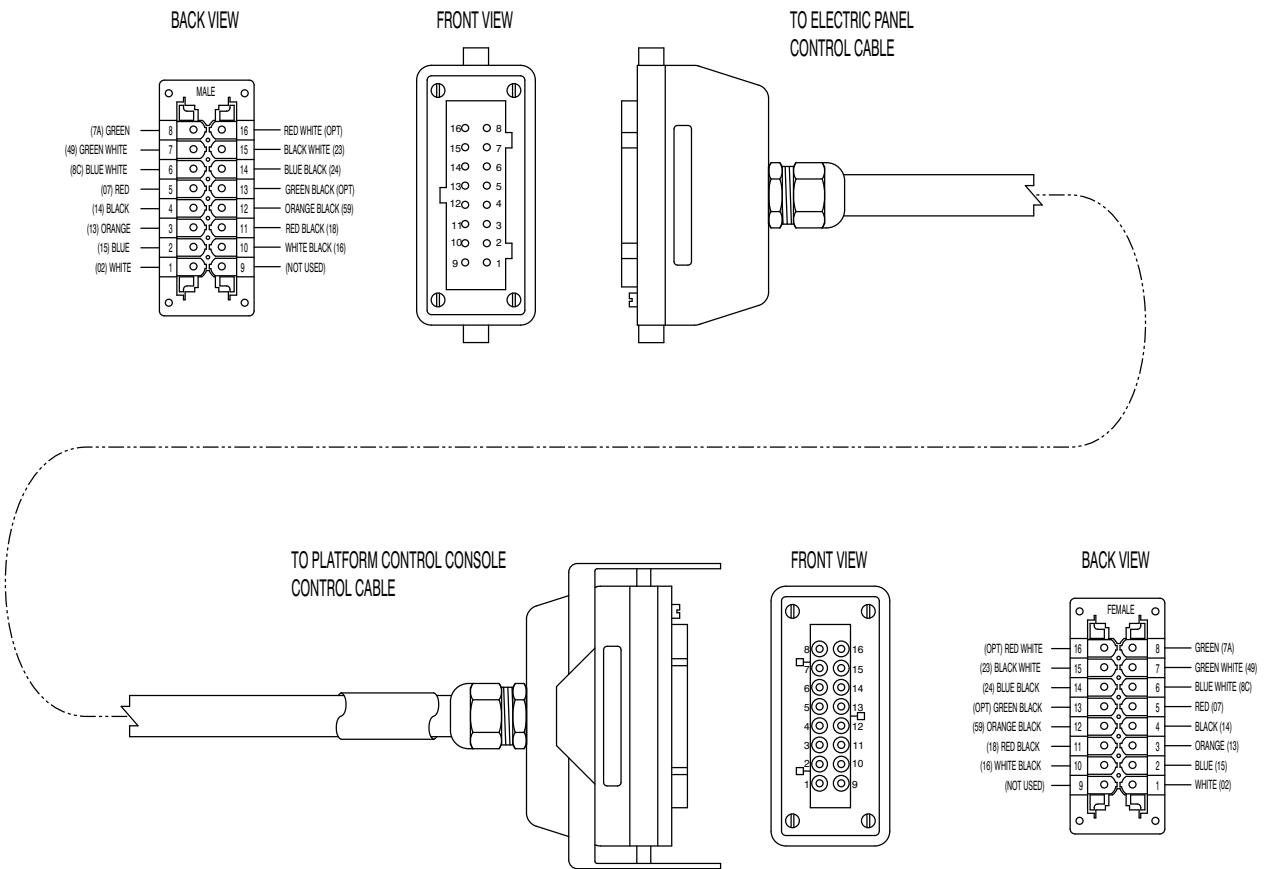

M146650AB_S3

3.12b Scissor Arm Control Cable Diagram (EE-Rated)

AF

CONTROL CABLE OPTIONS		
WIRE COLOUR	EUROPE WIRE NUMBER	N.A. WIRE NUMBER
GREEN/BLACK	21B	9A
RED/WHITE	60	7A

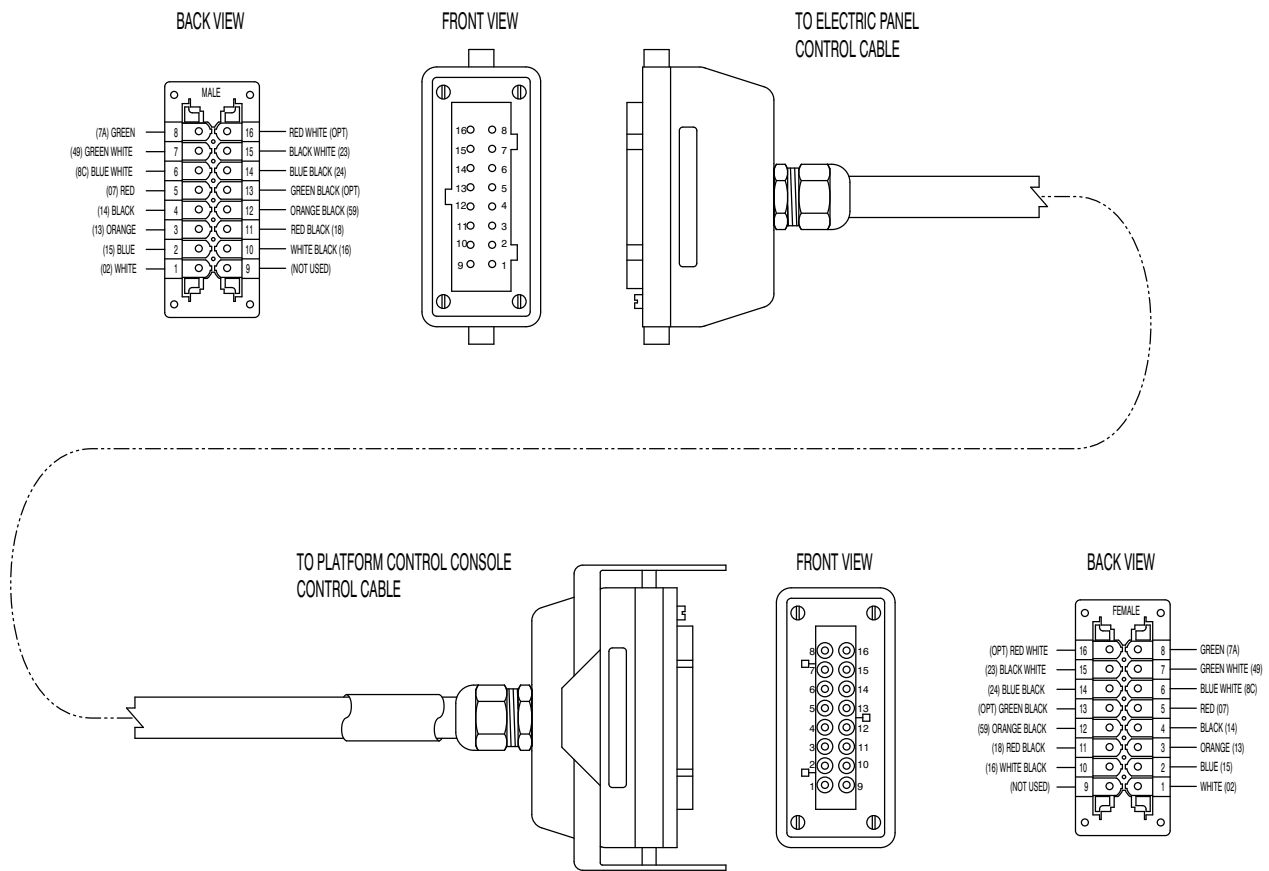

M159307AB

AF

3.13 Limit Switch Assembly Wire Diagrams

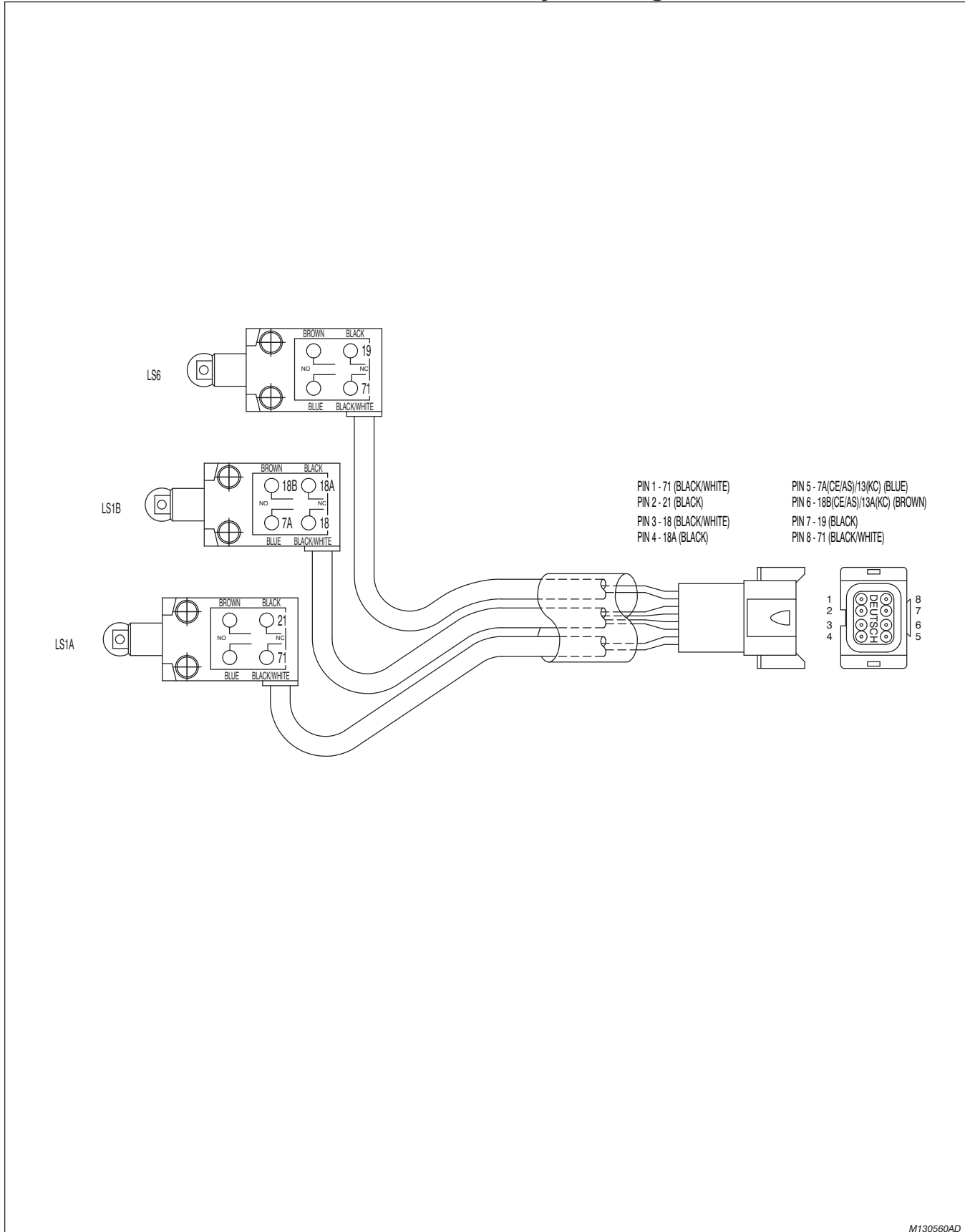

M130560AD

3.14 Harness Wire Diagrams

HORN/FLASHING LIGHT HARNESS

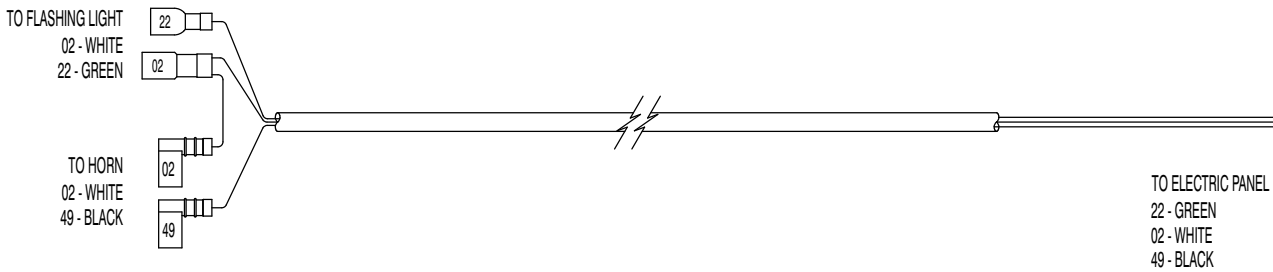

TILT SWITCH HARNESS

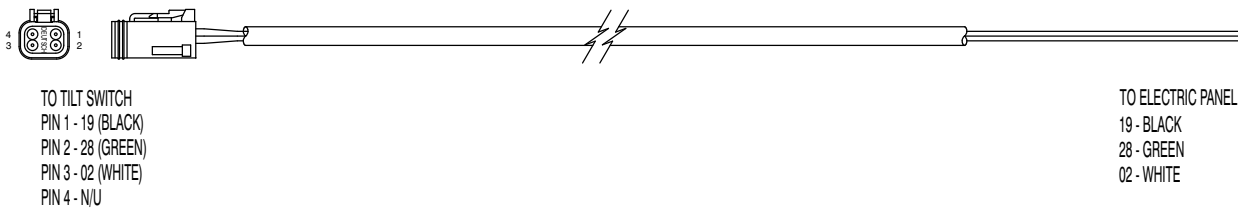

CHARGER CUTOUT HARNESS

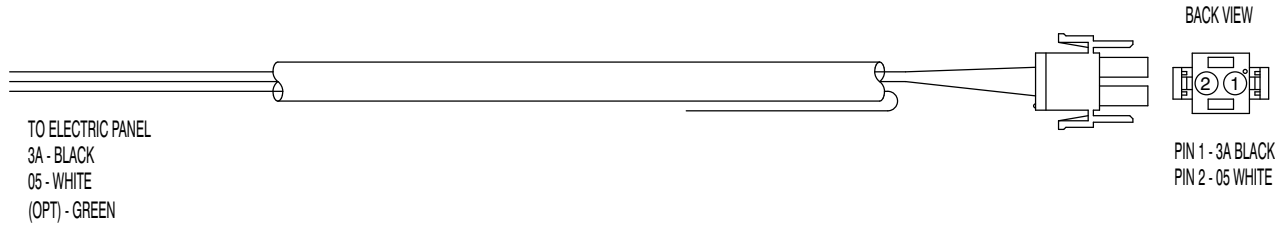

CHARGER CUTOUT HARNESS - EE RATED MODELS



HOLDING VALVE HARNESS - MODEL XX20

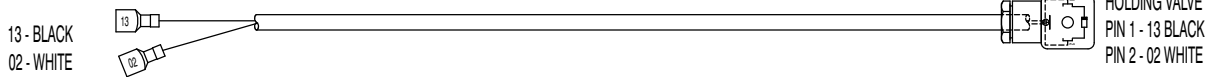

HOLDING VALVE HARNESS - MODEL XX26 / XX32

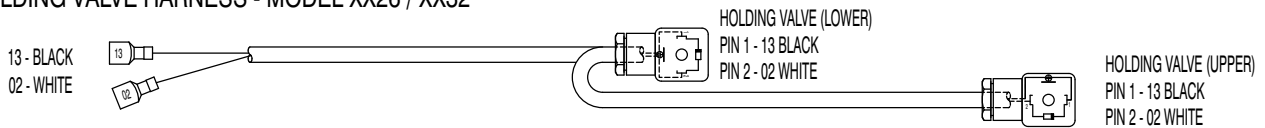

M146588AA4_S3

3.15 Telematics Harness - ZTR

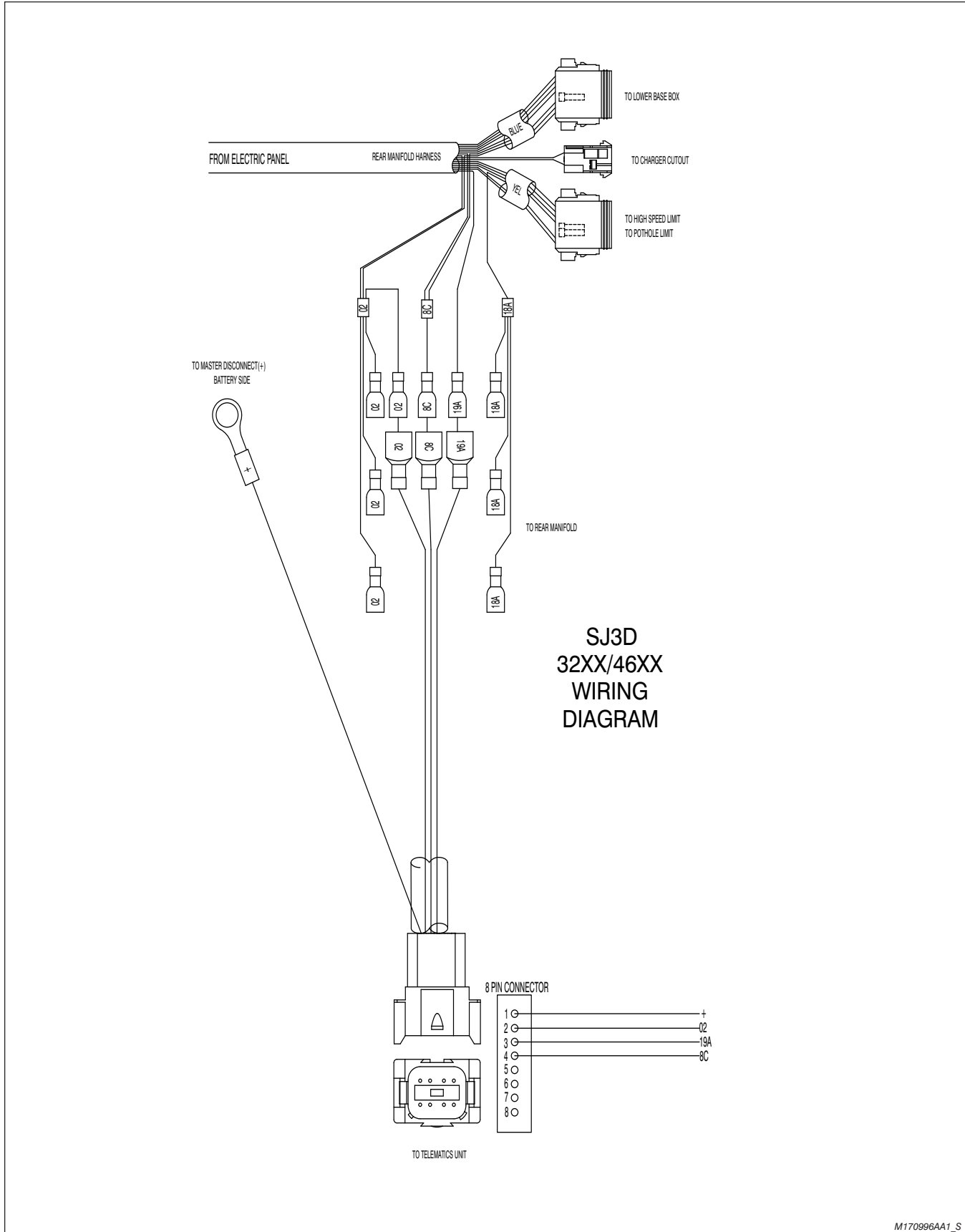

M170996AA1_S

3.16a Hydraulic Schematic (Models 322x)

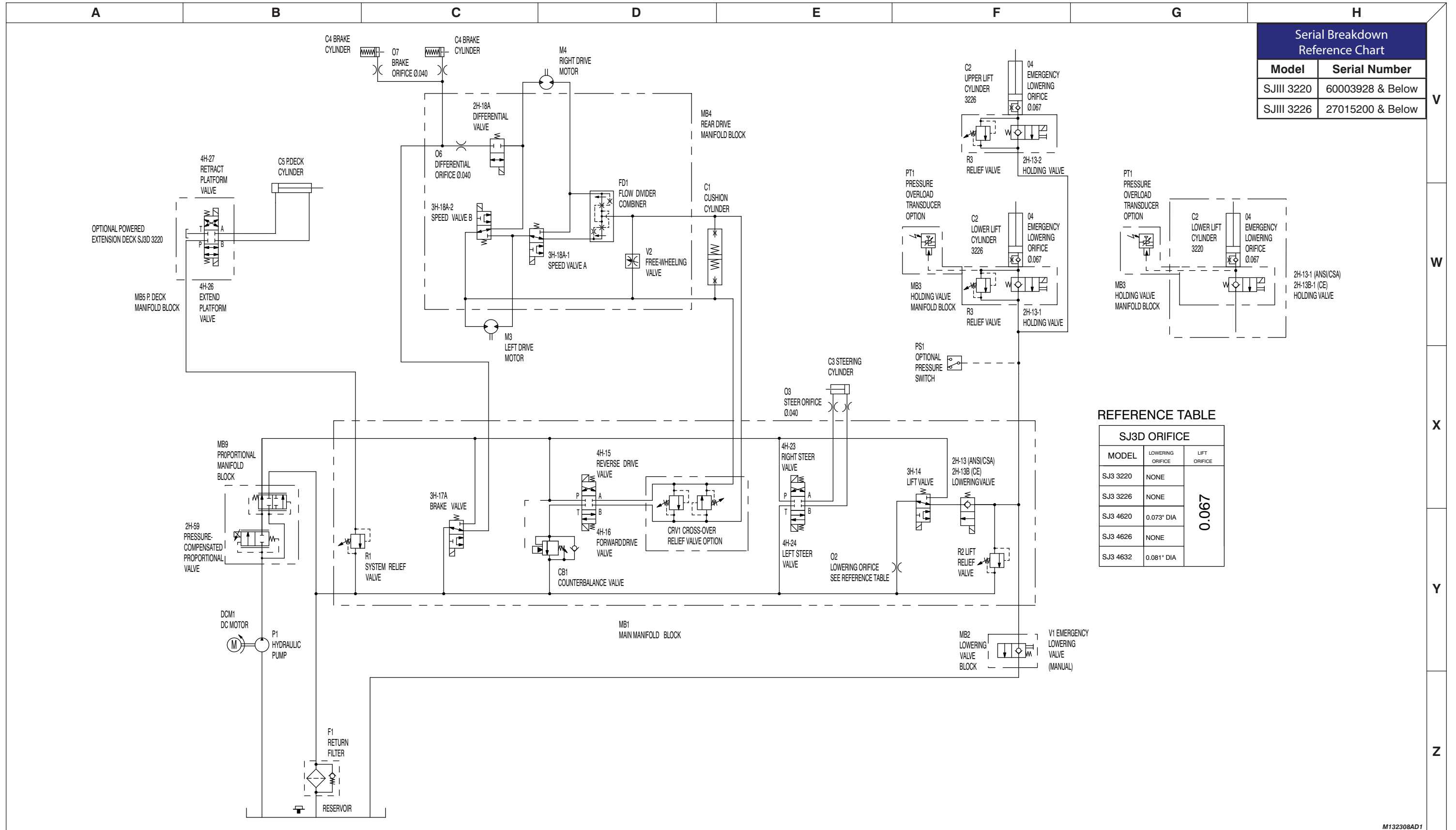

Serial Breakdown Reference Chart	
Model	Serial Number
SJIII 3220	60003928 & Below
SJIII 3226	27015200 & Below

REFERENCE TABLE

SJ3D ORIFICE		
MODEL	LOWERING ORIFICE	LIFT ORIFICE
SJ3 3220	NONE	0.067
SJ3 3226	NONE	
SJ3 4620	0.073" DIA	
SJ3 4626	NONE	
SJ3 4632	0.081" DIA	

M132308AD1

3.17a Hydraulic Schematic (Models 46xx)

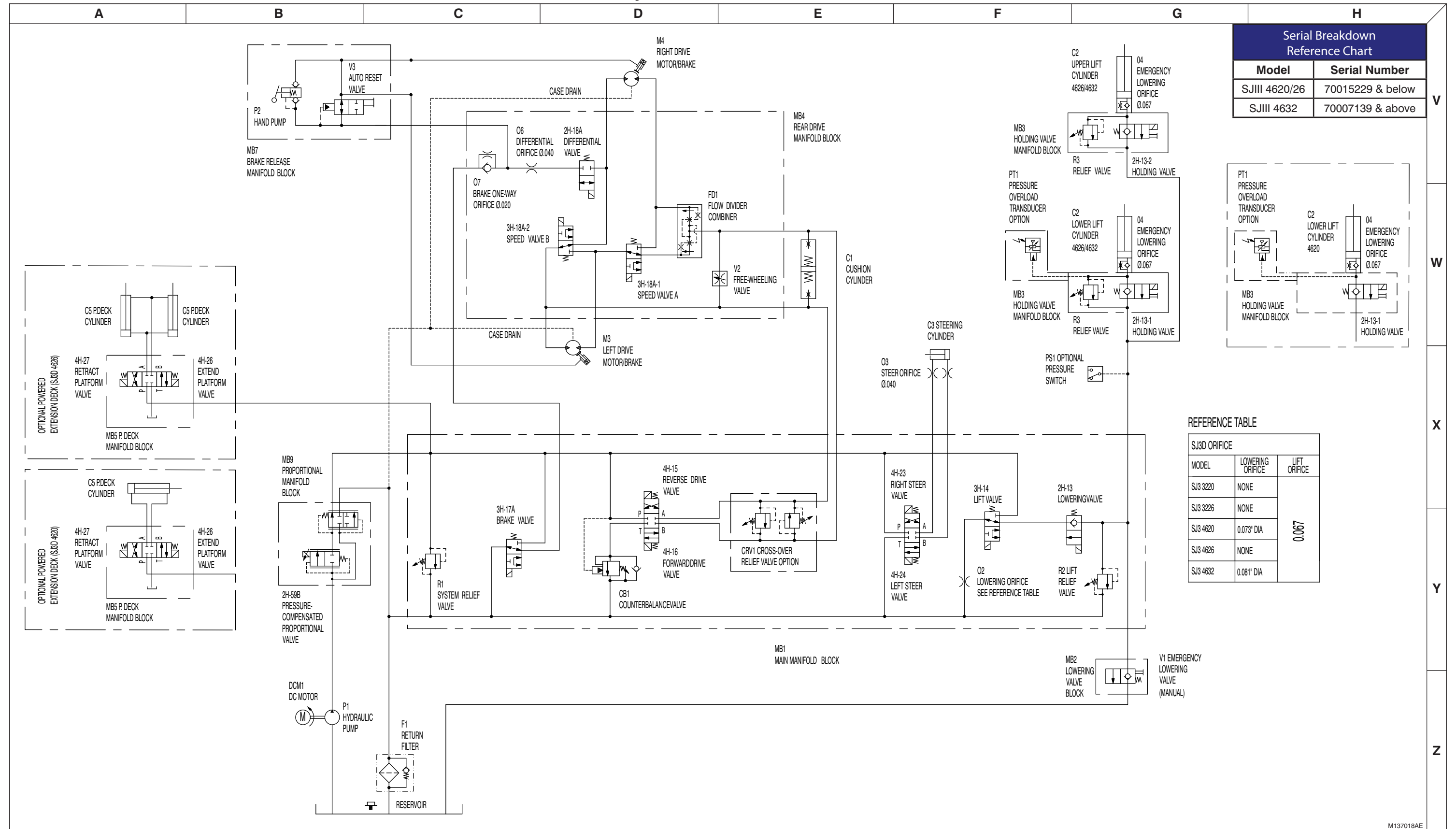

Serial Breakdown Reference Chart	
Model	Serial Number
SJIII 4620/26	70015229 & below
SJIII 4632	70007139 & above

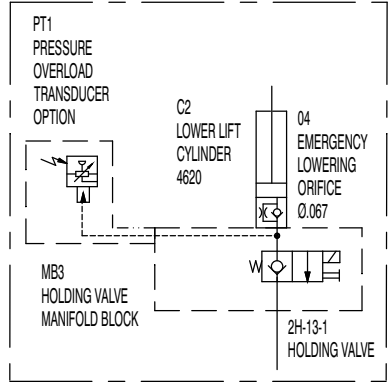

REFERENCE TABLE

SJ3D ORIFICE		
MODEL	LOWERING ORIFICE	LIFT ORIFICE
SJ3 3220	NONE	0.067
SJ3 3226	NONE	
SJ3 4620	0.073" DIA	
SJ3 4626	NONE	
SJ3 4632	0.081" DIA	

3.17b Hydraulic Schematic (Models 46xx)

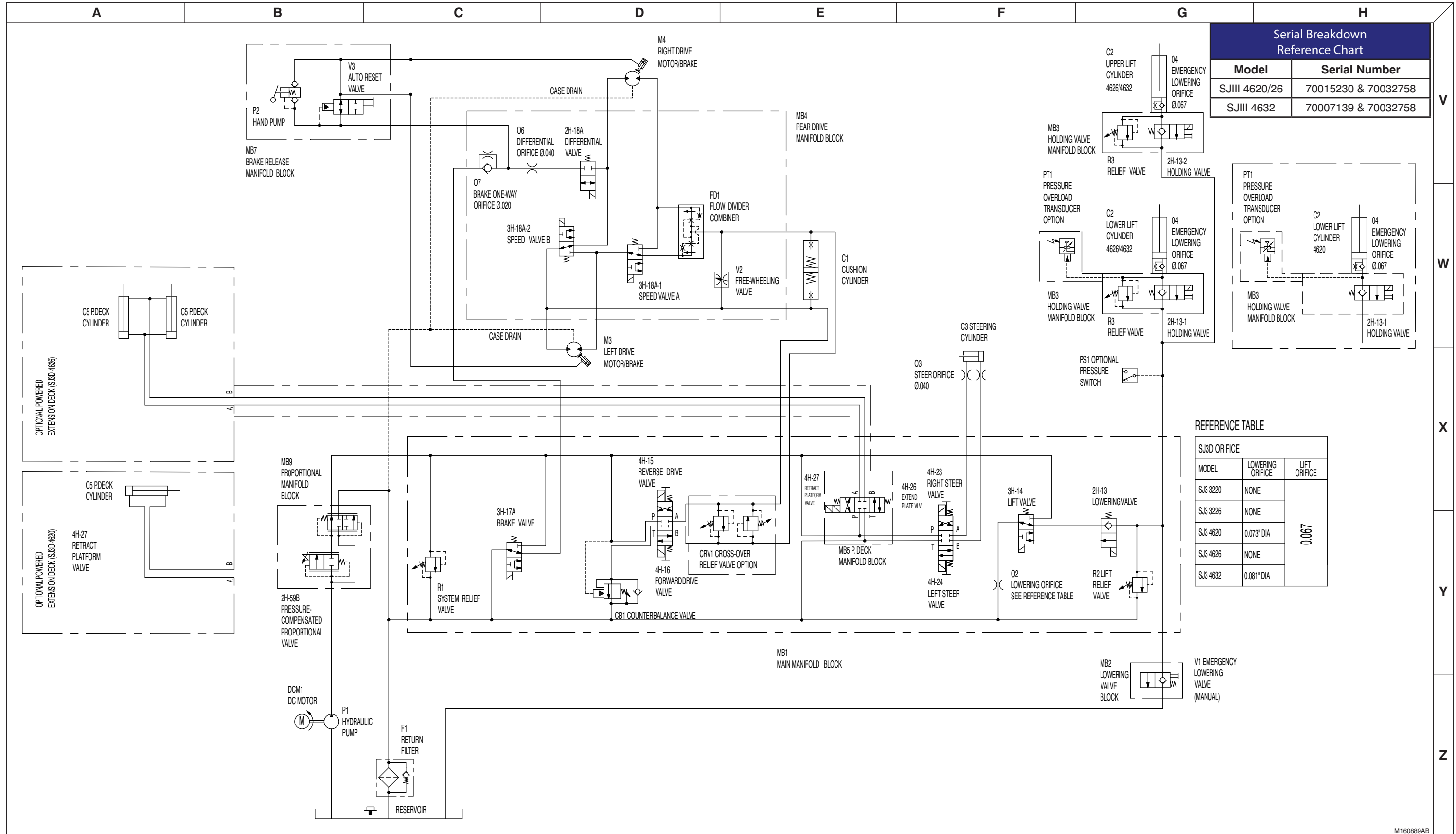

Serial Breakdown Reference Chart	
Model	Serial Number
SJIII 4620/26	70015230 & 70032758
SJIII 4632	70007139 & 70032758

SJS3 ORIFICE		
MODEL	LOWERING ORIFICE	LIFT ORIFICE
SJS 3220	NONE	0.067
SJS 3226	NONE	
SJS 4620	0.073" DIA	
SJS 4626	NONE	
SJS 4632	0.081" DIA	

3.17c Hydraulic Schematic (Models 46xx)

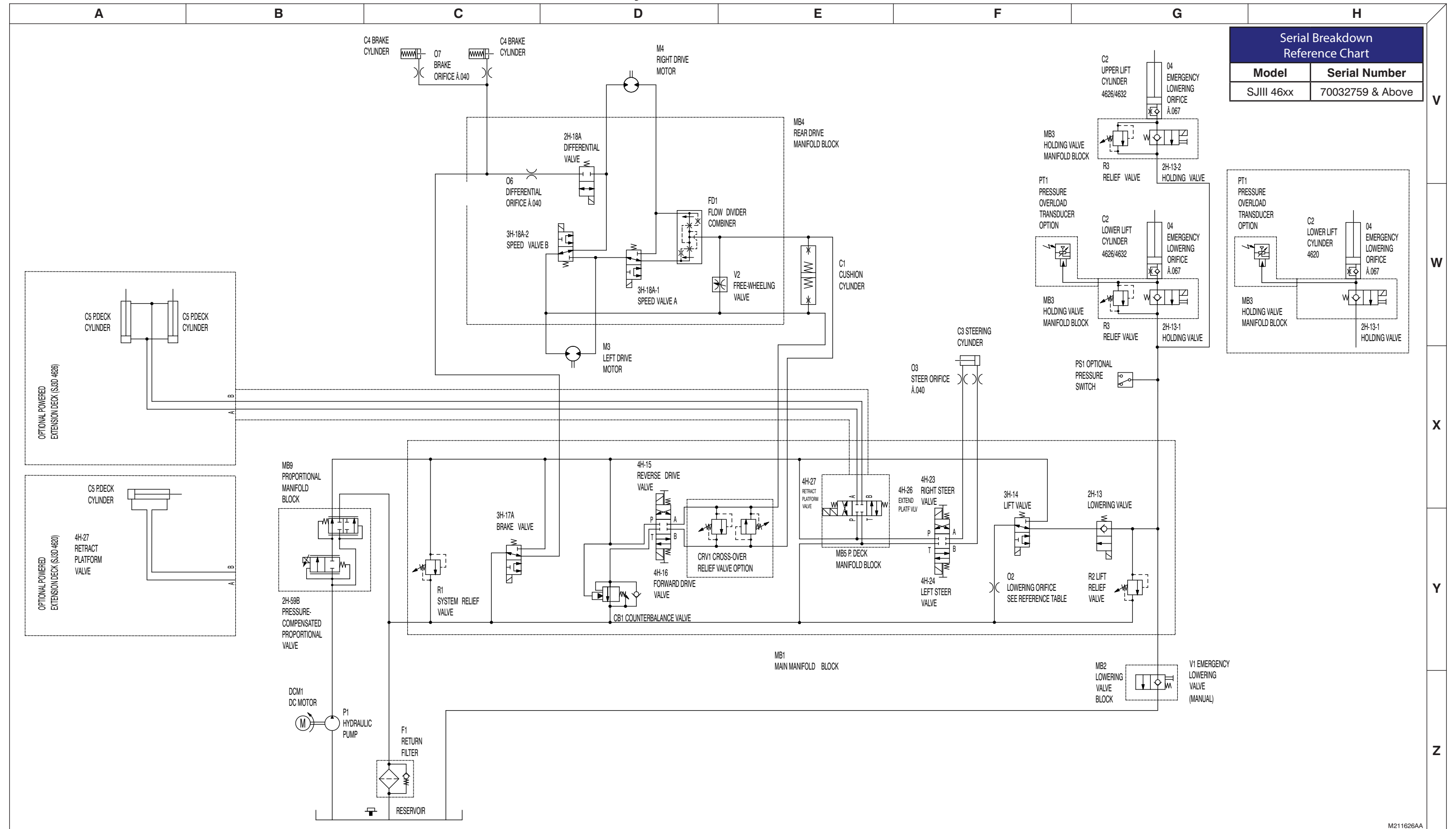

Serial Breakdown Reference Chart	
Model	Serial Number
SJIII 46xx	70032759 & Above

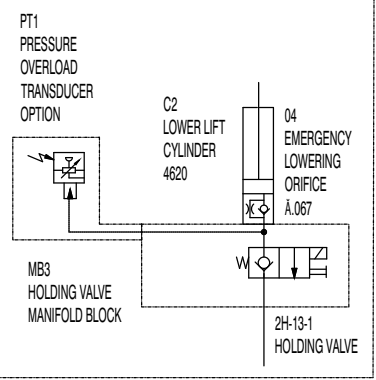

3.18 Main Manifold Harness

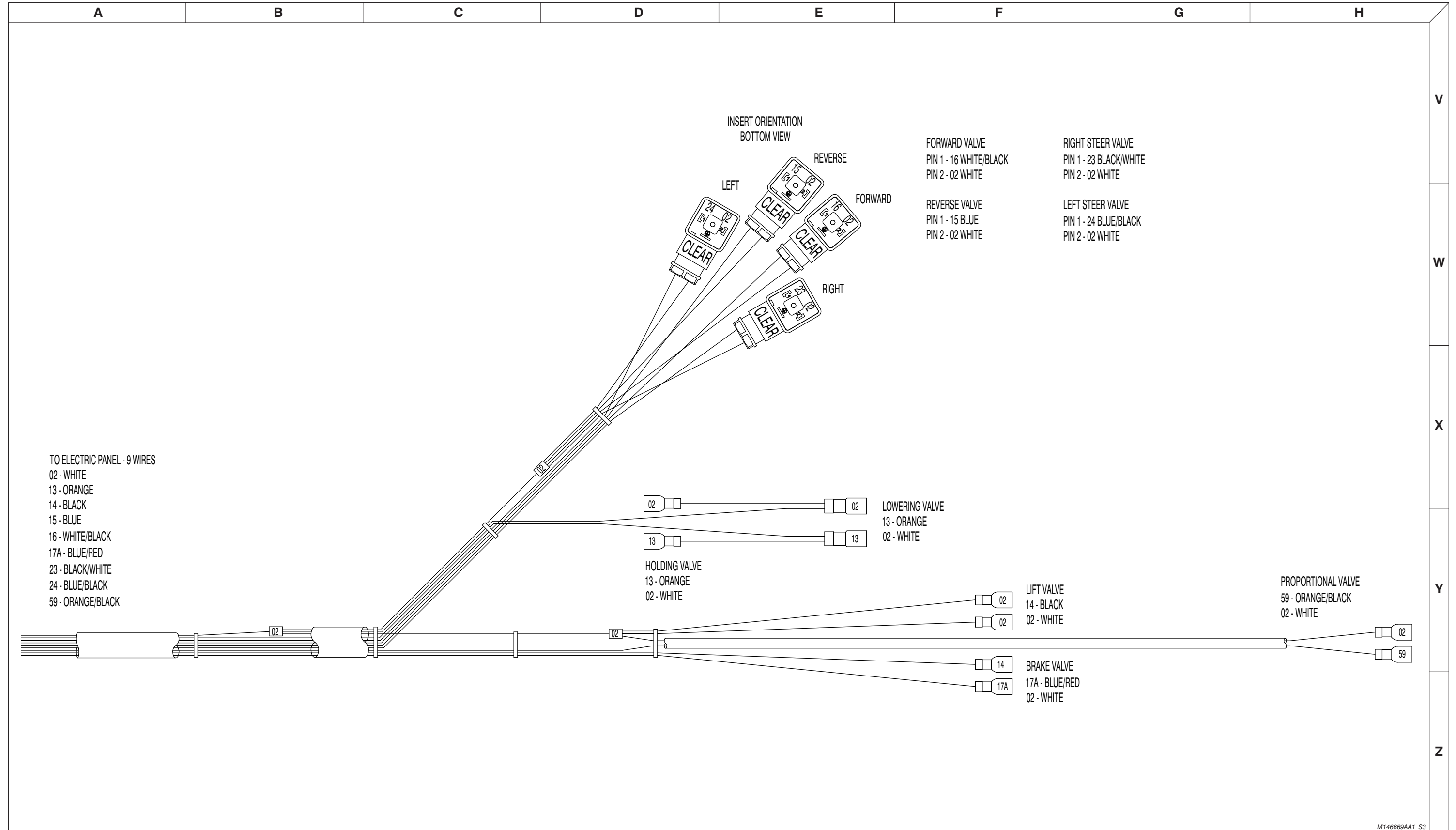

M146669AA1_S3

3.19 Main Manifold Harness (EE-Rated)

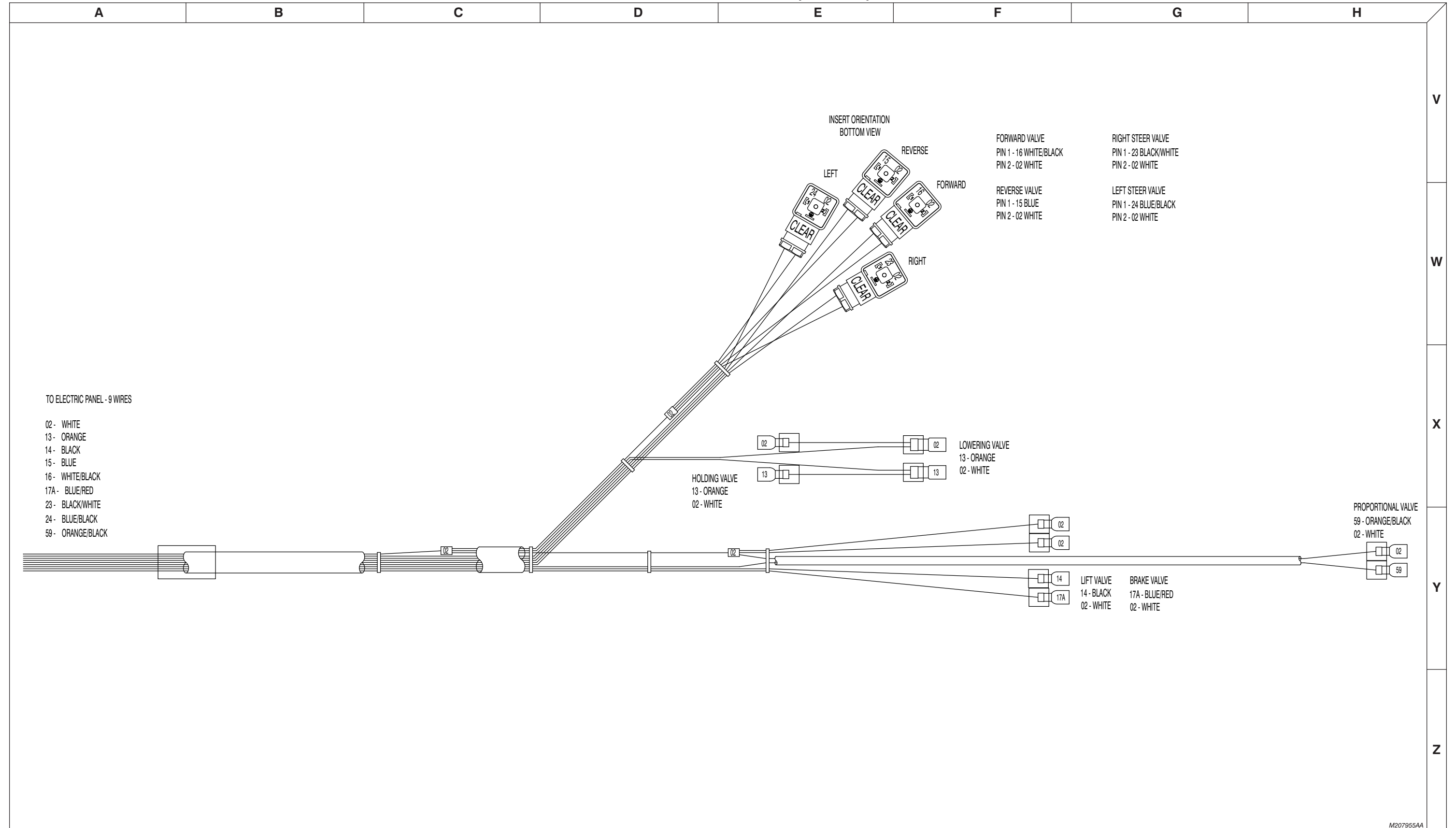

3.20 Elevate Telematics Harness

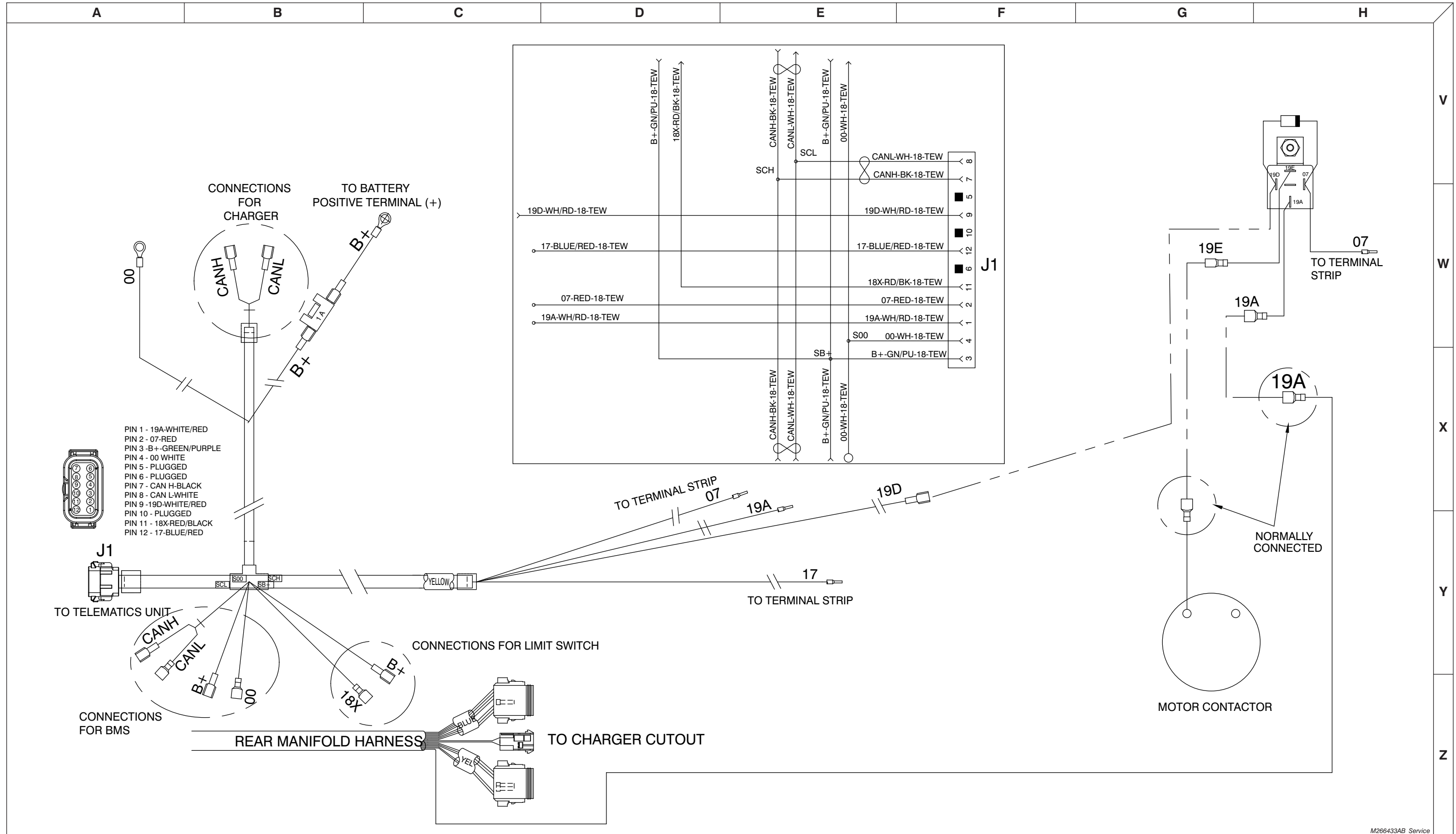

- PIN 1 - 19A-WHITE/RED
- PIN 2 - 07-RED
- PIN 3 - B+-GREEN/PURPLE
- PIN 4 - 00 WHITE
- PIN 5 - PLUGGED
- PIN 6 - PLUGGED
- PIN 7 - CAN H-BLACK
- PIN 8 - CAN L-WHITE
- PIN 9 - 19D-WHITE/RED
- PIN 10 - PLUGGED
- PIN 11 - 18X-RED/BLACK
- PIN 12 - 17-BLUE/RED

M266433AB_Service

3.21a Electrical Panel Diagram

Serial Breakdown Reference Chart	
Model	Serial Number
SJIII 3220	60006146 & Below
SJIII 3226	27028841 & Below
SJIII 46xx	70028673 & Below

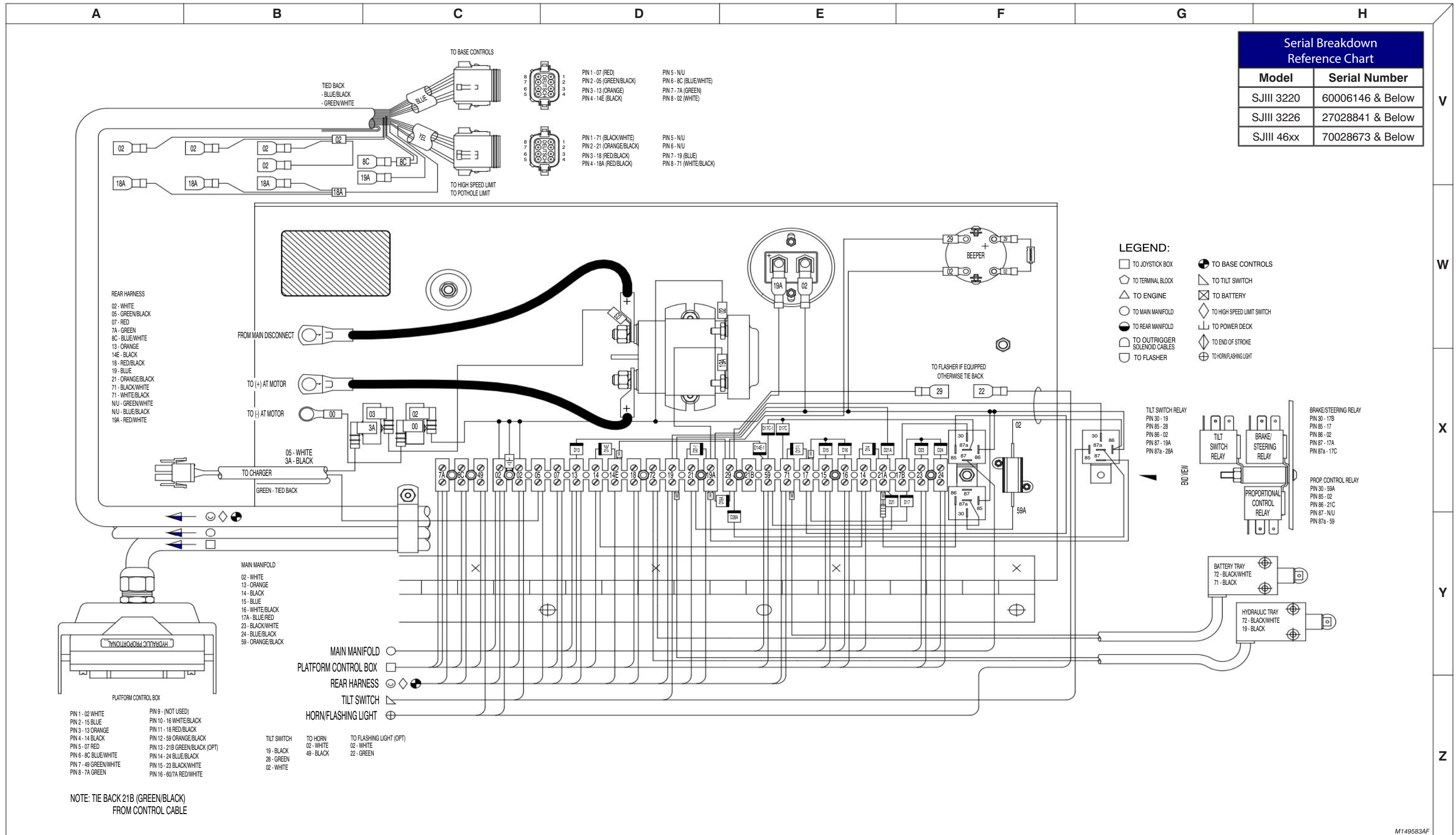

M149583AF

3.21b Electrical Panel Diagram

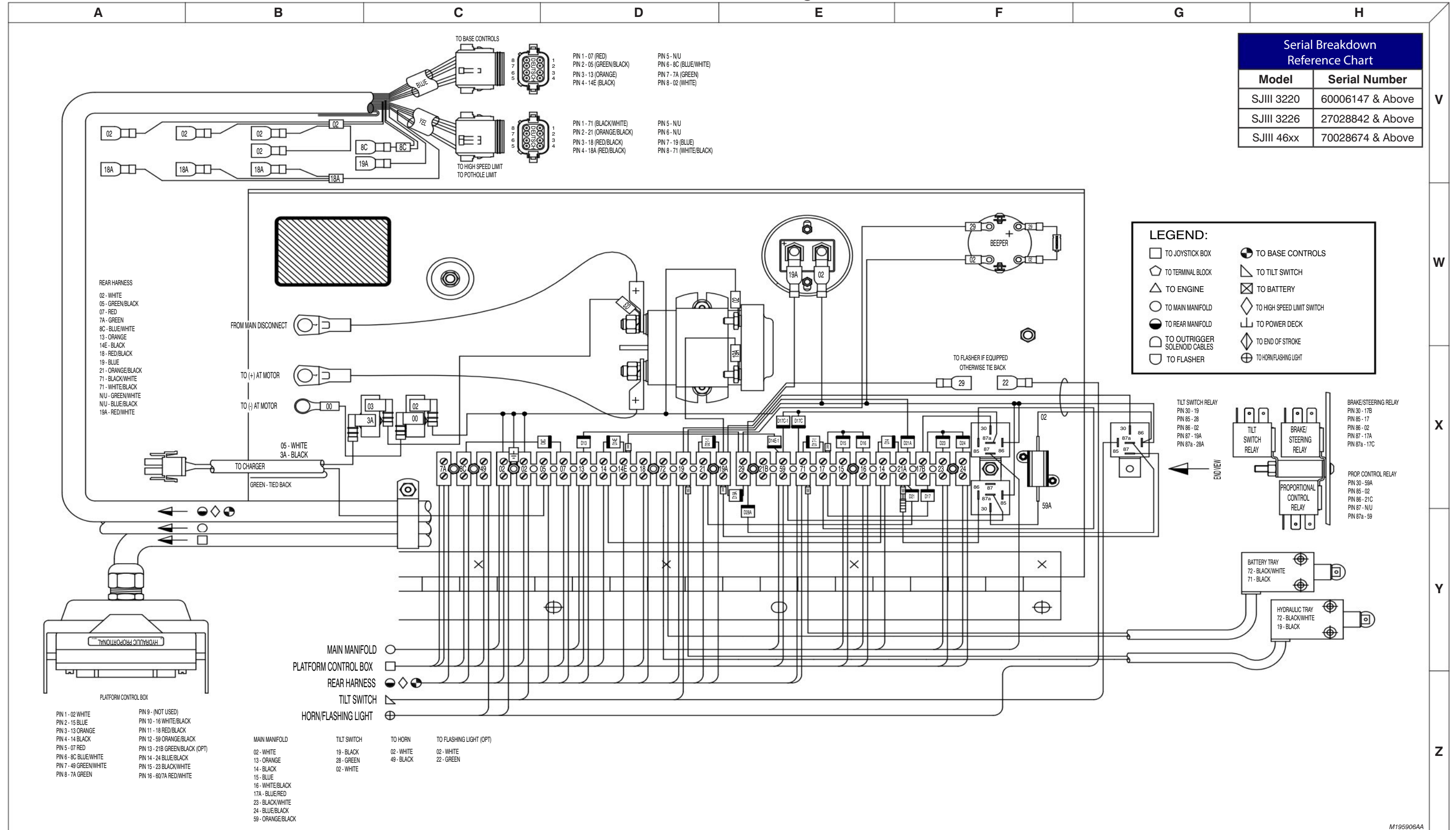

3.22b Electrical Panel Diagram with Power Deck

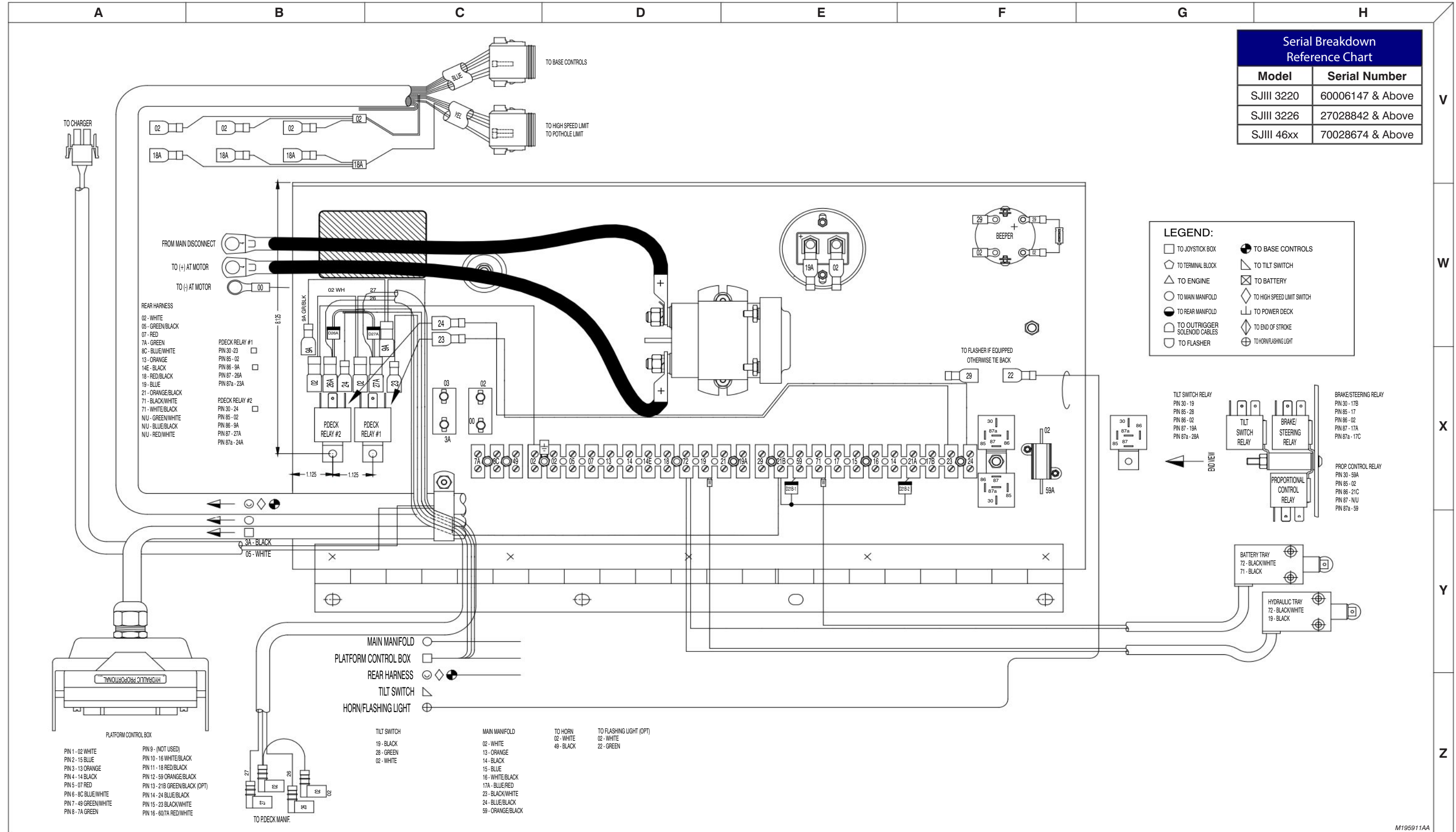

3.23a Electrical Panel Diagram (EE Rated)

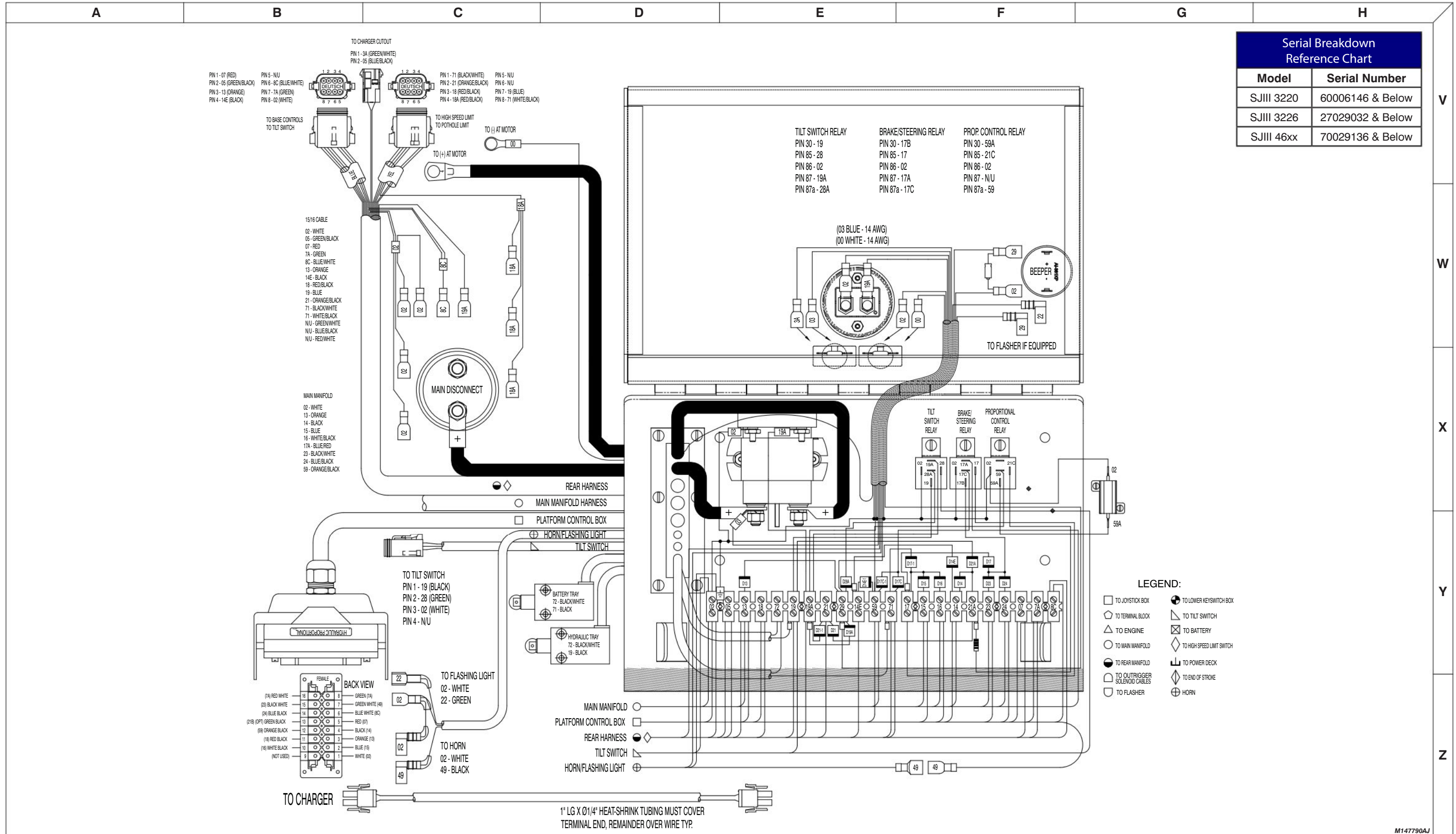

3.23b Electrical Panel Diagram (EE Rated)

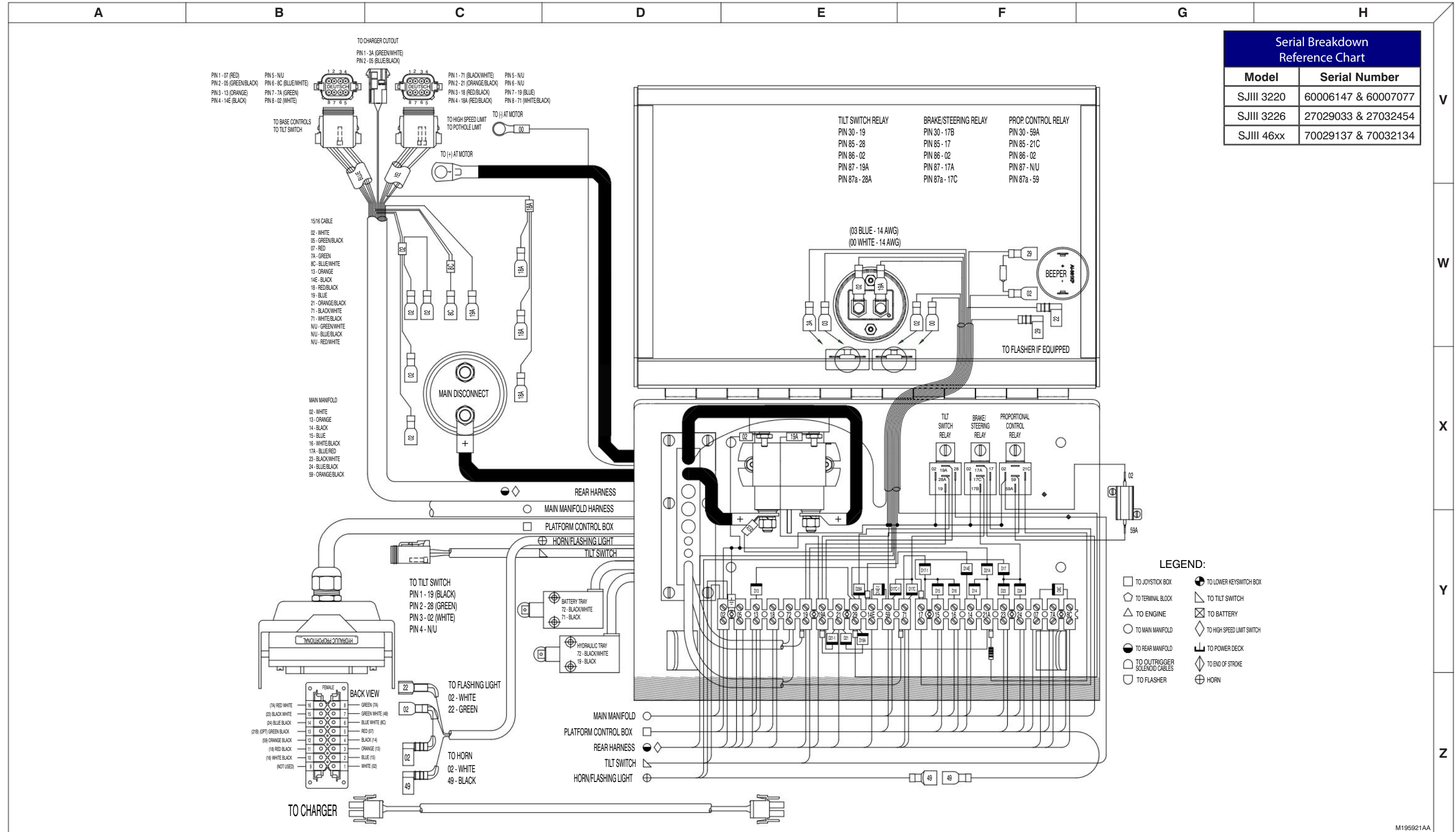

3.23c Electrical Panel Diagram (EE Rated)

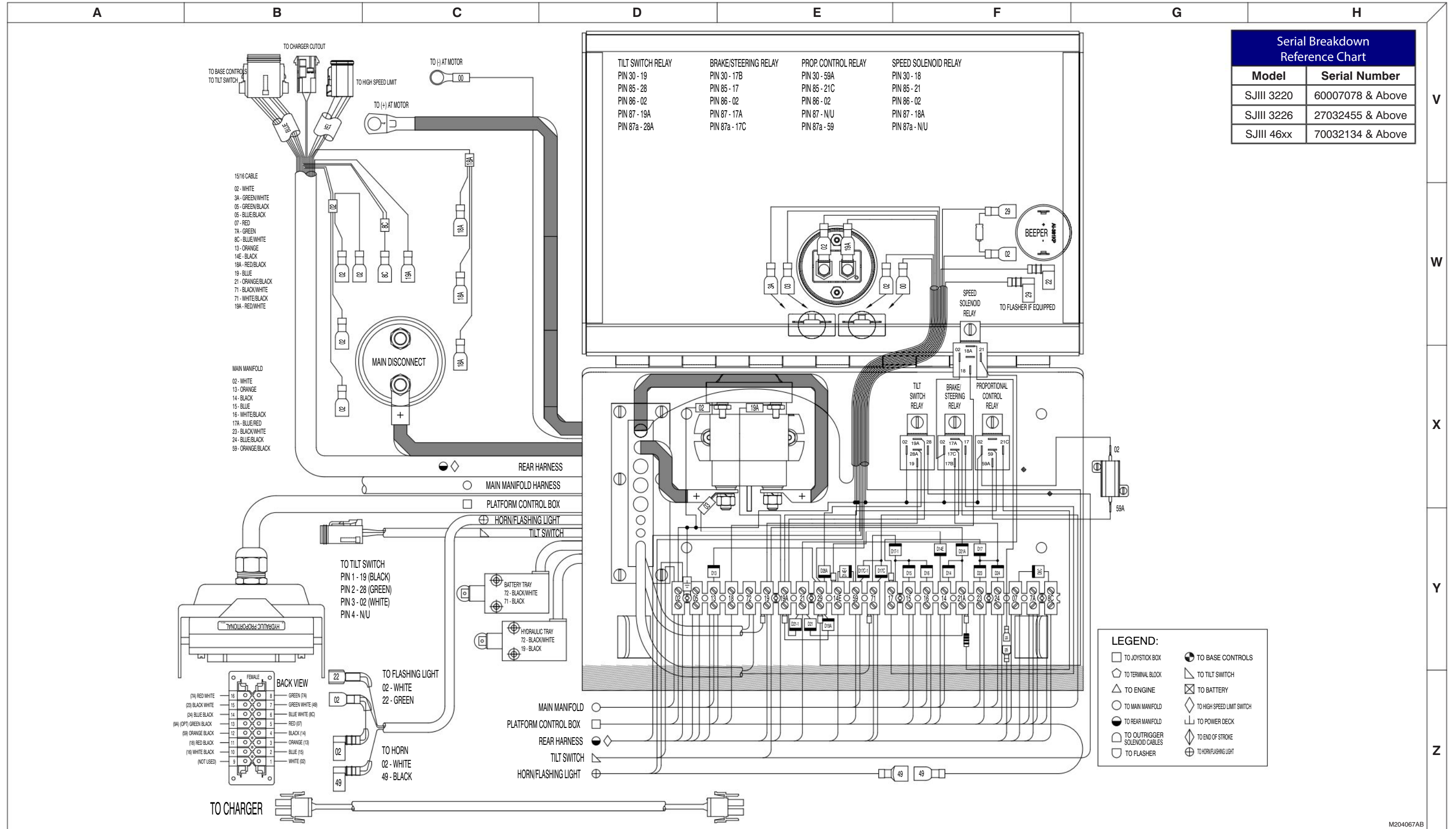

3.24a Electrical Panel Diagram (EE Rated) with Power Deck

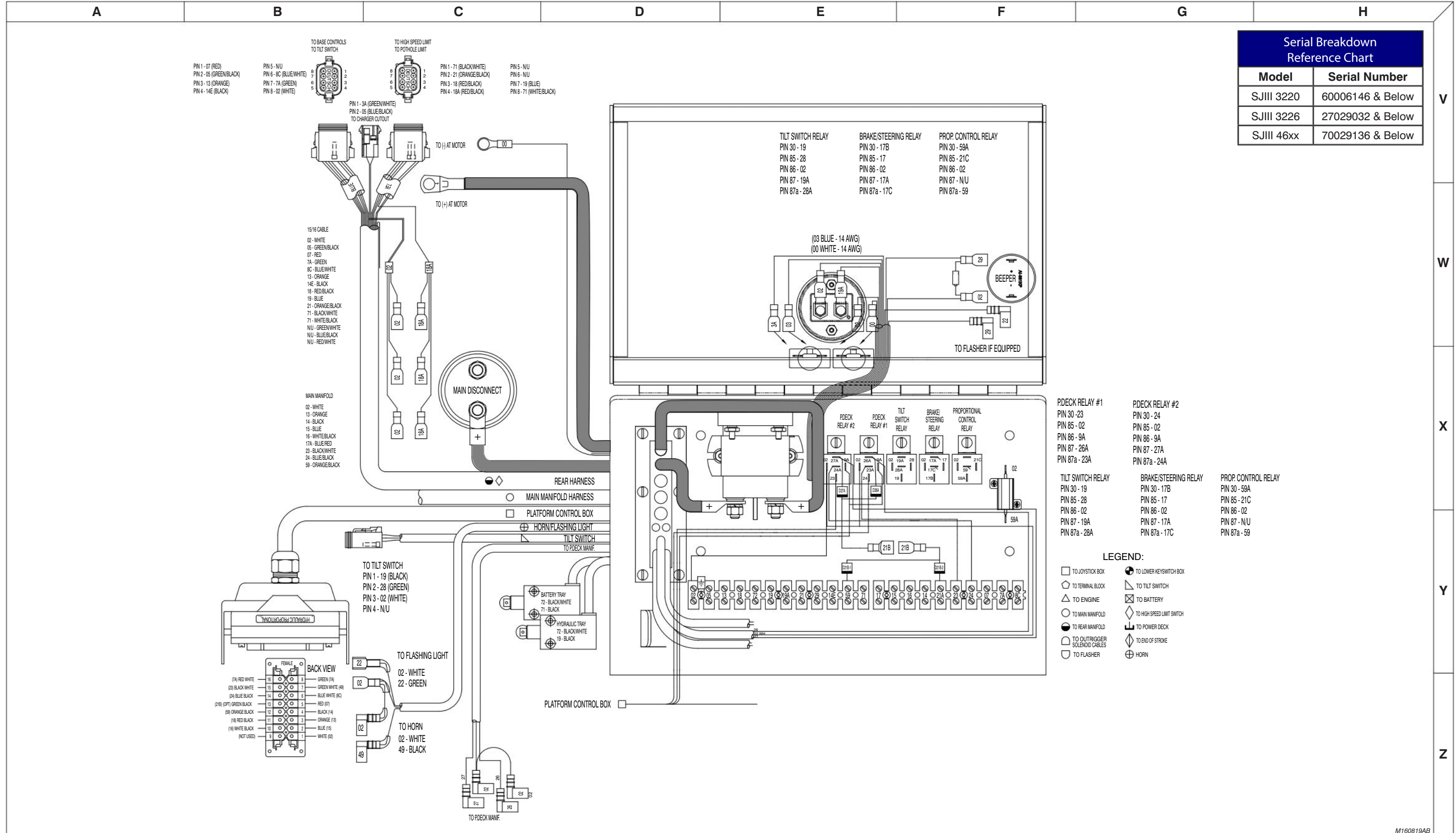

Serial Breakdown Reference Chart	
Model	Serial Number
SJIII 3220	60006146 & Below
SJIII 3226	27029032 & Below
SJIII 46xx	70029136 & Below

PDECK RELAY #1 PIN 30-23 PIN 85-02 PIN 86-9A PIN 87-26A PIN 87a-23A	PDECK RELAY #2 PIN 30-24 PIN 85-02 PIN 86-9A PIN 87-27A PIN 87a-24A	PROP. CONTROL RELAY PIN 30-59A PIN 85-21C PIN 86-02 PIN 87-N/U PIN 87a-59
TILT SWITCH RELAY PIN 30-19 PIN 85-28 PIN 86-02 PIN 87-19A PIN 87a-28A	BRAKE/STEERING RELAY PIN 30-17B PIN 85-17 PIN 86-02 PIN 87-17A PIN 87a-17C	

LEGEND:

- TO JOYSTICK BOX
- ⊙ TO LOWER KEYSWITCH BOX
- ⬠ TO TERMINAL BLOCK
- ⚡ TO TILT SWITCH
- ⚙ TO ENGINE
- ⊞ TO BATTERY
- ⊞ TO MAIN MANIFOLD
- ⊞ TO HIGH SPEED LIMIT SWITCH
- ⊞ TO REAR MANIFOLD
- ⊞ TO POWER DECK
- ⊞ TO OUTRIGGER SOLENOID CABLES
- ⊞ TO END OF STROKE
- ⊞ TO FLASHER
- ⊞ HORN

- PIN 1-07 (RED)
- PIN 2-05 (GREEN/BLACK)
- PIN 3-13 (ORANGE)
- PIN 4-14E (BLACK)
- PIN 5-N/U
- PIN 6-8C (BLUE/WHITE)
- PIN 7-7A (GREEN)
- PIN 8-02 (WHITE)
- PIN 1-71 (BLACK/WHITE)
- PIN 2-21 (ORANGE/BLACK)
- PIN 3-18 (RED/BLACK)
- PIN 4-18A (RED/BLACK)
- PIN 5-N/U
- PIN 6-N/U
- PIN 7-19 (BLUE)
- PIN 8-71 (WHITE/BLACK)

- 15/16 CABLE
- 02- WHITE
 - 05- GREEN/BLACK
 - 07- RED
 - 7A- GREEN
 - 8C- BLUE/WHITE
 - 13- ORANGE
 - 14E- BLACK
 - 18- RED/BLACK
 - 19- BLUE
 - 21- ORANGE/BLACK
 - 71- BLACK/WHITE
 - 71- WHITE/BLACK
 - N/U- GREEN/WHITE
 - N/U- BLUE/BLACK
 - N/U- RED/WHITE

- MAIN MANIFOLD
- 02- WHITE
 - 13- ORANGE
 - 14- BLACK
 - 15- BLUE
 - 16- WHITE/BLACK
 - 17A- BLUE/RED
 - 23- BLACK/WHITE
 - 24- BLUE/BLACK
 - 59- ORANGE/BLACK

- BACK VIEW
- (7A) RED WHITE
 - (03) BLACK WHITE
 - (04) BLUE BLACK
 - (21B) GREEN BLACK
 - (8A) ORANGE BLACK
 - (18) RED BLACK
 - (16) WHITE BLACK (NOT USED)
 - GREEN (7A)
 - GREEN WHITE (49)
 - BLUE WHITE (8C)
 - RED (07)
 - BLACK (14)
 - ORANGE (13)
 - BLUE (15)
 - WHITE (02)

3.24b Electrical Panel Diagram (EE Rated) with Power Deck

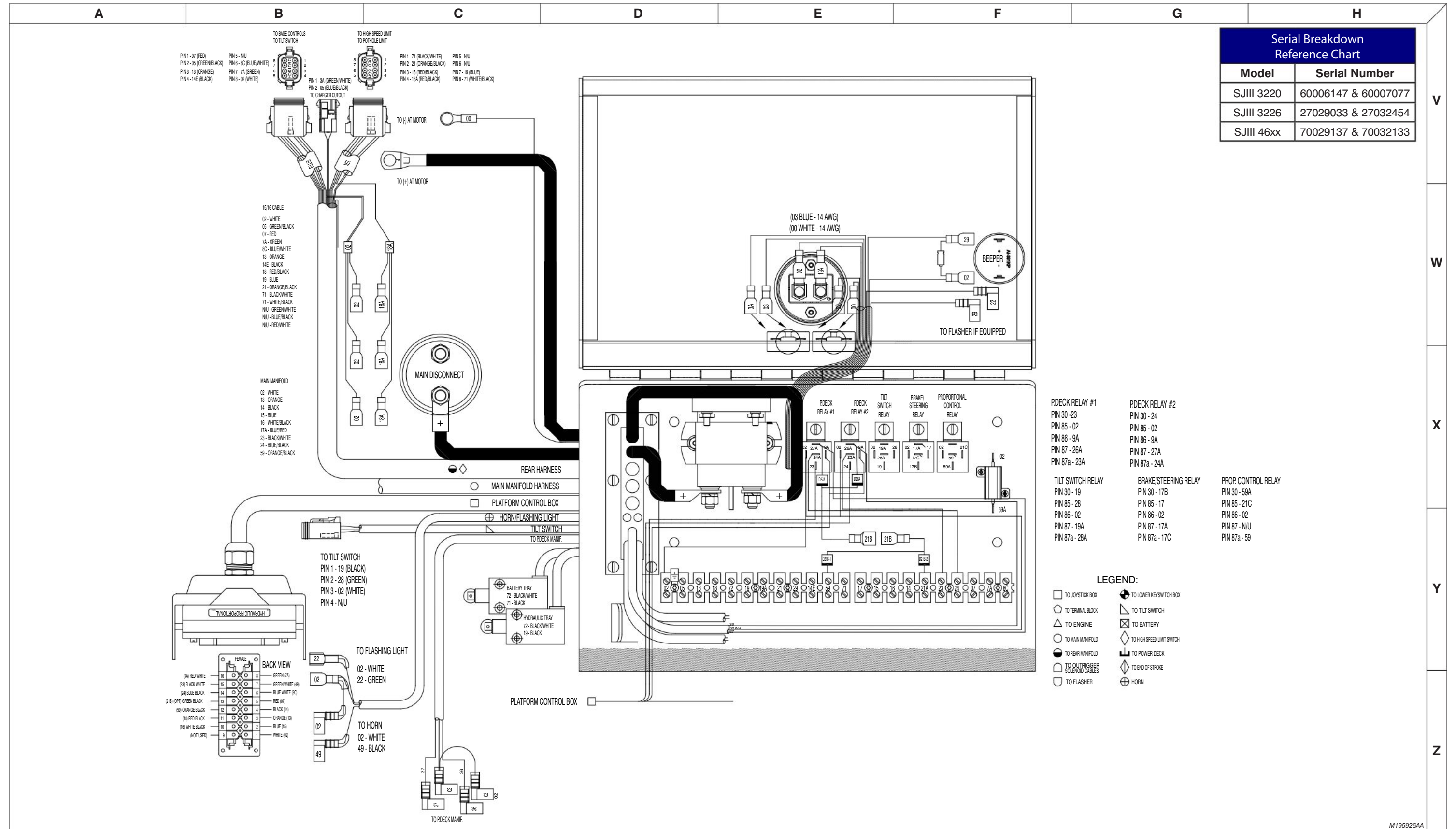

Serial Breakdown Reference Chart	
Model	Serial Number
SJIII 3220	60006147 & 60007077
SJIII 3226	27029033 & 27032454
SJIII 46xx	70029137 & 70032133

PDECK RELAY #1 PIN 30 - 23 PIN 85 - 02 PIN 86 - 9A PIN 87 - 26A PIN 87a - 23A	PDECK RELAY #2 PIN 30 - 24 PIN 85 - 02 PIN 86 - 9A PIN 87 - 27A PIN 87a - 24A	PROP. CONTROL RELAY PIN 30 - 59A PIN 85 - 21C PIN 86 - 02 PIN 87 - NU PIN 87a - 59
TILT SWITCH RELAY PIN 30 - 19 PIN 85 - 28 PIN 86 - 02 PIN 87 - 19A PIN 87a - 28A	BRAKE/STEERING RELAY PIN 30 - 17B PIN 85 - 17 PIN 86 - 02 PIN 87 - 17A PIN 87a - 17C	

3.24c Electrical Panel Diagram (EE Rated) with Power Deck

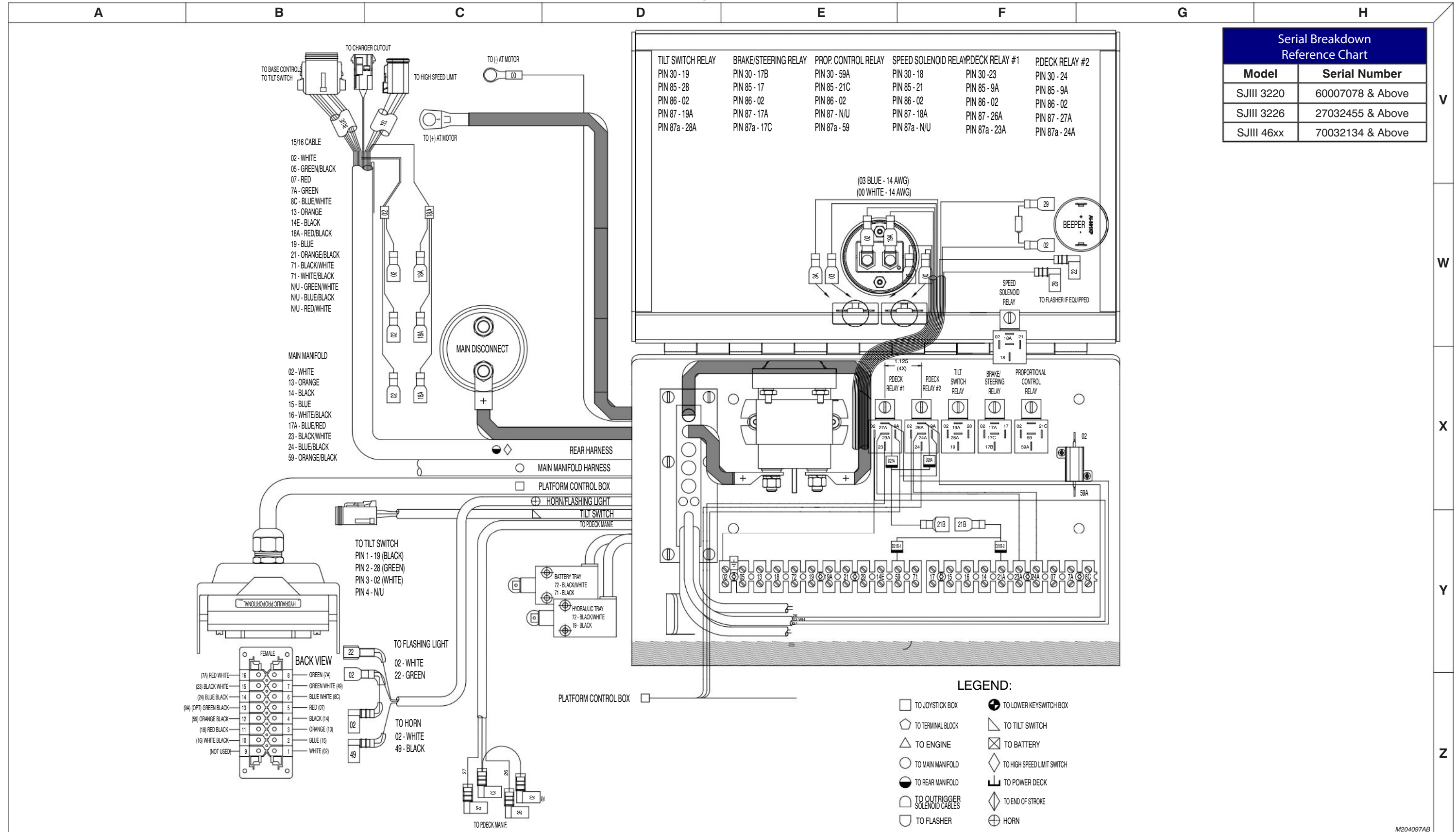

Serial Breakdown Reference Chart	
Model	Serial Number
SJIII 3220	60007078 & Above
SJIII 3226	27032455 & Above
SJIII 46xx	70032134 & Above

TILT SWITCH RELAY	BRAKE/STEERING RELAY	PROP. CONTROL RELAY	SPEED SOLENOID RELAY	DECK RELAY #1	DECK RELAY #2
PIN 30 - 19	PIN 30 - 17B	PIN 30 - 59A	PIN 30 - 18	PIN 30 - 23	PIN 30 - 24
PIN 85 - 28	PIN 85 - 17	PIN 85 - 21C	PIN 85 - 21	PIN 85 - 9A	PIN 85 - 9A
PIN 86 - 02	PIN 86 - 02	PIN 86 - 02	PIN 86 - 02	PIN 86 - 02	PIN 86 - 02
PIN 87 - 19A	PIN 87 - 17A	PIN 87 - N/U	PIN 87 - 18A	PIN 87 - 26A	PIN 87 - 27A
PIN 87a - 28A	PIN 87a - 17C	PIN 87a - 59	PIN 87a - N/U	PIN 87a - 23A	PIN 87a - 24A

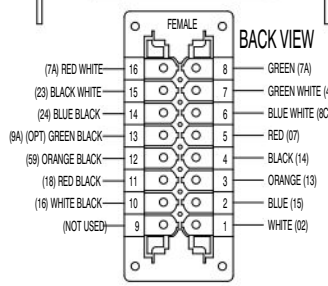

3.25b Electrical Panel Diagram - Inverter

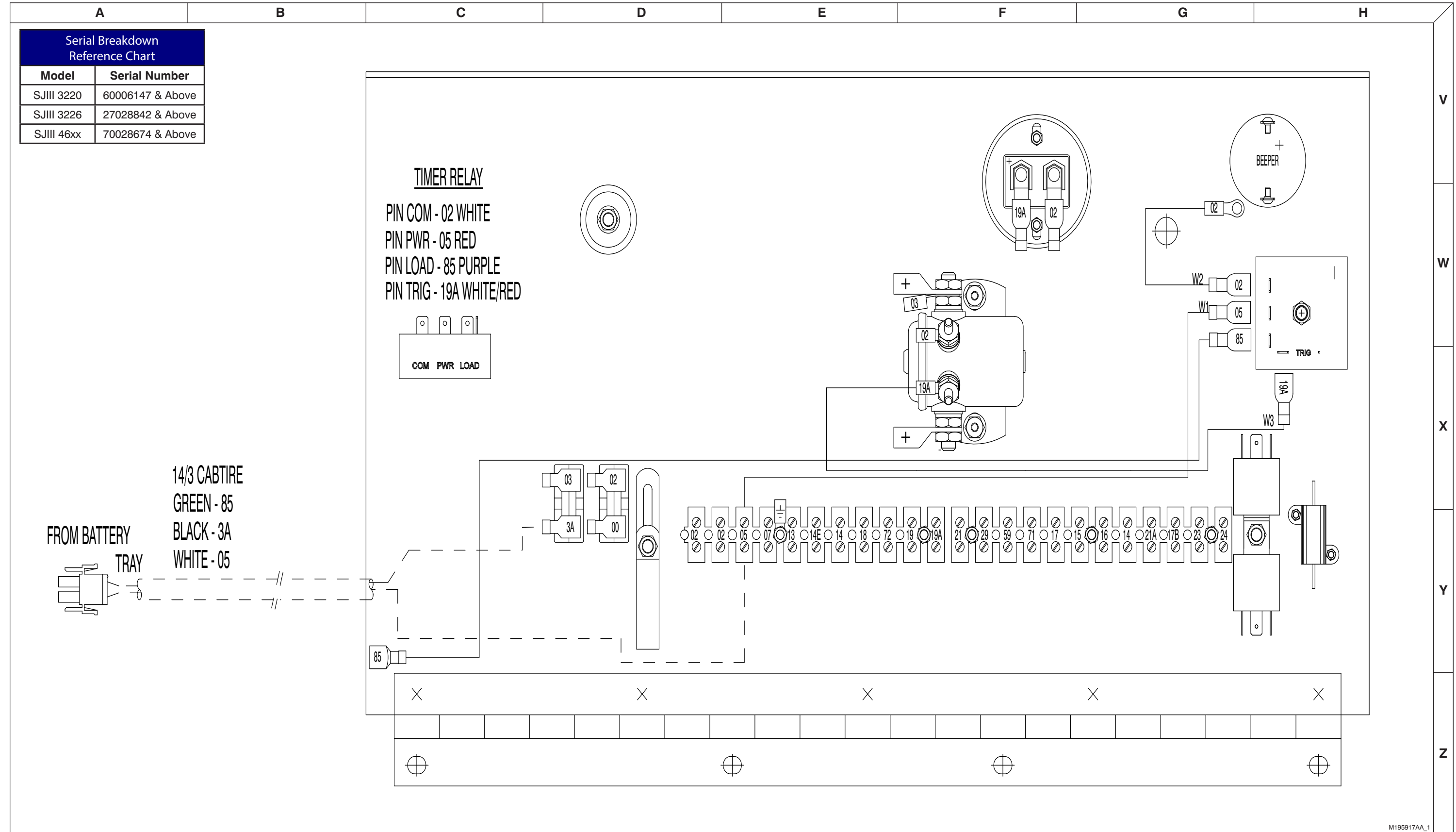

Serial Breakdown Reference Chart	
Model	Serial Number
SJIII 3220	60006147 & Above
SJIII 3226	27028842 & Above
SJIII 46xx	70028674 & Above

TIMER RELAY
 PIN COM - 02 WHITE
 PIN PWR - 05 RED
 PIN LOAD - 85 PURPLE
 PIN TRIG - 19A WHITE/RED

FROM BATTERY TRAY
 14/3 CABTIRE
 GREEN - 85
 BLACK - 3A
 WHITE - 05

M195917AA_1

3.26a Electrical Panel Diagram with Power Deck - Inverter

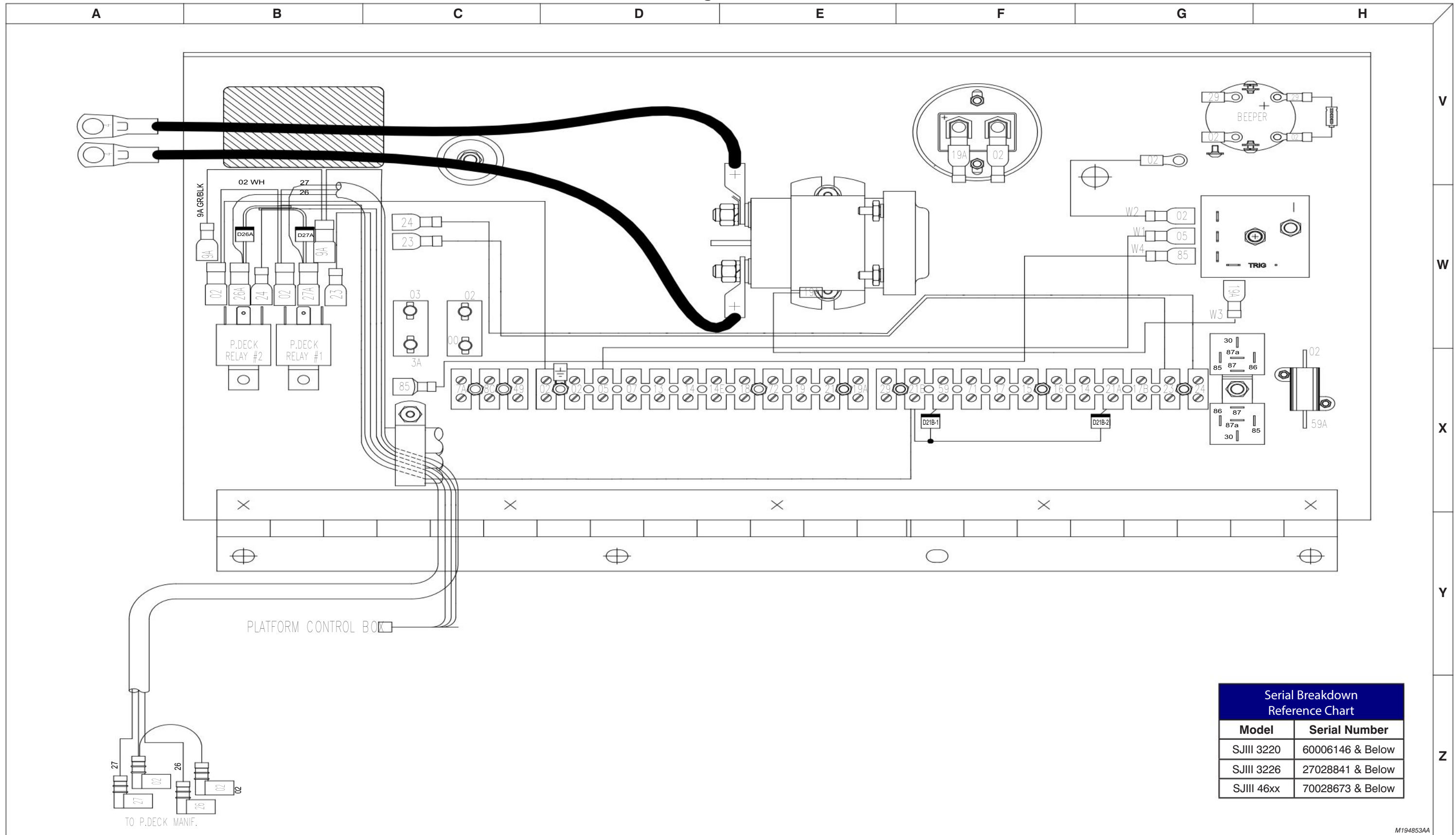

Serial Breakdown Reference Chart	
Model	Serial Number
SJIII 3220	60006146 & Below
SJIII 3226	27028841 & Below
SJIII 46xx	70028673 & Below

3.26b Electrical Panel Diagram with Power Deck - Inverter

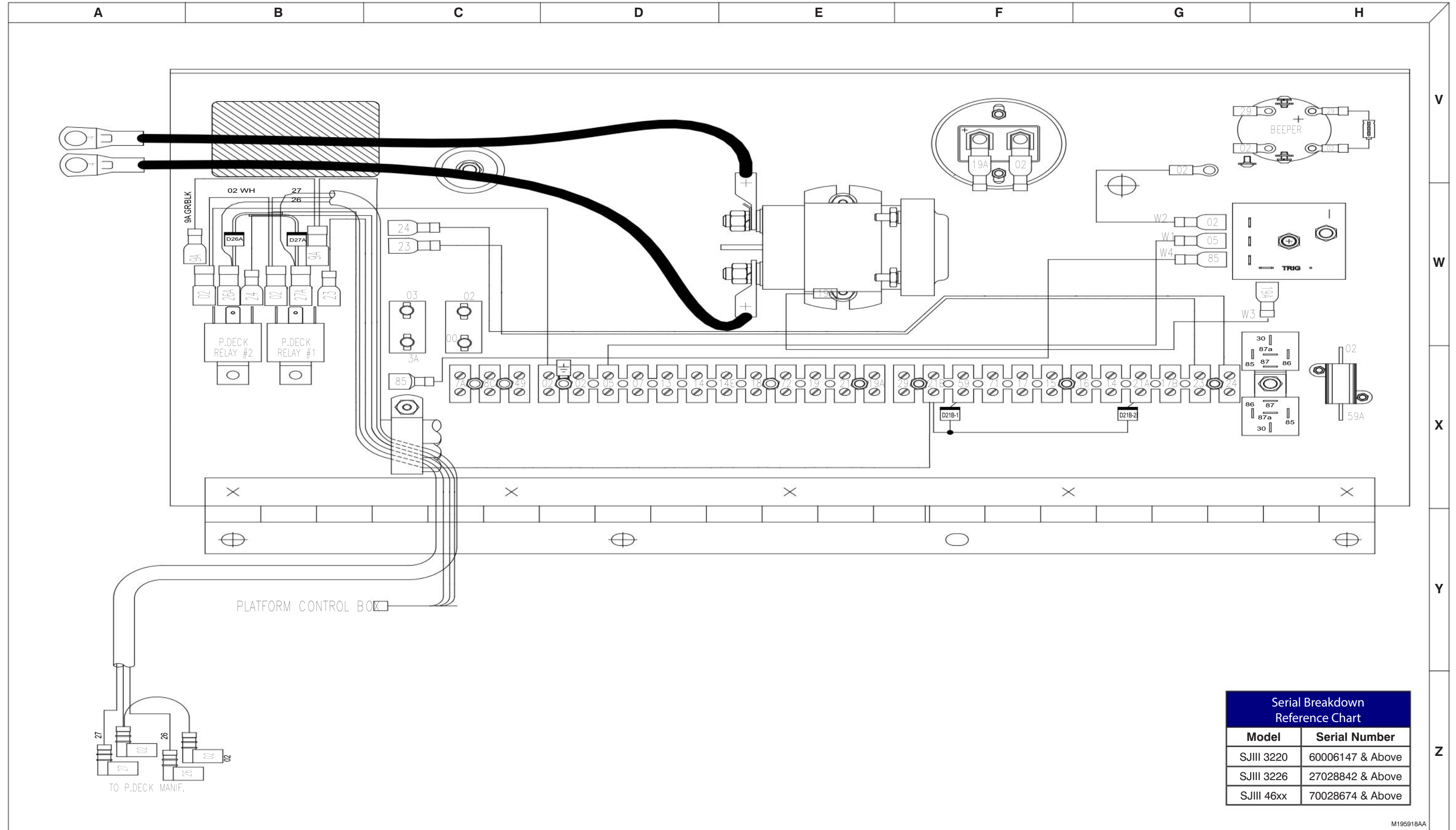

Serial Breakdown Reference Chart	
Model	Serial Number
SJIII 3220	60006147 & Above
SJIII 3226	27028842 & Above
SJIII 46xx	70028674 & Above

M195918AA

3.27 Horn/Tilt Switch/Flashing Light Diagram

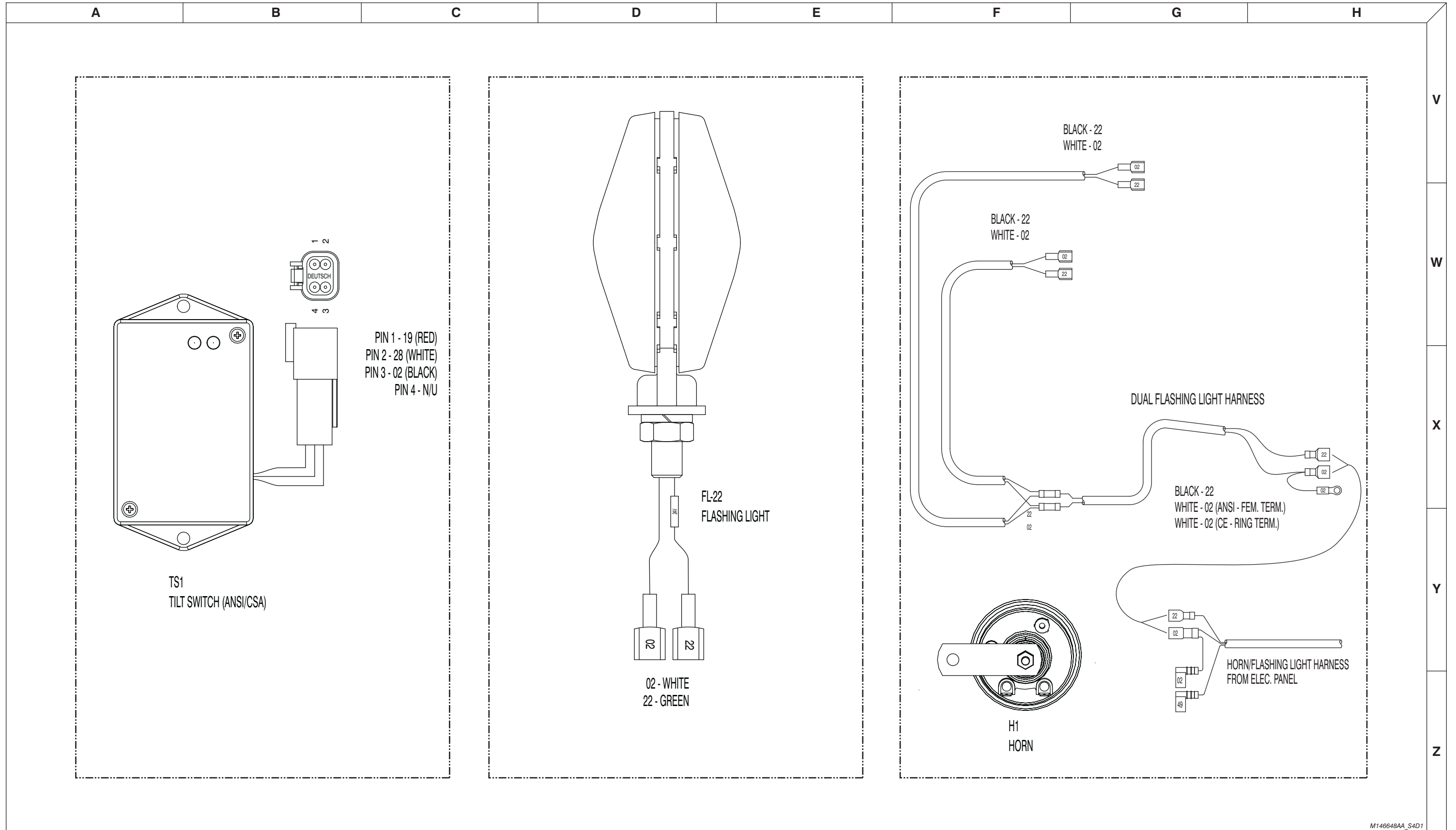

M146648AA_S4D1

3.28b Electrical Schematic (ANSI/CSA except EE rated - Equipped with no options)

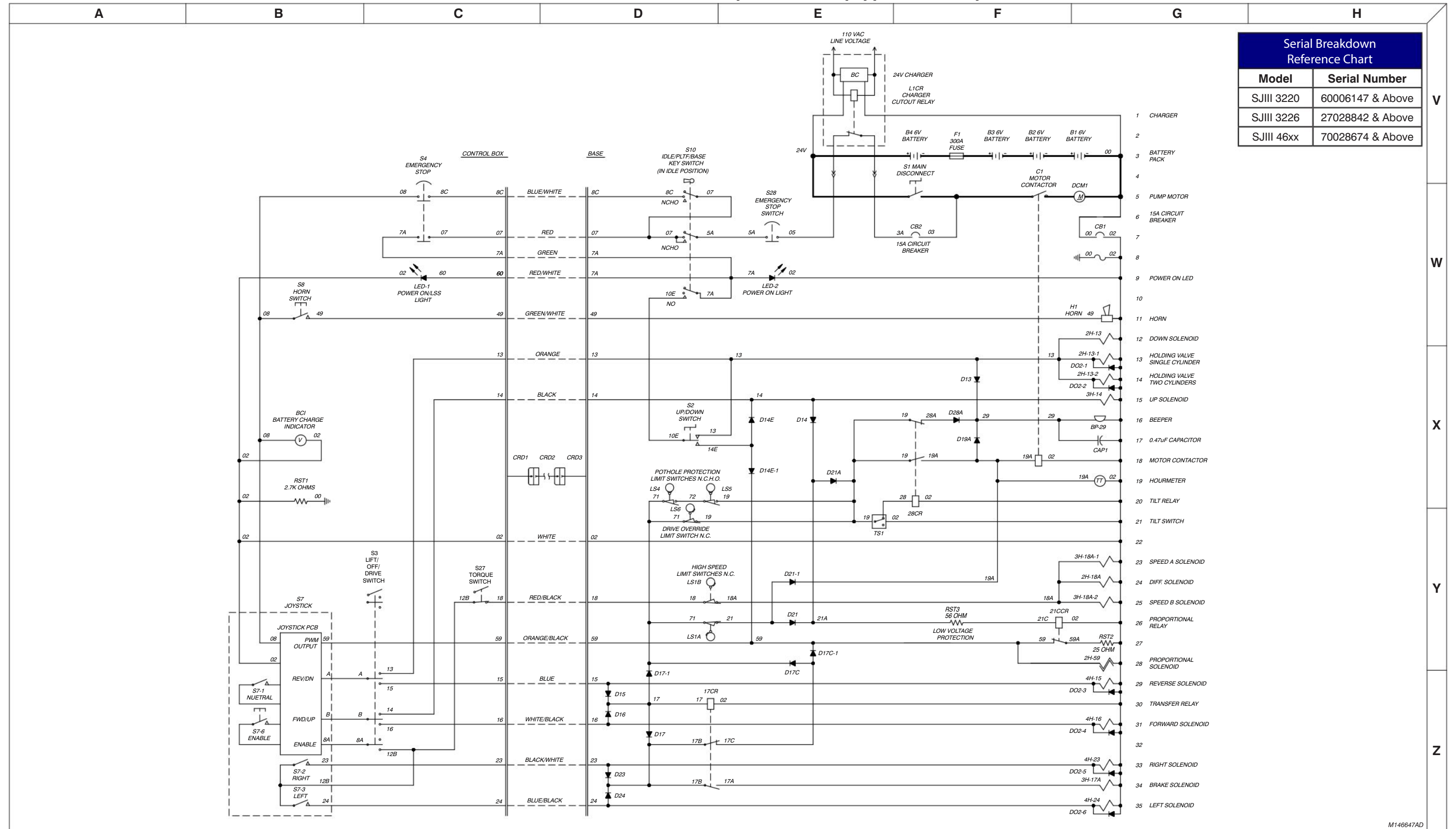

Serial Breakdown Reference Chart	
Model	Serial Number
SJIII 3220	60006147 & Above
SJIII 3226	27028842 & Above
SJIII 46xx	70028674 & Above

3.29a Electrical Schematic (EE Rated - Equipped with no options)

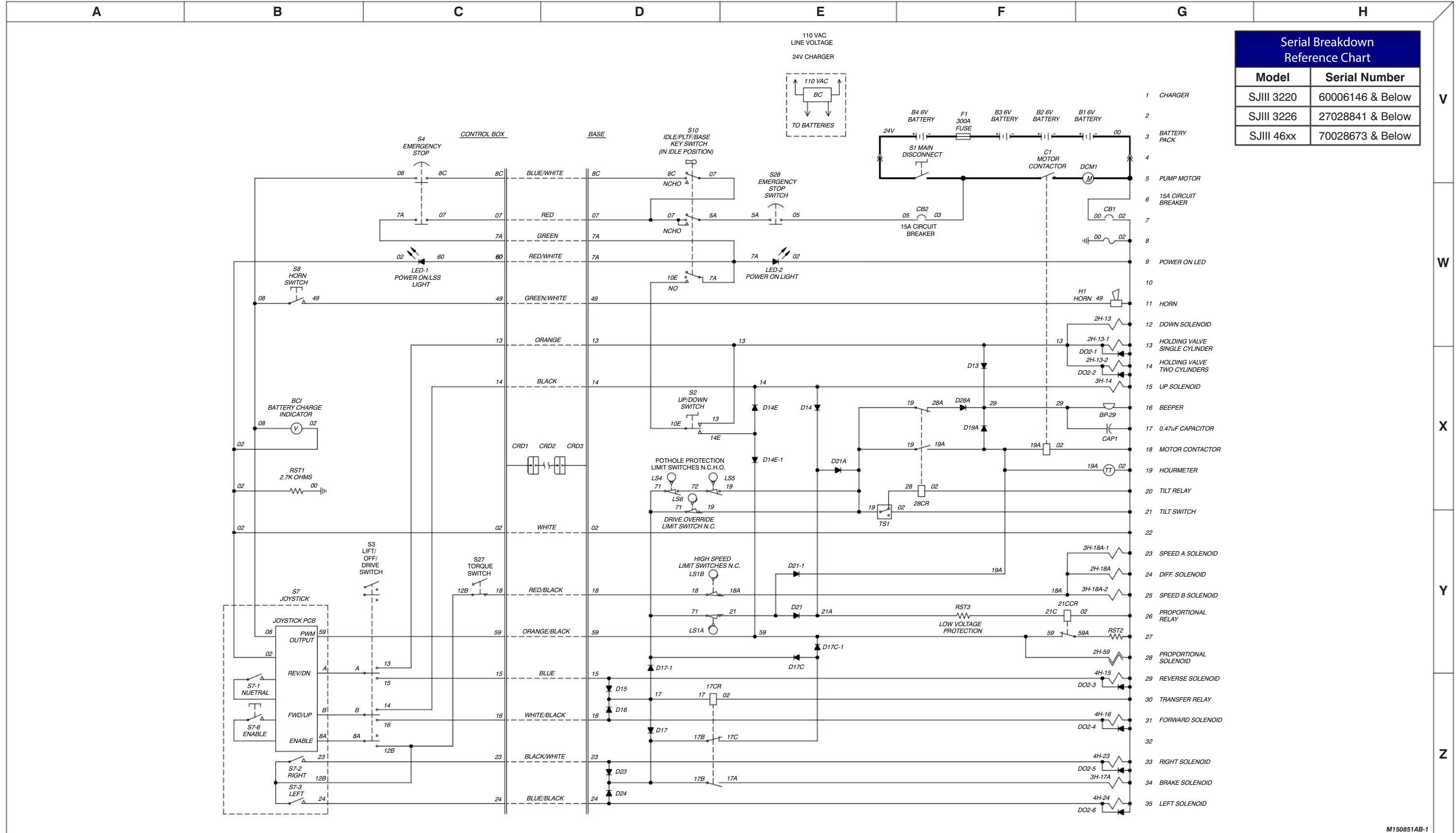

Serial Breakdown Reference Chart	
Model	Serial Number
SJIII 3220	60006146 & Below
SJIII 3226	27028841 & Below
SJIII 46xx	70028673 & Below

- 1 CHARGER
- 2
- 3 BATTERY PACK
- 4
- 5 PUMP MOTOR
- 6 15A CIRCUIT BREAKER
- 7
- 8
- 9 POWER ON LED
- 10
- 11 HORN
- 12 DOWN SOLENOID
- 13 HOLDING VALVE SINGLE CYLINDER
- 14 HOLDING VALVE TWO CYLINDERS
- 15 UP SOLENOID
- 16 BEEPER
- 17 0.47uF CAPACITOR
- 18 MOTOR CONTACTOR
- 19 HOURMETER
- 20 TILT RELAY
- 21 TILT SWITCH
- 22
- 23 SPEED A SOLENOID
- 24 DIFF. SOLENOID
- 25 SPEED B SOLENOID
- 26 PROPORTIONAL RELAY
- 27
- 28 PROPORTIONAL SOLENOID
- 29 REVERSE SOLENOID
- 30 TRANSFER RELAY
- 31 FORWARD SOLENOID
- 32
- 33 RIGHT SOLENOID
- 34 BRAKE SOLENOID
- 35 LEFT SOLENOID

M150851AB-1

3.29c Electrical Schematic (EE Rated - Equipped with no options)

AK

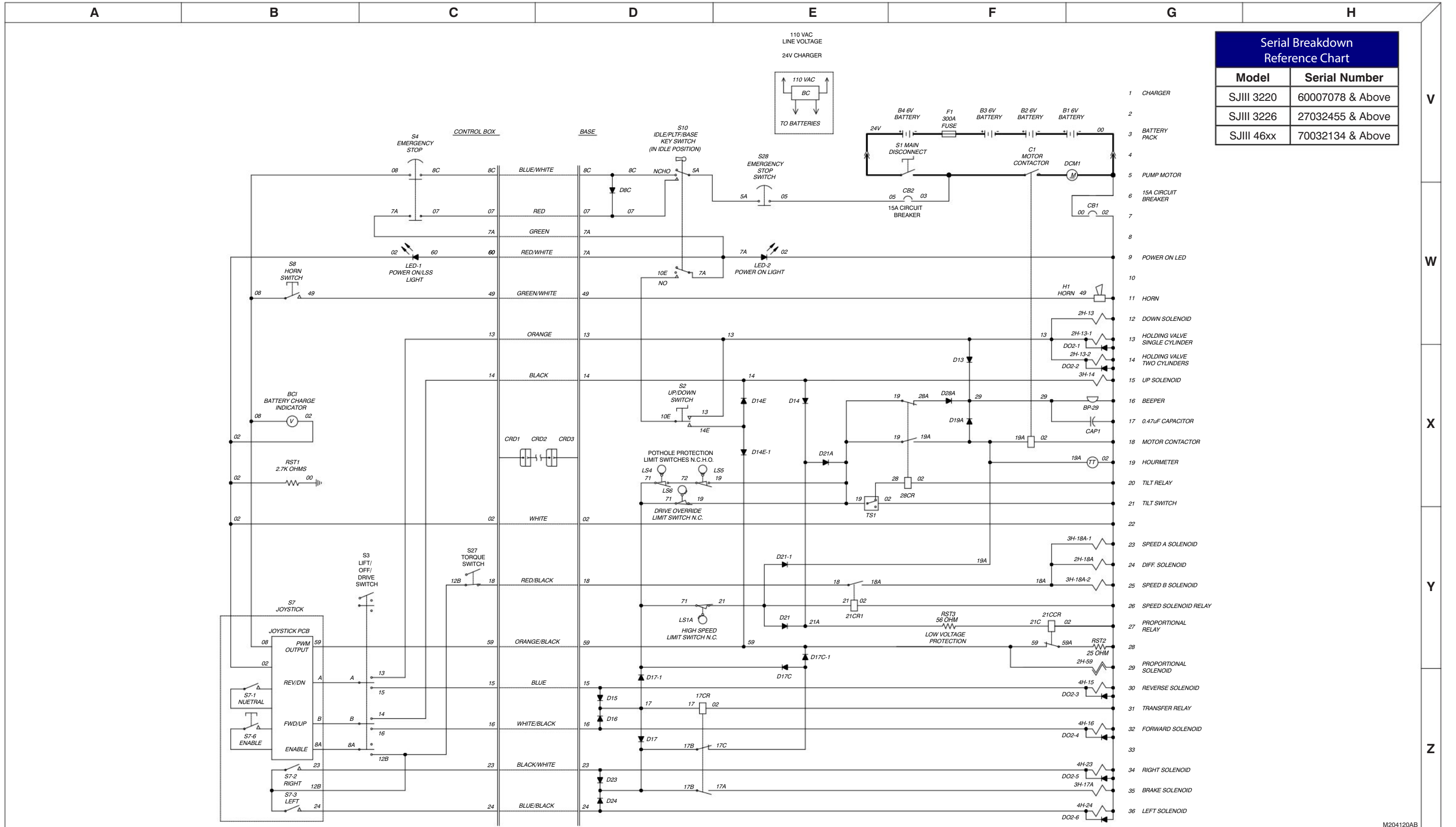

Serial Breakdown Reference Chart	
Model	Serial Number
SJIII 3220	60007078 & Above
SJIII 3226	27032455 & Above
SJIII 46xx	70032134 & Above

- 1 CHARGER
- 2 BATTERY PACK
- 3 BATTERY PACK
- 4 PUMP MOTOR
- 5 15A CIRCUIT BREAKER
- 6 POWER ON LED
- 7 HORN
- 8 DOWN SOLENOID
- 9 HOLDING VALVE SINGLE CYLINDER
- 10 HOLDING VALVE TWO CYLINDERS
- 11 UP SOLENOID
- 12 BEEPER
- 13 0.47UF CAPACITOR
- 14 MOTOR CONTACTOR
- 15 HOURMETER
- 16 TILT RELAY
- 17 TILT SWITCH
- 18 SPEED A SOLENOID
- 19 DIFF. SOLENOID
- 20 SPEED B SOLENOID
- 21 SPEED SOLENOID RELAY
- 22 PROPORTIONAL RELAY
- 23 PROPORTIONAL SOLENOID
- 24 REVERSE SOLENOID
- 25 TRANSFER RELAY
- 26 FORWARD SOLENOID
- 27 RIGHT SOLENOID
- 28 BRAKE SOLENOID
- 29 LEFT SOLENOID

W

X

Y

Z

M204120AB

3.30a Electrical Schematic (All Models - Equipped with all options)

AI

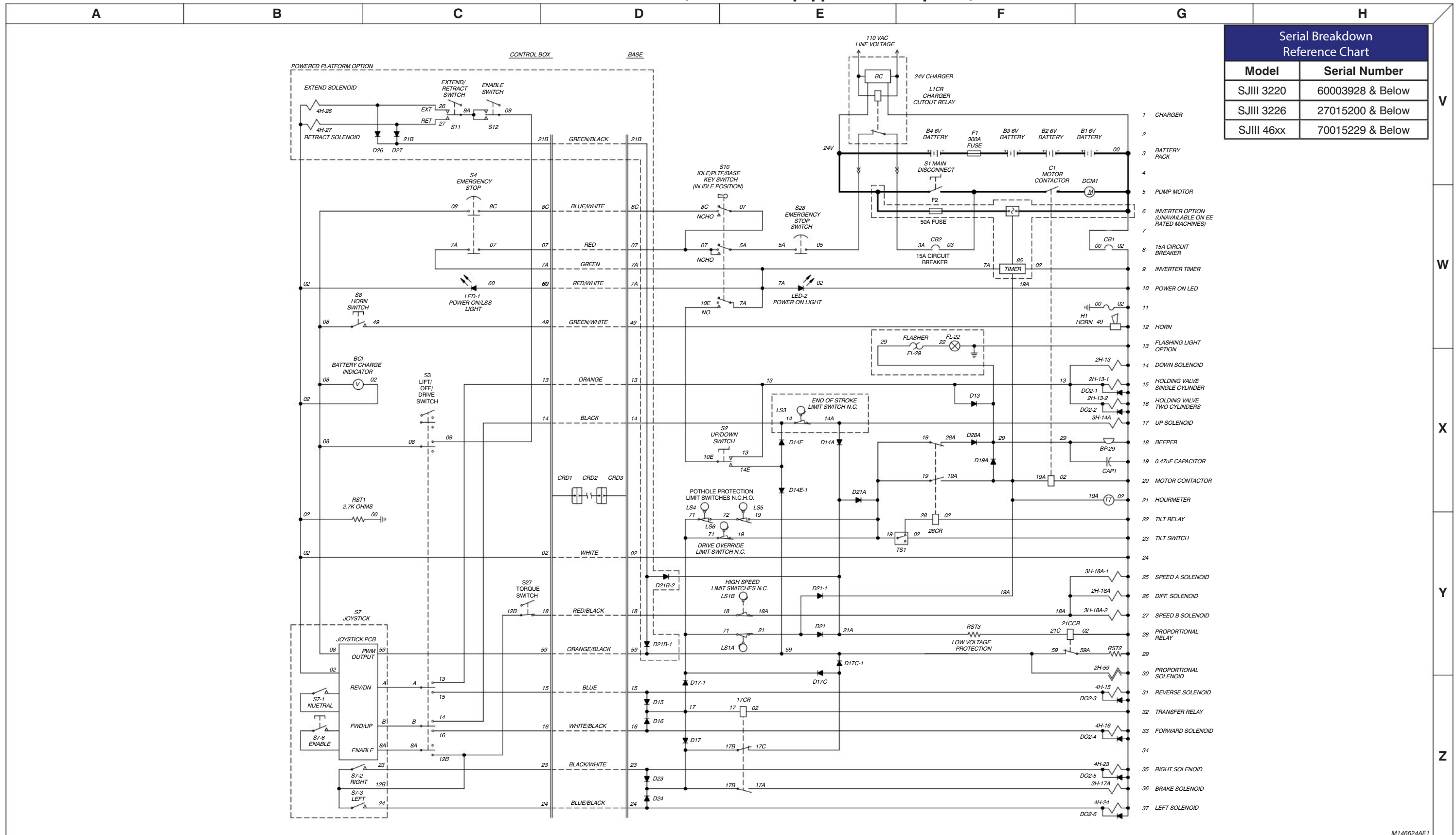

Serial Breakdown Reference Chart	
Model	Serial Number
SJIII 3220	60003928 & Below
SJIII 3226	27015200 & Below
SJIII 46xx	70015229 & Below

V

W

X

Y

Z

M146624AE1

3.30b Electrical Schematic (All Models - Equipped with all options)

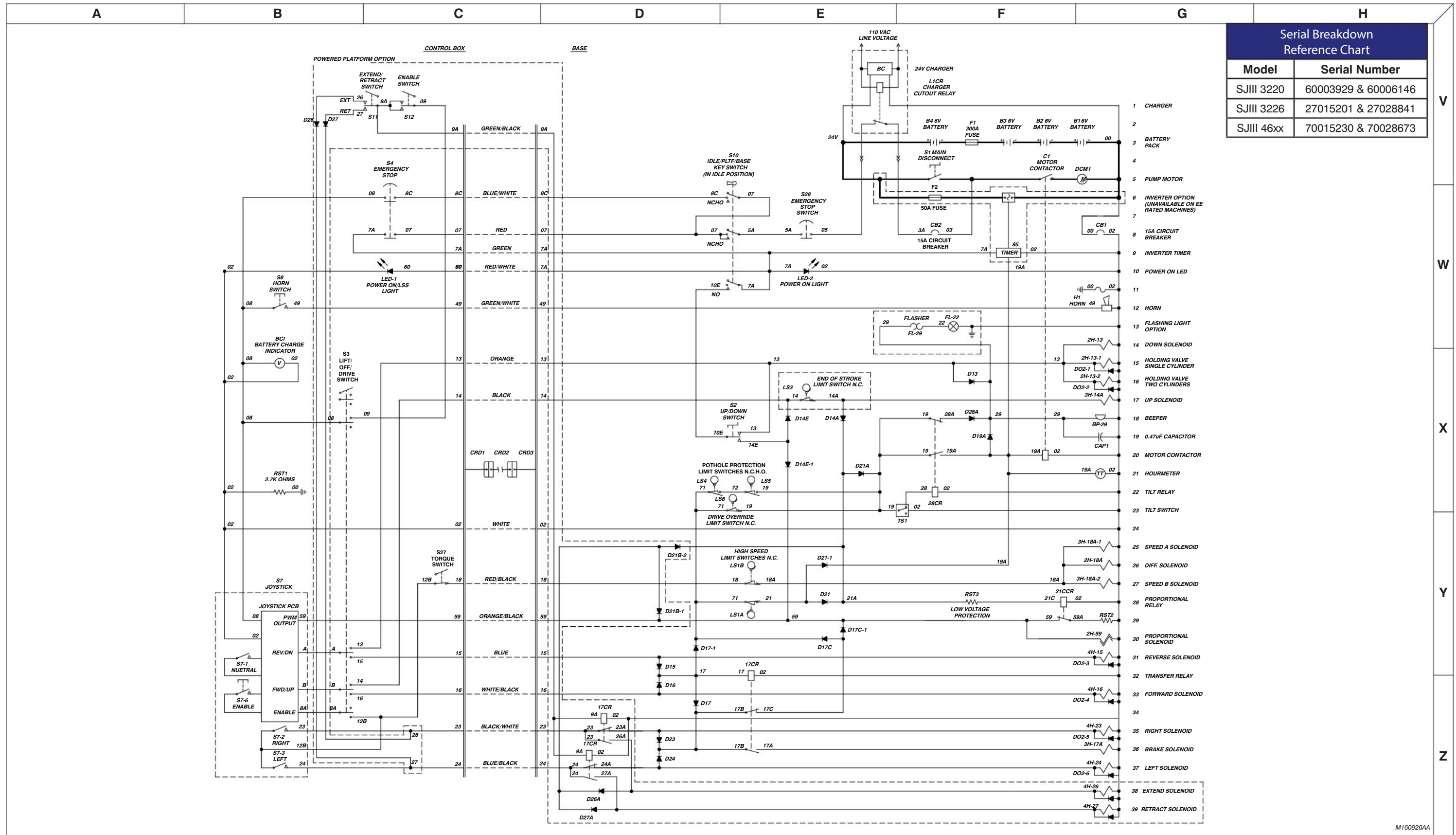

Serial Breakdown Reference Chart	
Model	Serial Number
SJIII 3220	60003929 & 60006146
SJIII 3226	27015201 & 27028841
SJIII 46xx	70015230 & 70028673

- 1 CHARGER
- 2 BATTERY PACK
- 3 PUMP MOTOR
- 4 INVERTER OPTION (UNAVAILABLE ON E-E RATED MACHINES)
- 5 15A CIRCUIT BREAKER
- 6 INVERTER TIMER
- 7 POWER ON LED
- 8 HORN
- 9 FLASHING LIGHT OPTION
- 10 DOWN SOLENOID
- 11 HOLDING VALVE SINGLE CYLINDER
- 12 HOLDING VALVE TWO CYLINDERS
- 13 UP SOLENOID
- 14 BEEPER
- 15 0.47UF CAPACITOR
- 16 MOTOR CONTACTOR
- 17 HOURMETER
- 18 TILT RELAY
- 19 TILT SWITCH
- 20 SPEED A SOLENOID
- 21 DIFF SOLENOID
- 22 SPEED B SOLENOID
- 23 PROPORTIONAL RELAY
- 24 PROPORTIONAL SOLENOID
- 25 REVERSE SOLENOID
- 26 TRANSFER RELAY
- 27 FORWARD SOLENOID
- 28 RIGHT SOLENOID
- 29 BRAKE SOLENOID
- 30 LEFT SOLENOID
- 31 EXTEND SOLENOID
- 32 RETRACT SOLENOID

3.30c Electrical Schematic (All Models - Equipped with all options)

AI

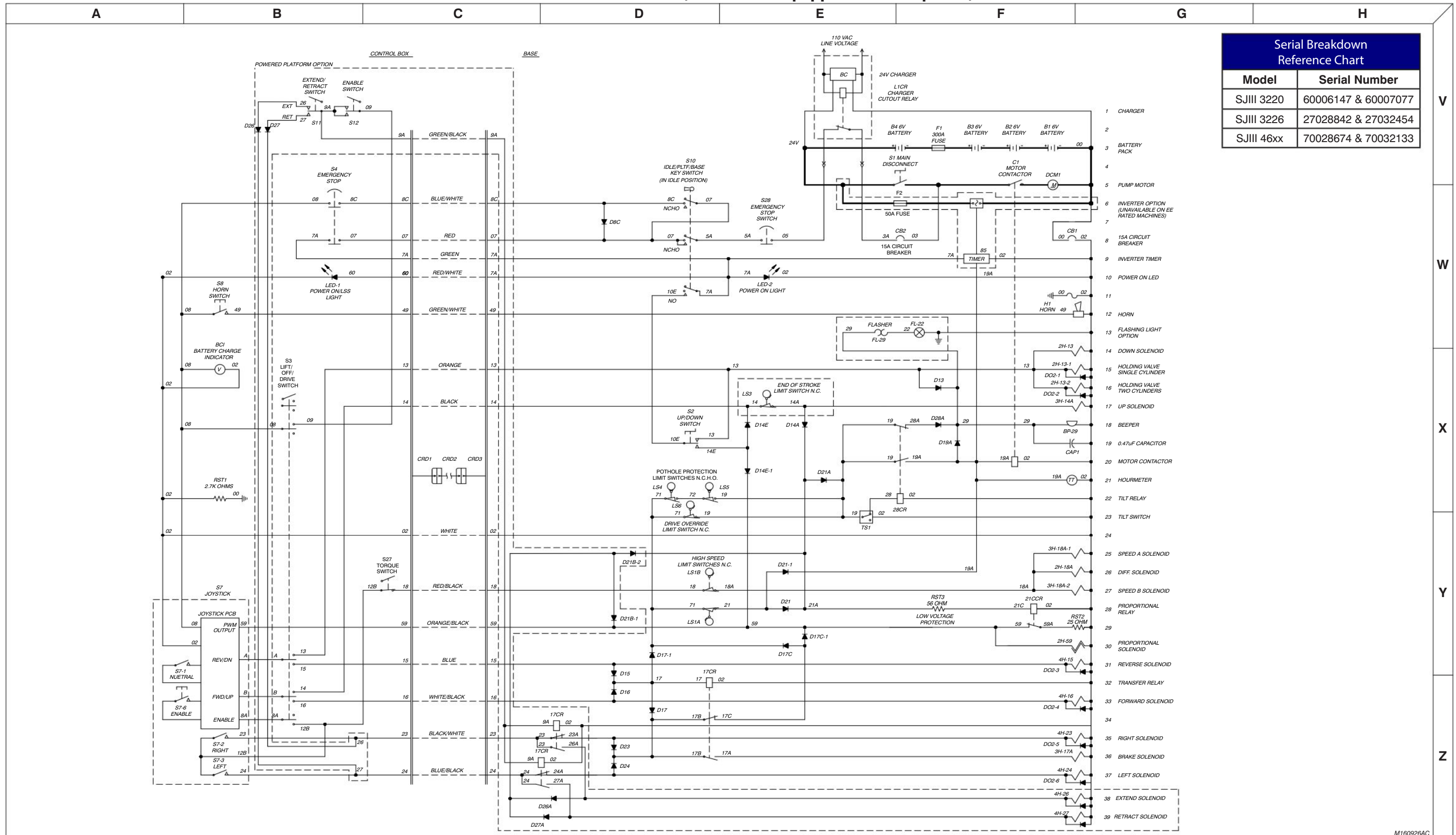

Serial Breakdown Reference Chart	
Model	Serial Number
SJIII 3220	60006147 & 60007077
SJIII 3226	27028842 & 27032454
SJIII 46xx	70028674 & 70032133

V

W

X

Y

Z

3.30d Electrical Schematic (All Models - Equipped with all options) - EE-Rated

AK

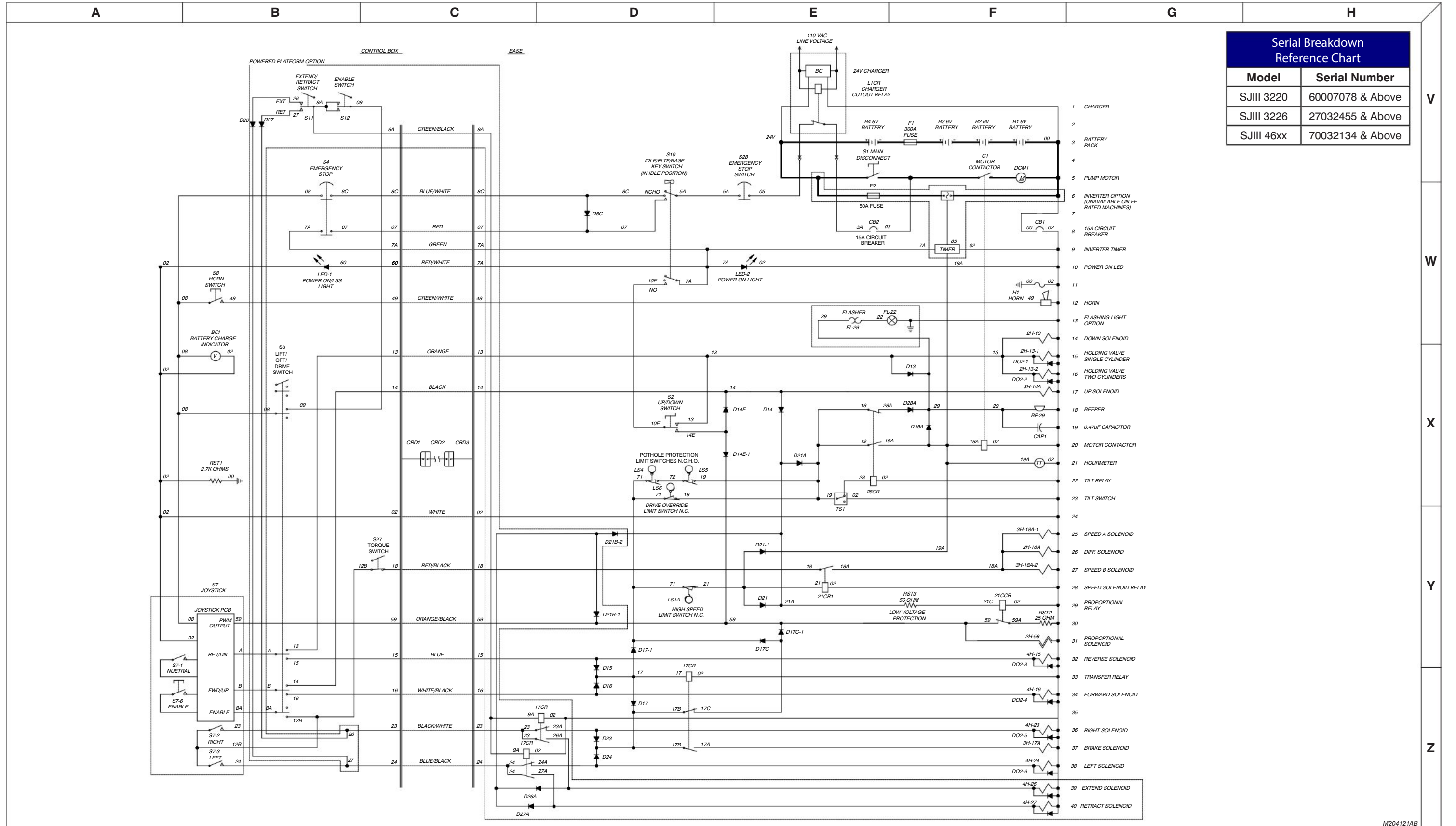

Serial Breakdown Reference Chart	
Model	Serial Number
SJIII 3220	60007078 & Above
SJIII 3226	27032455 & Above
SJIII 46xx	70032134 & Above

V

W

X

Y

Z

Section 4 - TROUBLESHOOTING INFORMATION

Introduction.....	96
-------------------	----

Electrical System

4.1-1 All Controls Inoperative.....	97
4.1-2 All Controls Except for Down Function Inoperative.....	97
4.1-3 All Controls Inoperative From Base Control Console.....	98
4.1-4 All Controls Inoperative From Platform Control Console.....	98
4.1-5 No Drive or Up Function from Platform or Base Controls (CE only).....	99
4.1-6 No Down or Reverse Only Function from Platform Controls.....	99
4.1-7 No Up or Forward Only Function from Platform Control Console.....	99
4.1-8 No Up Function from Platform or Base Control Console.....	99
4.1-9 No Down Function from Platform or Base Control Console (ANSI/CSA).....	100
4.1-10 No Down Function from Platform or Base Control Console (CE).....	100
4.1-11 No Up Function from Base Control Console.....	101
4.1-12 No Down Function from Base Control Console.....	101
4.1-13 Steer Only Inoperative.....	101
4.1-14 Drive Only Inoperative.....	101
4.1-15 No Drive or Steer when Platform Fully Lowered.....	101
4.1-16 No Drive or Steer when Platform Elevated.....	102
4.1-17 Elevated Drive Speed Does not Activate.....	102
4.1-18 Work Platform Drives in Slow Speed Only.....	102
4.1-19 Forward Drive Function Inoperative.....	103
4.1-20 Reverse Drive Function Inoperative.....	103
4.1-21 Brake will not Release.....	103
4.1-22 High/Low Torque Inoperative.....	103
4.1-23 Right Steer Inoperative.....	104
4.1-24 Left Steer Inoperative.....	104
4.1-25 Power Extension Platform will not Extend or Retract.....	105
4.1-26 Power Extension Platform will not Extend.....	105
4.1-27 Power Extension Platform will not Retract.....	105
4.1-28 Two or more Functions at one time.....	105

Hydraulic Systems

4.2-1 All Function Inoperative.....	106
4.2-2 Platform Drifts Down.....	106
4.2-3 Platform Lifts Slowly.....	106
4.2-4 Platform does not Lift.....	106
4.2-5 Platform will not Lower.....	106
4.2-6 Platform Drives Slow.....	107
4.2-7 Platform will not Drive in Forward or Reverse.....	107
4.2-8 Brake(s) will not Release.....	107
4.2-9 Brake(s) will not Release (Additional for machines with Integral Brakes).....	107
4.2-10 Aerial Platform will not hold on a Grade (Machines with Integrals Brakes).....	108
4.2-11 Platform does not Steer.....	108
4.2-12 All System sluggish.....	108
4.2-13 Power Extension Platform will not Extend or Retract.....	108
4.2-14 High/Low Torque Inoperative.....	108

Introduction

The following pages contain a table of Troubleshooting Information for locating and correcting most service trouble which can develop. Careful and accurate analysis of the systems listed in the table of Troubleshooting Information will localize the trouble more quickly than any other method. This manual cannot cover all possible troubles and deficiencies that may occur. If a specific trouble is not listed, isolate the major component in which the trouble occurs, isolate whether the problem is electrical or hydraulic, and then isolate and correct the specific problem.

The content of this section is separated into “probable cause” and “remedy.” The information preceded by a number represents the “probable cause.” The following line, noted by a dash represents the “remedy” to the “probable cause” directly above it. See example below for clarification.

1. Probable Cause
 - Remedy

Electrical System

4.1-1 All Controls Inoperative

1. Battery Charger plugged into external power source.
 - Disconnect charger cord.
2. Batteries disconnected.
 - Connect batteries.
3. Dirty or loose battery terminals.
 - Clean and tighten connections.
4. Battery charge low.
 - Check each cell with hydrometer. Reading should be 1.275 (fully charged). Recharge if low reading. Replace if reading difference between cells is 0.050.
5. Main battery cables open or defective.
 - Check continuity. Replace if defective.
6. Fuse F1 defective.
 - Replace fuse.
7. Main battery disconnect switch S1 open or defective.
 - Close switch. Check continuity. Replace if defective.
8. Loose or broken wire #3 from motor contactor C1 to circuit breaker CB2.
 - Check continuity. Replace if defective.
9. Loose or broken wire #3A from circuit breaker CB2 to charger relay L1CR.
 - Check continuity. Replace if defective.
10. Defective battery charger relay L1CR.
 - Check relay. Replace if defective.
11. Defective or tripped circuit breaker CB2.
 - Reset circuit breaker. Replace if defective.
12. Loose or broken wire #5 from charger relay L1CR to base terminal block TB-1.
 - Check continuity. Replace if defective.
13. Loose or broken wire #5 from base terminal block TB-1 to base emergency stop switch S28.
 - Check continuity. Replace if defective.
14. Open or defective base emergency stop switch S28.
 - Close switch. Check switch. Replace if defective.
15. Loose or broken wire #5A from base emergency stop switch S28 to base key switch S10.
 - Check continuity. Replace if defective.
16. Open or defective base key switch S10.
 - Select function with switch. Check switch. Replace if defective.
17. Loose or broken wire #00 from pump motor DCM1 to circuit breaker CB1.
 - Check continuity. Replace if defective.
18. Defective or tripped circuit breaker CB1.
 - Reset circuit breaker. Replace if defective.
19. Loose or broken wire #2 from circuit breaker CB1 to base terminal block TB-1.
 - Check continuity. Replace if defective.
20. Loose or broken wire #7A from base terminal block to CM1 control module pin P2-12. **(CE)**
 - Check continuity. Replace if defective.
21. Loose or broken wire #02 from base terminal block to CM1 control module pin P2-11. **(CE)**
 - Check continuity. Replace if defective.

4.1-2 All Controls Except for Down Function Inoperative

1. Loose or broken wire #19A **(ANSI/CSA)** or wire #19B **(CE)** from base terminal block TB-1 to contactor C1.
 - Check continuity. Replace if defective.

Electrical System (Continued)

2. Contactor C1 defective.
 - Check contactor. Replace if defective.
3. Defective pump motor DCM1.
 - Check motor. Replace if defective.
4. Loose or broken wire #59 from relay 21CCR (ANSI/CSA) or relay 21ACR (CE) to proportional valve coil 2H-59.
 - Check continuity. Replace if defective.
5. Loose or broken wire #02 from proportional valve coil 2H-59 to base terminal block TB-1.
 - Check continuity. Replace if defective.
6. Defective proportional valve coil 2H-59.
 - Check continuity through coil. Reading should be 19ohms. Replace if defective.

4.1-3 All Controls Inoperative From Base Control Console

1. Loose or broken wire #07 from base terminal block to platform emergency stop switch S4.
 - Check continuity. Replace if defective.
2. Open or defective platform emergency stop switch S4.
 - Close switch. Replace if defective.
3. Loose or broken wire #7A from platform emergency stop switch S4 to base terminal block.
 - Check continuity. Replace if defective.
4. Loose or broken wire #7A from base terminal block to base key switch S10.
 - Check continuity. Replace if defective.
5. Open or defective base key switch S10.
 - Close switch. Replace if defective.
6. Loose or broken wire #10E from base key switch S10 to base up/down switch S2.
 - Check continuity. Replace if defective.
7. Loose or broken wire #10E from base terminal block TB-1 to CM1 control module pin P2-2. (CE)
 - Check continuity. Replace if defective.

4.1-4 All Controls Inoperative From Platform Control Console

1. Loose or broken wire #8C from base key switch S10 to base terminal block.
 - Check continuity. Replace if defective.
2. Loose or broken wire #8C or wire #02 from base terminal block to platform emergency stop switch S4.
 - Check continuity. Replace if defective.
3. Open or defective platform emergency stop switch S4.
 - Close switch. Replace if defective.
4. Loose or broken wire #8 or wire #02 from emergency stop switch S4 to battery charge indicator BCI.
 - Check continuity. Replace if defective.
5. Loose or broken wire #8 or wire #02 from battery charge indicator BC1 to joystick S7.
 - Check continuity. Replace if defective.
6. Defective joystick enable switch S7-6.
 - Check switch. Replace if defective.
7. Defective joystick neutral switch S7-1.
 - Check switch. Replace if defective.
8. Defective joystick S7.
 - Check joystick. Replace if defective.

Electrical System (Continued)**4.1-5 No Drive or Up Function from Platform or Base Controls (CE only)**

1. Defective tilt relay 28CR1 or Aux. tilt relay 28ECR1.
 - Check relay. Replace if defective.
2. Loose or broken wire #02 from base terminal block to tilt relay 28CR1 or Aux. tilt relay 28ECR1.
 - Check continuity. Replace if defective.
3. Loose or broken wire #28 from CM1 control module pin P3-4 to tilt relay 28CR1.
 - Check continuity. Replace if defective.
4. Loose or broken wire #28E from CM1 control module pin P3-6 to Aux. tilt relay 28ECR1.
 - Check continuity. Replace if defective.
5. Loose or broken wire #19 from base terminal block to Aux. tilt relay 28ECR1.
 - Check continuity. Replace if defective.
6. Loose or broken wire #19A from Aux. tilt relay 28ECR1 to tilt relay 28CR1.
 - Check continuity. Replace if defective.
7. Loose or broken wire #19B from tilt relay 28CR1 to base terminal block.
 - Check continuity. Replace if defective.
8. Loose or broken wire #19B from base terminal block to motor contactor C1.
 - Check continuity. Replace if defective.

4.1-6 No Down or Reverse Only Function from Platform Controls

1. Loose or broken wire "A" from proportional controller S7 to lift/drive switch S3.
 - Check continuity. Replace if defective.
2. Lift/Drive switch S3 defective.
 - Check switch. Replace if defective.
3. Defective PWM card on joystick S7.
 - Check joystick card. Replace if defective.
4. Loose or broken wire #13 down or #15 reverse from lift/drive switch S3 to base terminal block.
 - Check continuity. Replace if defective.

4.1-7 No Up or Forward Only Function from Platform Control Console

1. Loose or broken wire "B" from proportional controller S7 to lift/drive switch S3.
 - Check continuity. Replace if defective.
2. Lift/Drive switch S3 defective.
 - Check switch. Replace if defective.
3. Defective PWM card on joystick S7.
 - Check joystick card. Replace if defective.
4. Loose or broken wire #14 up or #16 forward from lift/drive switch S3 to base terminal block.
 - Check continuity. Replace if defective.

4.1-8 No Up Function from Platform or Base Control Console

1. Loose or broken wire #14 from base terminal block to up valve coil 3H-14.
 - Check continuity. Replace if defective.
2. Defective up valve coil 3H-14.
 - Check continuity through coil. Replace if defective.
3. Open diode D14.
 - Check diode. Replace if defective.
4. Open diode D21A (ANSI/CSA) or D21 (CE).
 - Check diode. Replace if defective.
5. Machine not level. (Above high speed limit switch)
 - Use on level surface.

Electrical System (Continued)

6. Loose or broken wire #19 from base terminal block to tilt switch TS1 **(ANSI/CSA)**.
 - Check continuity. Replace if defective.
7. Defective tilt switch TS1 **(ANSI/CSA)**.
 - Test tilt switch. Replace if defective.
8. Loose or broken wire #28 from tilt switch TS1 to tilt relay 28CR **(ANSI/CSA)**.
 - Check continuity. Replace if defective.
9. Loose or broken wire #02 from tilt switch TS1 to base terminal strip **(ANSI/CSA)**.
 - Check continuity. Replace if defective.
10. Defective tilt relay 28CR **(ANSI/CSA)**.
 - Check relay. Replace if defective.
11. Loose or broken wire #19A from tilt relay 28CR to pump motor contactor **(ANSI/CSA)**.
 - Check continuity. Replace if defective.
12. See 4.1-5 of this section for more troubleshooting information for **(CE)**.

4.1-9 No Down Function from Platform or Base Control Console (ANSI/CSA)**NOTE**

Down function is not proportionally controlled.

1. Loose or broken wire #13 from base terminal block to down valve 2H-13 or holding valve 2H-13-1 or holding valve 2H-13-2.
 - Check continuity. Replace if defective.
2. Loose or broken wire #02 from base terminal block to down valve 2H-13 or holding valve 2H-13-1 or holding valve 2H-13-2.
 - Check continuity. Replace if defective.
3. Defective down valve 2H-13.
 - Check continuity through coil. Replace if defective.
4. Defective lift cylinder holding valve 2H-13-1 or holding valve 2H-13-2.
 - Check continuity through coil. Replace if defective.

4.1-10 No Down Function from Platform or Base Control Console (CE)**NOTE**

Down function is not proportionally controlled.

1. Loose or broken wire #13 from base terminal block to CM1 control module pin P2-4.
 - Check continuity. Replace if defective.
2. Defective down relay 28CR2 or Aux. down relay 28ECR2.
 - Check relay. Replace if defective.
3. Loose or broken wire #02 from base terminal block to down relay 28CR2 or Aux. down relay 28ECR2.
 - Check continuity. Replace if defective.
4. Loose or broken wire #13 from base terminal block to Aux. down relay 28ECR2.
 - Check continuity. Replace if defective.
5. Loose or broken wire #13A from Aux. down relay 28ECR2 to down relay 28CR2.
 - Check continuity. Replace if defective.
6. Loose or broken wire # 13B from down relay 28CR2 to down valve 2H-13B or holding valve 2H-13B-1 or holding valve 2H-13B-2.
 - Check continuity. Replace if defective.
7. Defective down valve 2H-13B.

Electrical System (Continued)

- Check continuity through coil. Replace if defective.
- 8. Defective lift cylinder holding valve 2H-13B-1 or holding valve 2H-13B-2.
 - Check continuity through coil. Replace if defective.
- 9. Loose or broken wire #02 from holding valve 2H-13B-1 or holding valve 2H-13B-2 or down valve 2H-13B to base terminal block.
 - Check continuity. Replace if defective.

4.1-11 No Up Function from Base Control Console

1. Defective up/down switch S2.
 - Check switch. Replace if defective.
2. Loose or broken wire #14E from up/down switch S2 to base terminal switch.
 - Check continuity. Replace if defective.
3. Open diode D14E-1.
 - Check diode. Replace if defective.
4. Open diode D14E (ANSI/CSA) or diode D14E-2 (CE).
 - Check diode. Replace if defective.

4.1-12 No Down Function from Base Control Console

1. Defective up/down switch S2.
 - Check switch. Replace if defective.
2. Loose or broken wire #13 from up/down switch S2 to base terminal block.
 - Check continuity. Replace if defective.

4.1-13 Steer Only Inoperative

1. Defective relay 17CR.
 - Check relay. Replace if defective.
2. Loose or broken wire #17B from diodes D23 and D24 to base terminal block TB1.
 - Check continuity. Replace if defective.
3. Loose or broken wire #17B from 17CR steer relay to base terminal block TB1.
 - Check continuity. Replace if defective.
4. Loose or broken wire #17C from 17CR steer relay to diodes D17C and D17C-1.
 - Check continuity. Replace if defective.
5. Open or defective diode D17C or diode D17C-1.
 - Check diode. Replace if defective.

4.1-14 Drive Only Inoperative

1. Open or defective diode D17-1.
 - Check diode. Replace if defective.

4.1-15 No Drive or Steer when Platform Fully Lowered

1. Loose or broken wire #71 from base terminal block to drive override limit switch LS6.
 - Check continuity. Replace if defective.
2. Defective drive override switch LS6.
 - Check switch. Replace if defective.
3. Loose or broken wire #19 from drive override limit switch LS6 to base terminal block.
 - Check continuity. Replace if defective.

Electrical System (Continued)**4.1-16 No Drive or Steer when Platform Elevated**

1. Pothole protection bars not fully lowered.
 - Clear obstructions. Repair as needed.
2. Loose or broken wire #71 from base terminal block to pothole protection limit switch LS4.
 - Check continuity. Replace if defective.
3. Defective pothole protection limit switch LS4.
 - Check switch. Replace if defective.
4. Loose or broken wire #72 from pothole protection limit switch LS4 to base terminal block.
 - Check continuity. Replace if defective.
5. Loose or broken wire #72 from base terminal block to pothole protection limit switch LS5.
 - Check continuity. Replace if defective.
6. Defective pothole protection limit switch LS5.
 - Check switch. Replace if defective.
7. Loose or broken wire #19 from pothole protection limit switch LS5 to base terminal block.
 - Check continuity. Replace if defective.

4.1-17 Elevated Drive Speed Does not Activate

1. Loose or broken wire #59 from base terminal strip proportional relay 21CCR (ANSI/CSA) or 21ACR (CE).
 - Check continuity. Replace if defective.
1. Loose or broken wire #59A from proportional relay 21CCR (ANSI/CSA) or 21ACR (CE) to resistor RST2.
 - Check continuity. Replace if defective.
2. Resistor RST2 open.
 - Check resistor ohms, it should be 30 ohms. Replace if defective.
3. Loose or broken wire #02 from resistor RST2 to base terminal block.
 - Check continuity. Replace if defective.
4. Proportional relay 21CCR (ANSI/CSA) or 21ACR (CE) defective.
 - Check relay, replace if defective.

4.1-18 Work Platform Drives in Slow Speed Only

1. Loose or broken wire #71 from base terminal block to high speed limit switch LS1A.
 - Check continuity. Replace if defective.
2. Open or defective high speed limit switch LS1A.
 - Check switch. Replace if defective.
3. Loose or broken wire #21 from high speed limit switch LS1A to low voltage protection resistor RST3.
 - Check continuity. Replace if defective.
4. Defective low voltage protection resistor RST3.
 - Check resistor. Replace if defective.
5. Loose or broken wire #21C (ANSI/CSA) or #21A (CE) from low voltage protection resistor RST3 to proportional relay 21CCR (ANSI/CSA) or 21ACR (CE).
 - Check continuity. Replace if defective.
6. Proportional relay 21CCR (ANSI/CSA) or 21ACR (CE) defective.
 - Check relay, replace if defective.
7. Loose or broken wire #02 from proportional relay 21CCR (ANSI/CSA) or 21ACR (CE) to base terminal block.
 - Check continuity. Replace if defective.
8. Proportional controller S7 out of adjustment.
 - Adjust controller. Refer to Section 5, Joystick Adjusting Procedure.

Electrical System (Continued)**4.1-19 Forward Drive Function Inoperative**

1. Loose or broken wire #16 from lift/drive switch S3 to base terminal block.
 - Check continuity. Replace if defective.
2. Loose or broken wire #16 from base terminal block to forward drive valve coil 4H-16.
 - Check continuity. Replace if defective.
3. Forward drive valve coil 4H-16 defective.
 - Check continuity through coil. Replace if defective.
4. Loose or broken wire #02 from forward drive valve coil 4H-16 to base terminal block.
 - Check continuity. Replace if defective.
5. Open diode D16.
 - Check diode. Replace if defective.

4.1-20 Reverse Drive Function Inoperative

1. Loose or broken wire #15 from lift/drive switch S3 to base terminal block.
 - Check continuity. Replace if defective.
2. Loose or broken wire #15 from base terminal block to reverse drive valve coil 4H-15.
 - Check continuity. Replace if defective.
3. Reverse drive valve coil 4H-15 defective.
 - Check continuity through coil. Replace if defective.
4. Loose or broken wire #02 from reverse drive valve coil 4H-15 to base terminal block.
 - Check continuity. Replace if defective.
5. Open diode D15.
 - Check diode. Replace if defective.

4.1-21 Brake will not Release

1. Diode D-16 forward or D-15 reverse is shorted or open.
 - Check diode. Replace if defective.
2. Loose or broken wire #17 from base terminal strip to transfer relay 17CR.
 - Check continuity. Replace if defective.
3. Loose or broken wire #02 from base terminal strip to transfer relay 17CR.
 - Check continuity. Replace if defective.
4. Defective transfer relay 17CR.
 - Check relay. Replace if defective.
5. Open or defective diode D17.
 - Check diode. Replace if defective.
6. Loose or broken wire #17B from base terminal strip to transfer relay 17CR.
 - Check continuity. Replace if defective.
7. Loose or broken wire #17A from transfer relay 17CR to brake coil 3H-17A.
 - Check continuity. Replace if defective.
8. Brake valve coil 3H-17A defective.
 - Check continuity through coil. Replace if defective.
9. Loose or broken wire #02 from brake valve coil 3H-17A to base terminal block.
 - Check continuity. Replace if defective.

4.1-22 High/Low Torque Inoperative

1. Open diode D15-1 (reverse) or D16-1 (forward).
 - Check diode. Replace if defective.
2. Loose or broken wire #7B from diodes D15-1 and D16-1 to lift/drive switch S3.
 - Check continuity. Replace if defective.

Electrical System (Continued)

3. Defective lift/drive switch S3.
 - Check switch. Replace if defective.
4. Loose or broken wire #18 from lift/drive switch S3 to base terminal block TB-1.
 - Check continuity. Replace if defective.
5. Loose or broken wire #18 from base terminal block TB-1 to high speed limit switch LS1-B.
 - Check continuity. Replace if defective.
6. Defective high speed limit switch LS1-B.
 - Check switch. Replace if defective.
7. Loose or broken wire #18A from high speed limit switch LS1-B to rear drive manifold.
 - Check continuity. Replace if defective.
8. Defective speed valve coil 3H-18A-1 or 3H-18A-2.
 - Check continuity through coil. Replace if defective.
9. Loose or broken wire #02 from rear drive manifold to base terminal block TB-1.
 - Check continuity. Replace if defective.

4.1-23 Right Steer Inoperative

1. Loose or broken wire #12B from lift/drive switch S3 to right steer switch S7-2.
 - Check continuity. Replace if defective.
2. Defective right steer switch S7-2.
 - Check switch. Replace if defective.
3. Loose or broken wire #23 from right steer switch S7-2 to base terminal block TB-1.
 - Check continuity. Replace if defective.
4. Loose or broken wire #23 from base terminal block TB-1 to steer right valve coil 4H-23.
 - Check continuity. Replace if defective.
5. Defective steer right valve coil 4H-23.
 - Check continuity through coil. Replace if defective.
6. Loose or broken wire #02 from steer right valve coil 4H-23 to base terminal block TB-1.
 - Check continuity. Replace if defective.
7. Open diode D23.
 - Check diode. Replace if defective.

4.1-24 Left Steer Inoperative

1. Loose or broken wire #12B from lift/drive switch S3 to left steer switch S7-3.
 - Check continuity. Replace if defective.
2. Defective left steer switch S7-3.
 - Check switch. Replace if defective.
3. Loose or broken wire #24 from left steer switch S7-3 to base terminal block TB-1.
 - Check continuity. Replace if defective.
4. Loose or broken wire #24 from base terminal block TB-1 to steer left valve coil 4H-24.
 - Check continuity. Replace if defective.
5. Defective steer left valve coil 4H-24.
 - Check continuity through coil. Replace if defective.
6. Loose or broken wire #02 from steer left valve coil 4H-24 to base terminal block TB-1.
 - Check continuity. Replace if defective.
7. Open diode D24.
 - Check diode. Replace if defective.

Electrical System (Continued)**4.1-25 Power Extension Platform will not Extend or Retract**

1. Lift/Drive switch S3 not in lift position.
 - [Move switch to lift position.](#)
2. Loose or broken wire #09 from lift/drive switch S3 to power extension platform enable switch S12.
 - [Check continuity. Replace if defective.](#)
3. Power extension platform enable switch S12 defective.
 - [Check switch. Replace if defective.](#)
4. Loose or broken wire #09A from power extension platform enable switch S12 to platform extend/retract switch S11.
 - [Check continuity. Replace if defective.](#)
5. Loose or broken wire #21B from platform control box to base terminal block TB-1.
 - [Check continuity. Replace if defective.](#)
6. Open diode D21B-1.
 - [Check diode. Replace if defective.](#)
7. Open diode D21B-2.
 - [Check diode. Replace if defective.](#)
8. Loose or broken wire #02 from extend valve coil 4H-26 to retract valve coil 4H-27 to platform control box.
 - [Check continuity. Replace if defective.](#)

4.1-26 Power Extension Platform will not Extend

1. Powered extension platform extend/retract switch S11 defective.
 - [Check switch. Replace if defective.](#)
2. Loose or broken wire #26 from power extension platform extend/retract switch S11 to extend valve coil 4H-26.
 - [Check continuity. Replace if defective.](#)
3. Extend valve coil 4H-26 defective.
 - [Check continuity through coil, replace if defective.](#)
4. Open diode D26.
 - [Check diode. Replace if defective.](#)
5. Loose or broken wire #02 from extend valve coil 4H-26 to platform control box.
 - [Check continuity. Replace if defective.](#)

4.1-27 Power Extension Platform will not Retract

1. Powered Platform extend/retract switch S11 defective.
 - [Check switch. Replace if defective.](#)
2. Loose or broken wire #27 from power extension platform extend/retract switch S11 to retract valve coil 4H-27.
 - [Check continuity. Replace if defective.](#)
3. Retract valve coil 4H-27 defective.
 - [Check continuity through coil, replace if defective.](#)
4. Open diode D27.
 - [Check diode. Replace if defective.](#)
5. Loose or broken wire #02 from retract valve coil 4H-27 to platform control box.
 - [Check continuity. Replace if defective.](#)

4.1-28 Two or more Functions at one time

1. Shorted Diode.
 - [Check continuity of all diodes. Replace if defective.](#)

Hydraulic System

4.2-1 All Function Inoperative

1. Proportional valve 2H-59 defective or is sticking.
 - Check valve. Replace if defective.
2. Pump P1 defective.
 - Check pump. Replace if defective.

4.2-2 Platform Drifts Down

1. Defective lift cylinder seals at the gland or holding valve manifold.
 - Replace if damaged. Note: There are no piston seals, just wear rings.
2. Combination of defective holding valves 2H-13-1 and 2H-13-2, and either defective lowering valve 2H-13 or relief valve R2 or manual lowering valve V1. **(ANSI/CSA)**
 - Check valves. Replace if defective.
 Combination of defective holding valves 2H-13B-1 and 2H-13B-2, and either defective lowering valve 2H-13B or relief valve R2 or manual lowering valve V1. **(CE)**
 - Check valves. Replace if defective.

4.2-3 Platform Lifts Slowly

1. Open or leaking manual lowering valve V1.
 - Close valve. Replace if defective.
2. Lift relief valve R2 defective.
 - Check valve. Replace if defective.
3. Open manual override on holding valve 2H-13-1 or 2H-13-2. **(ANSI/CSA)**
 - Depress and turn manual override clockwise to close. Replace if defective.
 Open manual override on holding valve 2H-13B-1 or 2H-13B-2. **(CE)**
 - Depress and turn manual override clockwise to close. Replace if defective.

4.2-4 Platform does not Lift

1. Open manual lowering valve V1.
 - Close valve. Replace if defective.
2. Hydraulic oil level too low.
 - Fully lower the platform. Fill hydraulic tank until fluid is at or slightly above the top mark on the sight glass.
3. Platform weight excessive.
 - Reduce platform load to maximum capacity.
4. Up valve 3H-14 or 3H-14A (Machines with end of stroke limit switch LS3 only) defective or is sticking.
 - Check valve. Replace if defective.

4.2-5 Platform will not Lower

NOTE

Down function is not proportionally controlled.

ANSI/CSA Machines only

1. Lowering valve 2H-13 defective or is sticking.
 - Clean valve. Replace if defective.
2. Defective holding valve 2H-13-1 or 2H-13-2.
 - Clean valve. Replace if defective.

Hydraulic System (Continued)**CE Machines only**

3. Lowering valve 2H-13 defective or is sticking.
 - Clean valve. Replace if defective.
4. Defective holding valve 2H-13B-1 or 2H-13B-2.
 - Clean valve. Replace if defective.

4.2-6 Platform Drives Slow

1. Free-wheeling valve V2 open or defective.
 - Close valve. Replace if defective.
2. Flow divider/combiner FD1 defective or is plugged.
 - Close valve. Replace if defective.
3. Drive motor M1 or M2 defective.
 - Check motors. Replace if defective.
4. Cushion cylinder C1 defective.
 - Check cylinder. Replace if defective.

4.2-7 Platform will not Drive in Forward or Reverse

1. Open free-wheeling valve V2.
 - Close Valve. Replace if defective.
2. Forward drive valve 4H-16 or reverse drive valve 4H-15 defective or is sticking.
 - Close Valve. Replace if defective.
3. Flow/Divider/Combiner valve FD1 defective or is plugged.
 - Close Valve. Replace if defective.
4. Counterbalance valve CB1 defective or is plugged.
 - Close Valve. Replace if defective.

4.2-8 Brake(s) will not Release

1. Brake valve 3H-17A defective or is sticking.
 - Clean valve. Replace if defective.
2. Brake orifice(s) 07 plugged.
 - Remove orifice(s). Clean and reinstall.
3. Brake cylinder(s) C4 defective.
 - Rebuild cylinder(s). Replace if damaged.

4.2-9 Brake(s) will not Release (Additional for machines with Integral Brakes)

1. Stuck or defective auto reset valve V3.
 - Check valve operation. Clean valve. Replace if defective.
2. Stuck or defective hand pump P2.
 - Check pump operation. Clean pump. Replace if defective.
3. Defective internal brake piston seals.
 - Check brake pack will maintain pressure. If pressure is not maintained replace seals.
4. Plugged or defective brake orifice 07.
 - Clear obstruction. Replace if defective.
5. Damaged integral brake in wheel motor.
 - Inspect wheel motor assembly. Repair and replace as necessary.

Hydraulic System (Continued)**4.2-10 Aerial Platform will not hold on a Grade (Machines with Integrals Brakes)**

1. Worn or damaged brake discs.
 - Inspect brake discs for wear. Replace if worn or damaged.
2. Broken or damaged brake compression springs.
 - Check springs. Replace if defective.

4.2-11 Platform does not Steer

1. Right steer valve 4H-23 or left steer valve 4H-24 defective or sticking.
 - Clean valve. Replace if defective.
2. Steer cylinder C3 seals leaking.
 - Rebuild cylinder(s). Replace if damaged.
3. Mechanical binding in king pins.
 - Check for binding. Repair as needed.
4. Orifices 03 plugged.
 - Clean orifices, and reinstall.

4.2-12 All System sluggish

1. System Relief Valve defective or not adjusted properly.
 - Adjust valve. Replace if defective.
2. Hydraulic pump P1 worn.
 - Check pump. Replace if defective.
3. Proportional valve 2H-59 contaminated or defective.
 - Clean. Replace if defective.

4.2-13 Power Extension Platform will not Extend or Retract

1. Platform extend valve 4H-26 or platform retract valve 4H-27 defective or is sticking.
 - Clean valve. Replace if defective.
2. Powered platform cylinder C5 seals defective.
 - Rebuild cylinder. Replace if damaged.
3. Mechanical binding in power extension platform mechanism.
 - Check for binding. Repair as needed.

4.2-14 High/Low Torque Inoperative

1. Stuck speed valve 3H-18A-1.
 - Clean valve. Replace if defective.
2. Stuck speed valve 3H-18A-2.
 - Clean valve. Replace if defective.

Section 5 - PROCEDURES

Service & Maintenance

General.....	111
Safety and Workmanship.....	111

Platform

5.1-1 OEM Controller Electronics Information	111
5.1-2 OEM Controller Troubleshooting	112
5.1-3 OEM Controller Switch Wiring	113
5.1-4 Gate Spring Hinge Adjustment	114
5.1-5 Railing Modification to Enhance Resistance to Damage.....	115

Base

5.2-1 System Relief Pressure Adjustment.....	117
5.2-2 Lift Pressure Adjustment	117
5.2-3 Electronic Tilt Switch Setup Procedure.....	118
5.2-4 Pothole Limit Switches (LS4 & LS5) Replacement and Adjustment	122
5.2-5 Wheel Replacement and Torquing Procedure.....	123
5.2-6 Tightening and Torque Recommendations for Hydraulic Couplings and Hoses	129
5.2-7 Battery Maintenance	131
5.2-8 Charger Maintenance - Delta-Q.....	131

Scissors

5.3-1 High Speed Cutout Limit Switches (LS1A & LS1B) & Drive Override Limit Switch (LS6) Replacement and Adjustment.....	139
--	-----



General

The following information is provided to assist you in the use and application of servicing and maintenance procedures contained in this chapter.

Safety and Workmanship

Your safety, and that of others, is the first consideration when engaging in the maintenance of equipment. Always be conscious of weight. Never attempt to move heavy parts without the aid of a mechanical device. Do not allow heavy objects to rest in an unstable position. When raising a portion of the equipment, ensure that adequate support is provided.

Unless specifically noted otherwise, before beginning any procedure:

1. Park the mobile elevating work platform (MEWP) on a firm, level surface.
2. Fully lower the machine.
3. Push in the “” emergency stop buttons on the platform control console and the base control console.
4. Turn the off/platform/base key switch to the “” off position. Remove the key.
5. Turn the main power disconnect switch to the “” off position.

After completing any procedure which involves modifying, adjusting, or replacing any hydraulic or electrical components, perform all of the function tests given in your unit's Operating Manual.

Platform

5.1-1 OEM Controller Electronics Information

Flow Control

Single coil or solenoid for single direction. The coil has two connections; one is wired to the P.C. Board (A) terminal and the other is wired to (-), or the negative side of the supply voltage. Switches to control directional valves may be provided on the controller.

Adjustment Procedures

Adjustments are made by turning a trimpot adjustment screw. The trimpots are multi-turn, end-to-end devices. It may be necessary to turn the adjustment screw several turns to observe a change in output.

Clockwise (CW) adjustment of the trimpot increases the output.

Counter-clockwise (CCW) adjustment of the trimpot decreases the output.

Adjustments affect output current, voltage or percentage of duty cycle to the coil. The minimum and maximum output is preset at the factory. However, for optimum performance, they must be adjusted while the equipment is operating.

Although the following adjustments affect the current/voltage or percentage of duty cycle, the best way to adjust the function is to observe the response or speed of the function. The following adjustments affect function response, or speed. There may be some interaction between adjustments, making it necessary to repeat the adjustment in order to achieve the desired response.

“Threshold” Adjustments

Adjusts the initial current flow or duty cycle, affecting the function response or speed when the handle is first moved from the off position. Deflect the handle slowly to the position where the controller first turns on. Adjust the threshold trimpot screw to the point where the controlled function just starts to move, then turn the trimpot screw one, full turn in the counterclockwise direction. This adjustment should be done first.

“Maxout” Adjustments

Adjusts the full stroke current or duty cycle affecting the maximum function response, or speed when the handle is deflected to its full travel. Fully deflect the handle, and adjust the maxout trimpot for maximum desired function response or speed. To obtain proportional resolution, it is important that the function starts to slow down as soon as the handle is moved back from the fully deflected position.

The ideal adjustment occurs when the function just begins to move when the handle is deflected, and the output increases until it reaches its maximum desired response or speed at the end of handle travel.

5.1-2 OEM Controller Troubleshooting

Problem

1. The function will not operate when the handle is moved. The LEDs do not light
 - A. Check that voltage is present at the positive (+)input terminal.
 - B. Check that ground is connected to the negative (-) terminal.
 - C. If there is an in-line fuse, check to see if it is good.
 - D. Check the controller on/off switch and the connectors. Voltage should be present at the (X) terminal when the controller is turned on.
 - E. Check that valve wiring is not shorted to ground. The LEDs will not light.
 - F. Check that valve wiring is not open. The LEDs will light, but the intensity will not vary.
 - G. Check trimpot settings. Fully "CCW" turns output off, "CW" turns output fully on.
2. The function jumps or lurches when turned on.
 - A. Perform "Threshold" adjustment procedures.
3. The function reaches maximum speed before the handle is fully deflected,
 - A. Perform "Maxout" adjustment procedures.
4. The function speed remains constant regardless of the degree of handle deflection.
 - A. Perform "Maxout" adjustment procedures.

IRS Option

1. Function speed reacts too slowly or too quickly in relation to handle deflection.
 - A. Check "IRS" (Ramp) trimpot adjustment. "CW" increases ramp time, "CCW" decreases ramp time.

Integrated Ramp System (IRS)

Provides smooth function response ,when reacting to an abrupt change in handle deflection. "CW" rotation of the trimpot increases ramp time and slows the response time. "CCW" decreases ramp time and increases the response time. To increase the ramp time, turn the adjusting screw "CW" a few turns, then move the controller handle abruptly. Continue to adjust until a smooth response is observed. Most controllers have on/off contacts which remove power from the P.C. Board when the handle is returned to the off position. When the handle is abruptly returned to neutral, the output will not ramp down, and the function will stop.

Ramp Thru Off

The P.C. Board should be adjusted as outlined in the IRS adjustment procedure. If the handle is abruptly returned to neutral (OFF) the output will ramp down to off. Ramp time is factory set to 2 seconds, unless otherwise specified.

NOTE

Trimpots should be sealed with nail polish or enamel based paint.



WARNING

Do not use RTV silicone.

5.1-3 OEM Controller Switch Wiring

WIRE CHART		
COLOR	FROM	TO
WHT/RED	STEER LEFT	PIN #1
WHT/GRN	STEER COMMON	PIN #2
WHT	STEER RIGHT	PIN #3
YEL	FORWARD/UP	PIN #4
WHT/BLK	+24V INPUT	PIN #5
GRY	REVERSE/DOWN	PIN #6
BLU	PWM OUT (A)	PIN #7
BLK	GROUND (-)	PIN #8
WHT/BLU	ENABLE OUT	PIN #9

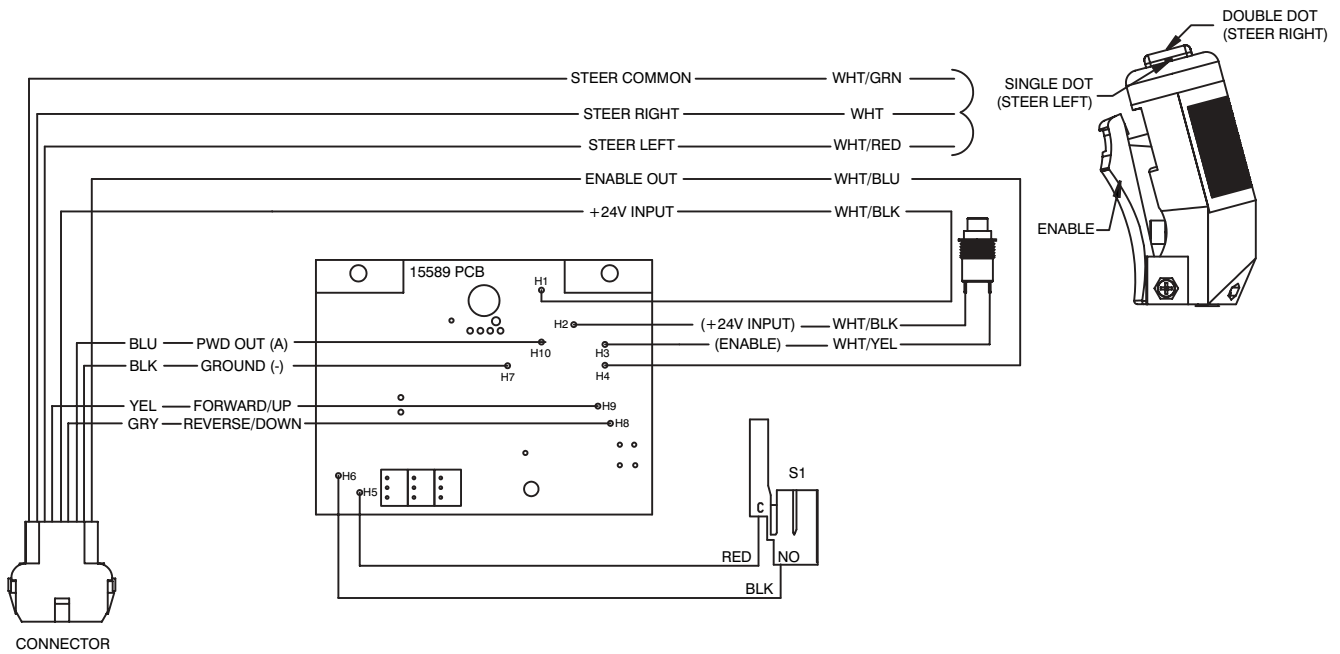

5.1-4 Gate Spring Hinge Adjustment

1. The tension of the spring hinges should be such that when the gate is opened halfway and released, it will close fully and latch.
2. To adjust the tension of the spring hinges, first remove the safety locking screw of each hinge. Retain the screws for reinstallation later.

If Locking Screw Located at the Top or Bottom of the Spring Hinge,

3. To increase the tension, insert a 5/32" hex wrench in the screw socket, and turn the wrench clockwise. To release the tension, depress the hex wrench in the socket, let it rotate counterclockwise, then release the hex wrench.

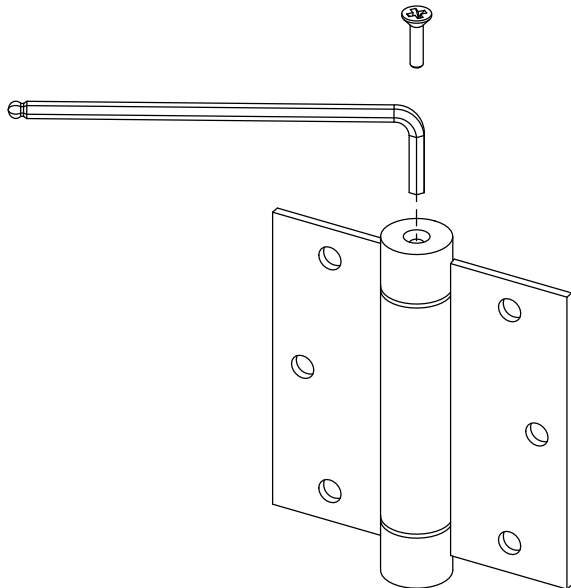

4. Adjust the tension on both hinges until the gate releases and latches from a half open position.
5. Reinstall the safety locking screws into the hinges when tension adjustment is complete.

If Locking Screw Located at the Side of the Spring Hinge,

NOTE

Adjusting the tension on the spring hinge is a two handed operation.

6. To increase the tension, insert a 5/32" hex wrench in the screw socket. Turn the wrench clockwise to desired tension as well as aligning the locking screw hole. Hold the wrench in place, maintaining the selected tension, while reinstalling the locking screw.

NOTE

Ensure the holes inside the hinges are aligned before inserting the locking screw.

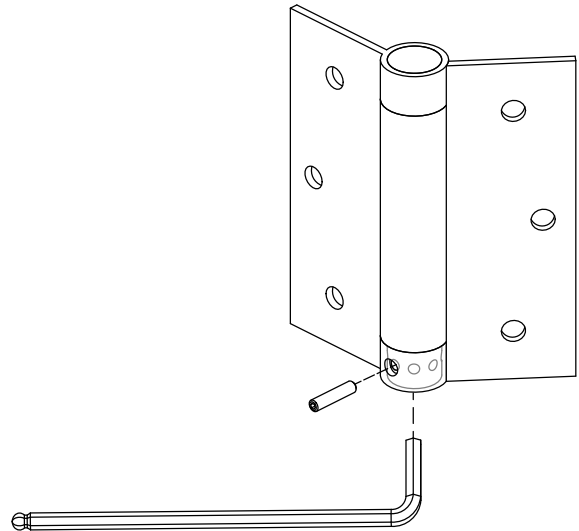

7. Adjust the tension on both hinges until the gate releases and latches from a half open position.

5.1-5 Railing Modification to Enhance Resistance to Damage

Applies to the following serial numbers:
SJIII 3220 - 60 003 548 & below
SJIII 3226 - 27 013 592 & below
SJIII 46XX - 70 013 810 & below

Machine Preparation

1. Ensure the mobile elevating work platform (MEWP) is on a firm, level surface.
2. Fully lower the machine.
3. Ensure there is enough room to extend the extension deck fully.
4. Push in the "⊙" emergency stop buttons on the platform control console and the base control console.
5. Turn the off/platform/base key switch to the "○" off position. Remove the key.
6. Turn the main power disconnect switch to the "○" off position.

Tools Needed

- Cut off disc or metal saw
- Grinding disc
- 1/2" (13 mm) wrenches x 2
- Touch up paint

Hardware Needed

- 103865 - BOLT, Hex Hd Zinc - 5/16"-18 x 2" Gr. 5 Qty. 2
- 103984 - NUT, Hex Lock - 5/16"-18 Gr. B Qty. 2

Guardrail Modification

WARNING

Ensure that you maintain three points of contact when using the ladder to mount/dismount the platform.

1. Enter the scissor lift and close the gate or entry chain.
2. Slide out the extension deck fully, exposing the vertical strut completely, and lock it in place with pins.
3. Use an appropriate metal cutting saw or grinder such as an angle grinder with a cut-off disc for the following step.

WARNING

Risk of severe injury. Ensure your angle grinder is in good working condition and wear appropriate personal protective equipment (PPE).

4. Cut through the top of the vertical strut, as shown below. Do not cut into the horizontal square tube.

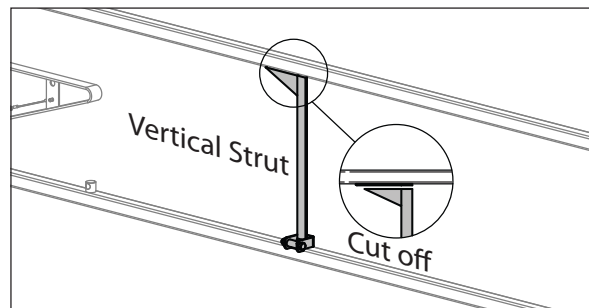

5. Remove and throw out the hardware from the vertical strut hinge. Remove and throw out the strut.
6. Use a grinding disc on the upper horizontal rail to remove as much of the remaining strut as possible, without grinding into the square tube. Remove all sharp edges.

7. Remove and discard the two hex head bolts and lock nuts from the rear of the extension handrail.

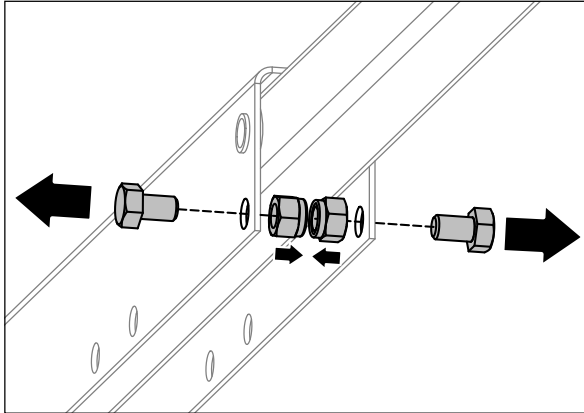

8. Install a single new hex head bolt (103865 - 5/16"-18 x 2" Gr. 5) and lock nut (103984 - 5/16"-18 Gr. B). Position the bolt with the hex head on the inside of the platform. Use two 1/2" (13 mm) wrenches to tighten the nut and bolt.

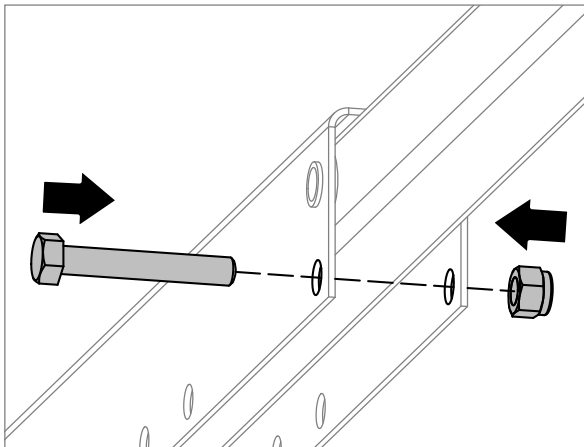

9. Repeat steps 3 to 8 on the other side of the platform.
10. To prevent rust, paint the exposed steel.
11. When the paint is completely dry, slide the extension deck in completely.

Base**5.2-1 System Relief Pressure Adjustment**

1. Locate the system pressure quick disconnect port on the main manifold.
2. Install a calibrated 5000 psi gauge to the system pressure quick disconnect port.
3. Remove the platform control console the guardrail and disconnect from the main control cable.
4. Locate the main control cable plug at the rear of the aerial platform.
5. Disconnect the main cable and connect the platform control console into the plug.
6. At the main manifold, loosen the locknut on the system relief valve R1.
7. Select drive with the lift/drive select switch on the platform control console.
8. Engaged steer right and hold.
9. Observe reading on gauge. Adjust the R1 system relief value listed on the serial number plate. Turning the stem on the relief valve clockwise will increase pressure. Turning the stem counterclockwise will decrease pressure.
10. Release steer switch and tighten the locknut.
11. Remove the gauge from system pressure test port.

5.2-2 Lift Pressure Adjustment**NOTE**

Adequate area to raise the platform to full height is required for the following steps.

1. Locate the lift pressure test port on the main manifold.
2. Install a calibrated 3000 psi gauge to the lift pressure quick disconnect port.
3. At the main manifold, loosen the locknut on the lift relief valve R2.
4. Close the manual lowering valve. Use the lift switch at the base control console to raise the platform to full height and hold the lift up switch on.
5. Observe the reading on the gauge. Adjust the R2 relief valve to the value listed on the serial number plate. Turning the stem of the relief valve clockwise will increase pressure. Turning the stem counterclockwise will decrease pressure.
6. Remove the gauge from lift pressure test port.

NOTE

Pressure setting may vary as aerial platform components wear. The lift pressure should be set for rated load only.

5.2-3 Electronic Tilt Switch Setup

Procedure

The following information is supplied for replacement or reprogramming of the electronic tilt switch. Also included are test and verification instructions. Follow the appropriate procedures below.

Tilt Switch Replacement

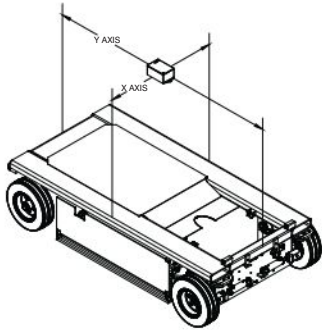

1. Ensure aerial platform is parked on a firm level surface.
2. Chock or block wheels to keep the aerial platform from rolling forward or backward.
3. Lower/Raise the platform and secure the scissors using the maintenance bars. (Refer to Operating manual for Maintenance Supports Procedure)
4. Push in "⊛" emergency stop buttons and turn main disconnect switch to "○" off position.
5. Remove any covers to locate and view the tilt switch.
6. Disconnect tilt switch from 4 pin connector.
7. Remove old tilt switch from mount.
8. Install new switch to mount (in the same orientation as the old switch) and connect switch plug to 4-pin connector.

NOTE

The tilt circuit is only powered when activating a function.

9. Disconnect all wires #02 from motor contactor.
10. Install jumper wire between #7 and #19 to terminal strip.
11. Pull out "⊛" emergency stop button and turn main disconnect switch to "I" ON position.
12. Verify switch is powered. (Red or green LED will be continually blinking)



13. Program the Tilt Switch

- a. Press and release the set up button 3 times.

- b. Observe program delay / stabilization time. (Only the red LED will blink for 4 seconds)

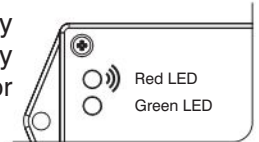

- c. Both LEDs will flash for 1 second. **Results:** The switch is learning the new zero position.

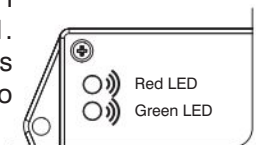

- d. Both LEDs will turn on solid for 1 second. **Results:** The new zero position has been learned.

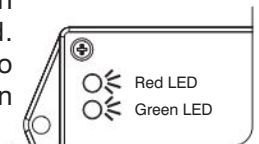

- e. The green LED will flash and then the red LED will turn on solid for 2 seconds.

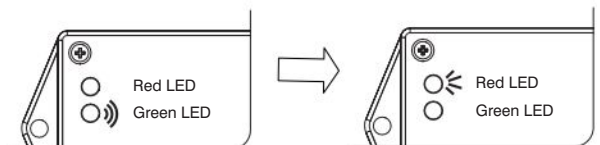

Results:

The switch is verifying the new zero position.

- f. The green LED will turn on solid. **Results:** The switch is ready for normal operation.

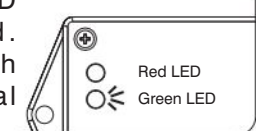

14. Turn main disconnect switch to "○" off position.

15. Remove jumper wire between #7 and #19 from terminal block.
16. Reattach all wires #02 to motor contactor.
17. Reinstall any covers that was removed.
18. Remove chock or wheel blocks.
19. Proceed to Test and Verify Tilt Circuit.

Reprogramming Existing Tilt Switch

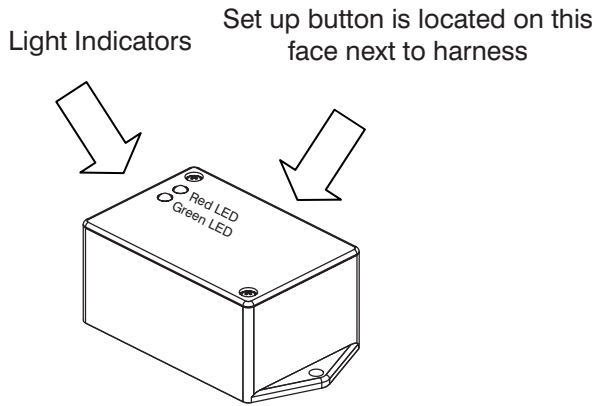

1. Ensure aerial platform is parked on a firm level surface.
2. Chock or block wheels to keep the aerial platform from rolling forward or backward.
3. Lower/Raise the platform and secure the scissors using the maintenance bars. (Refer to Operating manual for Maintenance Supports Procedure)

NOTE

The tilt circuit is only powered when activating a function.

4. Remove any covers to locate and view the tilt switch.
5. Disconnect all wires #02 from motor contactor.
6. Install jumper wire between #7 and #19 to terminal strip.
7. Turn main disconnect switch to "I" ON position.
8. Verify switch is powered. (Red or green LED will be continually blinking)

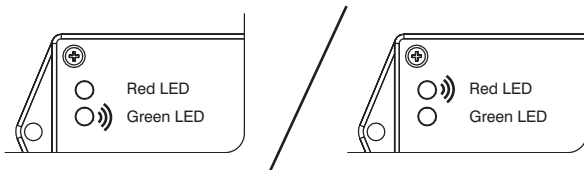

9. Reprogram the Tilt Switch

- a. Press and hold the setup button until both lights start to flash. (Approximately 5 sec.)

Results: Both LEDs will be OFF.

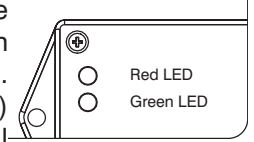

- b. Both LEDs will flash.

IMPORTANT

Step "c" must be completed within a 5 second period, or the switch will automatically exit program mode and return to normal operation using previously stored data.

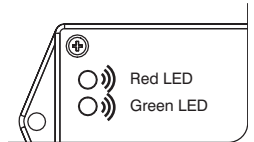

- c. Press and release set up button 3 times.
- d. If 5 second period has expired prior completion, repeat Step "a", "b" and "c".

- e. Observe program delay / stabilization time. (Only the red LED will blink for 4 seconds)

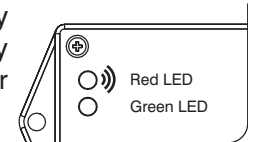

- f. Both LEDs will flash for 1 second. **Results:** The switch is learning the new zero position.

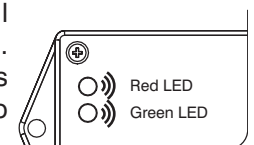

- g. Both LEDs will turn on solid for 1 second. **Results:** The new zero position has been learned.

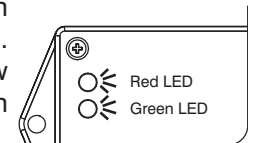

- h. The green LED will flash and then the red LED will turn on solid for 2 seconds.

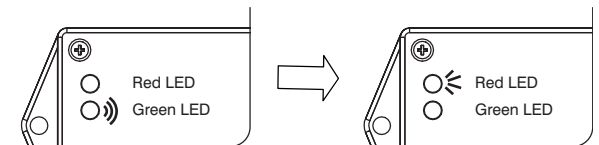

Results:

The switch is verifying the new zero position.

- i. The green LED will turn on solid.
Results: The switch is ready for normal operation.

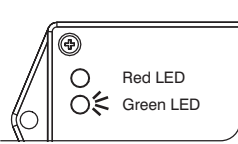

Test and Verify Tilt Circuit

Light Indicators Set up button is located on this face next to harness

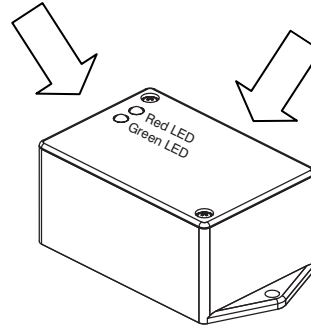

- 10. Turn main disconnect switch to “O” off position.
- 11. Remove jumper wire between #7 and #19 from terminal block.
- 12. Reattach all wires #02 to motor contactor.
- 13. Reinstall any covers that was removed.
- 14. Remove chock or wheel blocks.
- 15. Proceed to Test and Verify Tilt Circuit.

Operations of Tilt Switch

The following describes the LED’s and what they indicate.

Green LED	<p>Illuminated whenever both tilt axes are within the specified degrees of the zero/ home learned position.</p> <p>Flashes when transitioning in or out of tilt angle limits, but built in time delay has not fully occurred.</p>
Red LED	<p>Illuminated whenever tilt on one or more axes is more than the specified degrees out from the zero/ home position.</p>
Green & Red LED	<p>On together, no blinking when fault detected.</p>

Tilt Circuit Test

- 1. Refer to section 2 for test tilt sensor procedure.

5.2-4 Pothole Limit Switches (LS4 & LS5) Replacement and Adjustment

Machine Preparation

1. Ensure the aerial platform is parked on a firm level surface.
2. Chock or block the wheels to keep the aerial platform from rolling forward or backward.

Limit Switch Removal

1. Raise the platform until the pothole bars are deployed.
2. Swing out the hydraulic tray and the battery tray to gain access to the pothole limit switches underneath the base.
3. Remove the bolts and nuts (x2) securing each limit switch to the pothole lock plate. Set the hardware aside for later reinstallation.

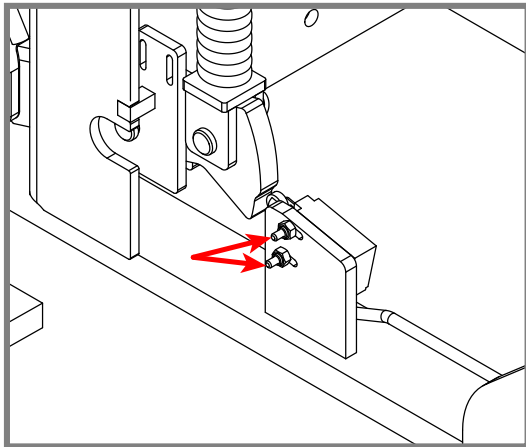

4. Remove the limit switch and free the limit switch cable by cutting the tie wraps.
5. Follow the cable into the electrical panel, and disconnect the limit switch wires from the electrical panel. Discard the limit switches.

Limit Switch Replacement

1. Mount loosely the new limit switch assemblies: 166003 (Battery Tray) & 125885 (Hydraulic Tray), using the hardware removed previously.

Limit Switch Electrical Connections

1. Route the new limit switch cable(s) along the same path as the old one(s) into the electrical panel cabinet. Use tie wraps as needed to secure them at regular intervals.
2. Strip the cable jacket back to separate the wires. Cut the wires to length if needed.
3. Strip the ends of wires 72-Black/White and 71-Black from the Battery Tray Limit Switch as well as wires 72-Black/White and 19-Black from the Hydraulic Tray Limit Switch and connect them to the electrical panel (refer to 3.19 Electrical Panel Wiring Diagram).

Limit Switch Setup

1. Loosen the hardware securing the limit switch to the pothole lock plate. Adjust and move the limit switch towards the lever bar until it makes contact inside the notch with the lever bar without depressing the plunger roller.

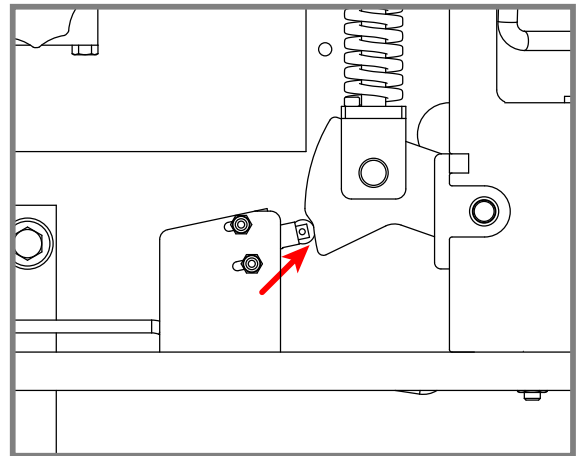

2. Fully tighten the bolts securing the limit switch. Ensure the limit switch does not move while tightening the bolts and the plunger roller retaining pin is fully visible.

Limit Switch Testing

1. Place a block, approximately 1.5" (3.75 cm), under the hydraulic/electric tray and then raise the platform to an approximate height of 7 feet (2 meters) or until the pothole protection is activated. Attempt to drive forward or reverse. Aerial platform should not move forward or backward.

5.2-5 Wheel Replacement and Torquing Procedure

Tools Needed

- Adjustable Torque Wrench
Capacity 380 Nm (280 ft-lb)
- Hub Puller

Grease Application - New Front Wheels Only (if required)

Model	Recommended Grease Type
SJIII 3220, SJIII 3226, SJIII 4626, SJIII 4632	STARPLEX EP2
	UNIREX EP2
	SHELL GADUS S2

1. If the bearings are provided separately, they will need to be coated in grease before installing on the front wheels.

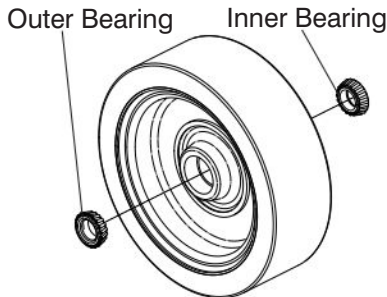

Front side shown

2. Thoroughly clean the bearings using solvent and allow them to dry.
3. Coat the inner and outer bearings with grease completely. Be careful not to contaminate the grease. This could cause internal damage and shorten the life span of the bearings. Contaminants include dust, dirt, sand, water or other foreign particles.
4. Install the inner and outer bearings. The grease should allow the bearings to stick to the bearing cups inside the wheel assembly.



NOTE

The inner bearing has a larger diameter than the outer bearing. When installing, ensure the bearings are inserted tapered-end first.

5. From the back side of the wheel, place the grease seal on the hub with the tapered end facing inwards.

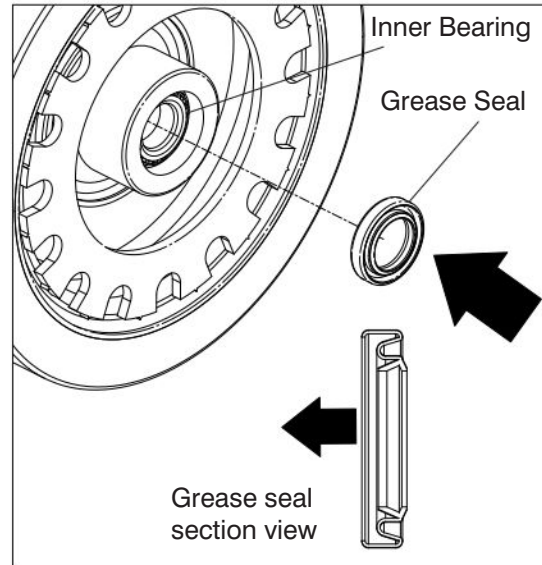

Back side shown

6. Lightly tap the grease seal into place using a hammer, protecting the grease seal with a flat piece of wood.

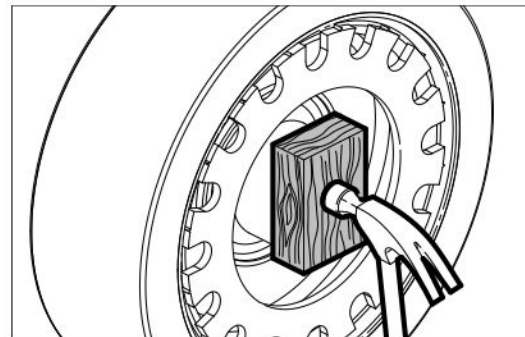

Hub/Integrated Hub Wheel Removal

1. Use an appropriately rated lifting device to raise up the MEWP until all the wheels are off the ground. Set the MEWP on stands adequately rated to support the weight of the machine.
2. Remove and set aside the wheel motor nut or castle nut.
3. Remove and discard the locktooth washer or cotter pin. A new one will be required for re-installing the hub/integrated hub wheel.
4. Use a hub puller to remove and discard the hub/integrated hub wheel from the wheel motor or brake.
5. For integrated hub wheels, use two 3/8"-24 bolts with a hub puller to remove the wheel.

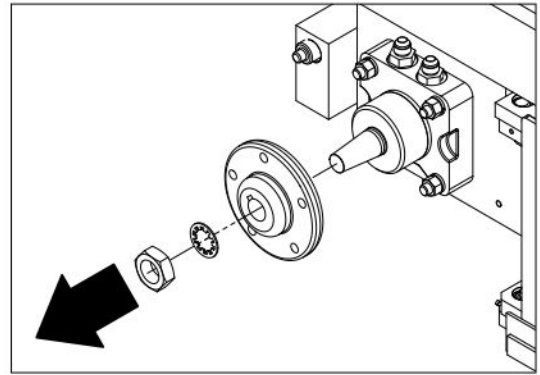
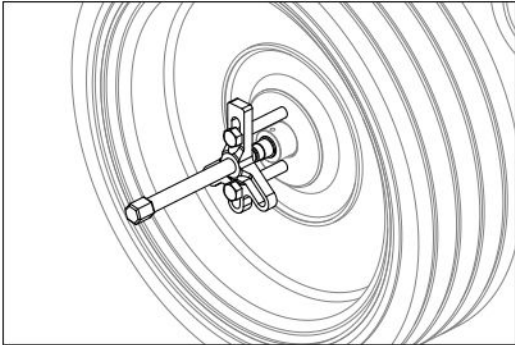
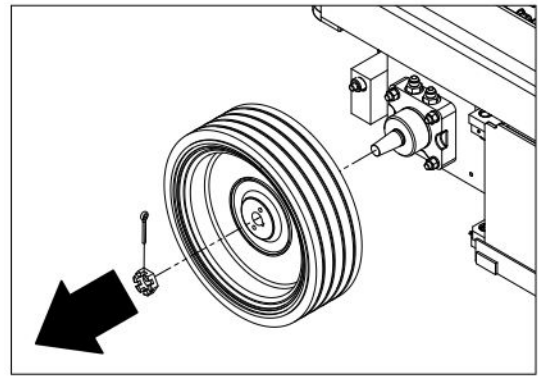
**Remove Hub****Remove Integrated Hub Wheel**

Front Hub/Integrated Hub Wheel Installation

1. Install the hub/integrated hub wheel onto the spindle.
2. Install the castle nut and the flat washer. Finger tighten the nut.
3. For integrated hub wheels, use a wrench to manually disengage the pin brakes on both sides. This will allow you to rotate the wheel.
4. Rotate the hub/wheel slowly while tightening the castle nut to approximately 68 Nm (50 ft-lb). This is to seat all the bearings in the wheel assembly.



NOTE

Do not over-torque the castle nut as the bearing life would be reduced.

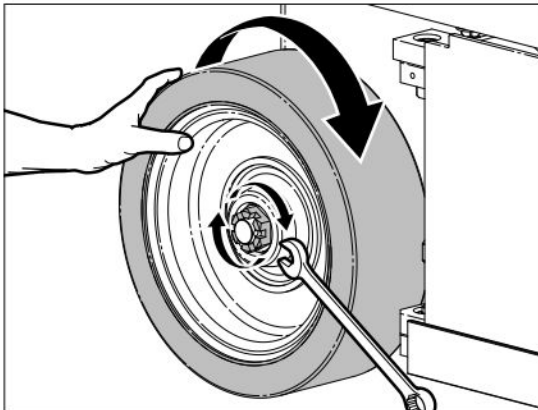

5. Loosen the castle nut to remove the torque. Do not rotate the wheel.
6. Finger tighten the castle nut until it is snug.



NOTE

The castle nut should be free to rotate, with the only restraint being the cotter pin.

7. Use a wrench to re-engage the pin brakes on both sides. Do not lower the machine while the pin brakes are disengaged.
8. Turn the castle nut back slightly until the next cotter pin hole is visible on the spindle.
9. Install a 3/16" x 1-1/2" cotter pin.

10. Ensure the cotter pin is pushed in completely.
11. Bend the ends of the cotter pin to secure the castle nut.
12. Install the dust cap over the castle nut. Be sure not to damage the castle nut while installing the dust cap.

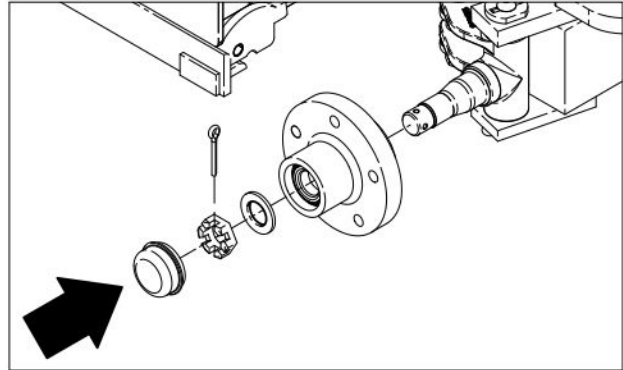

Hub Install

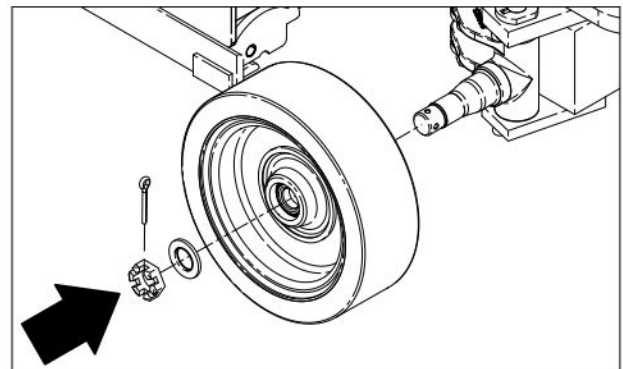

Integrated Hub Wheel Install

Rear Hub/Integrated Hub Wheel Installation - Pin Brakes

1. Install the hub/integrated hub wheel onto the spindle.
2. Install a 1" castle nut onto the brake.
3. Tighten the castle nut to 95 Nm (70 ft-lb) and insert the 1/8" x 1-1/2" cotter pin.
4. If the holes do not align to install the cotter pin, continue to torque the castle nut clockwise until the next hole is visible.
5. Ensure the cotter pin is pushed in completely.
6. Bend the ends of the cotter pin to secure the castle nut.

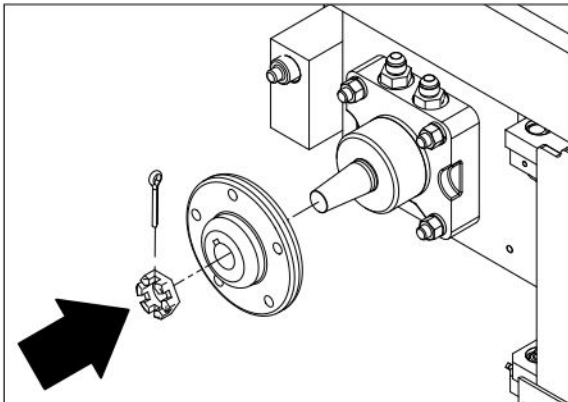
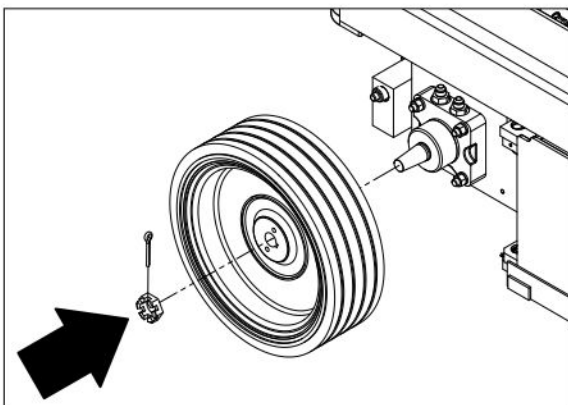
**Hub Install****Integrated Hub Install****If using a wheel motor nut**

7. Install a wheel motor nut and the new locktooth washer onto the hub/wheel.
8. Torque the wheel motor nut to 380 Nm (280 ft-lb).
9. Apply torque seal to the wheel motor nut.

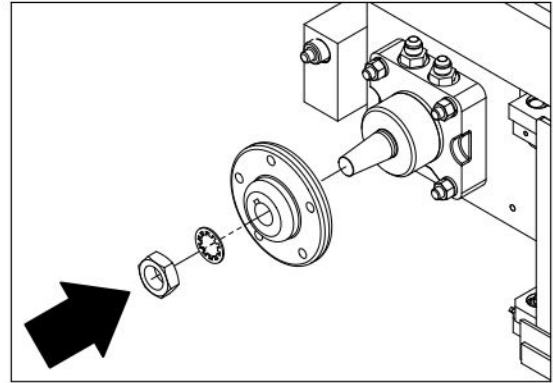
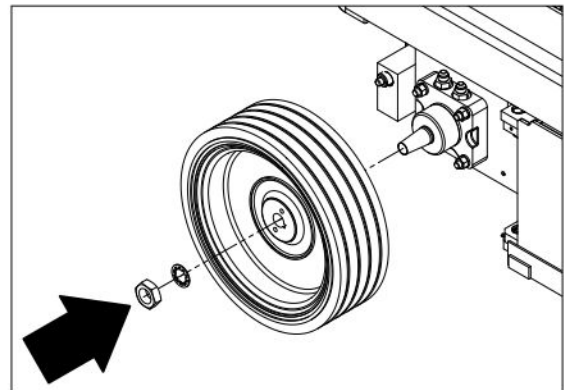
**Hub Install****Integrated Hub Wheel Install**

Rear Hub/Integrated Hub Wheel Installation - Wet Brakes

1. Install the hub/integrated hub wheel onto the spindle.
2. Install a 1" castle nut onto the the brake.
3. Tighten the castle nut to 95 Nm (70 ft-lb) and insert the 1/8" x 1-1/2" cotter pin.
4. If the holes do not align to install the cotter pin, continue to torque the castle nut clockwise until the next hole is visible.
5. Ensure the cotter pin is pushed in completely.
6. Bend the ends of the cotter pin to secure the castle nut.

If using a wheel motor nut

7. A new 1" locktooth washer will be required for hub installation using a wheel motor nut.
8. Torque the wheel motor nut to 380 Nm (280 ft-lb).
9. Apply torque seal to the wheel motor nut.

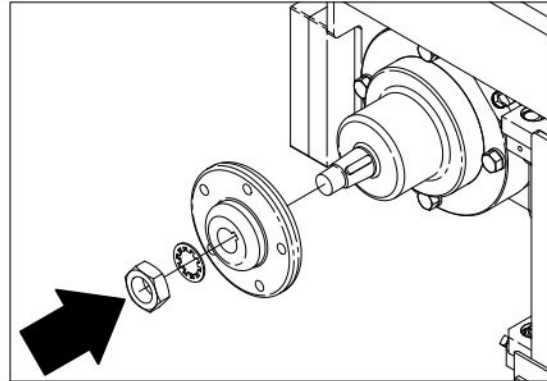

Hub Install

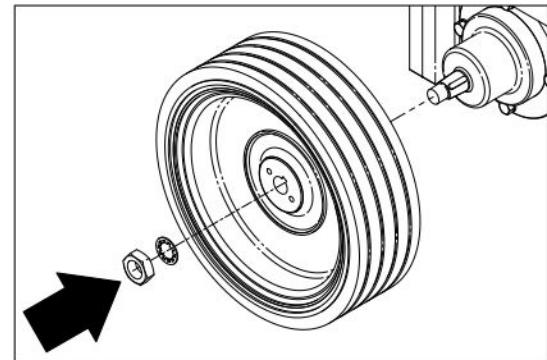

Integrated Hub Wheel Install

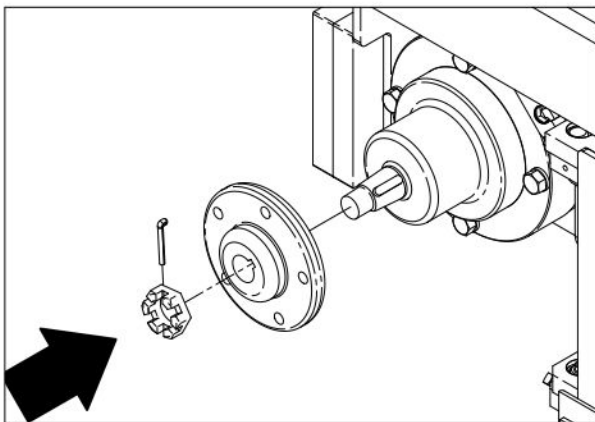

Hub Install

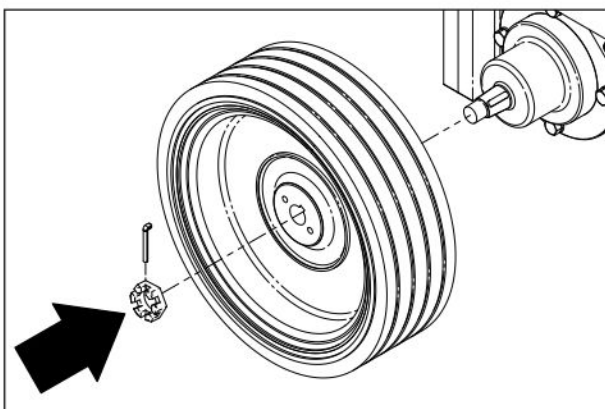

Integrated Hub Wheel Install

Wheel Installation (If applicable)

1. Install the wheel onto the hub.
2. Center the wheel mounting holes with the bolt holes from the hub.
3. Secure the wheel using wheel bolts and hand tighten to center the rim.

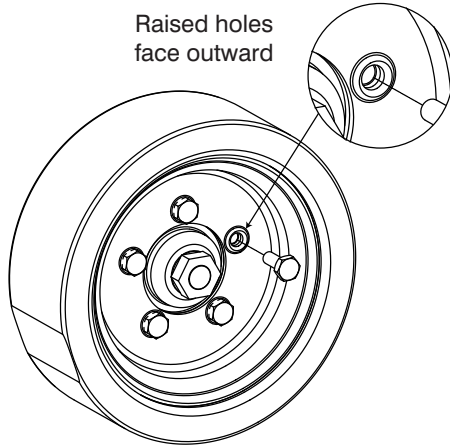

4. Torque the bolts to 68 Nm (50 ft-lb) in a criss-cross sequence.

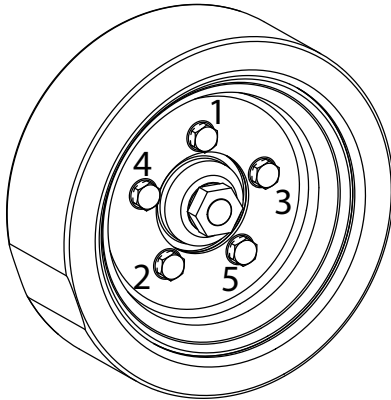

5. Tighten the bolts to 122 Nm (90 ft-lb) in a criss-cross sequence.
6. Repeat the tightening sequence to confirm that none have changed from 122 Nm (90 ft-lb). If any are found below 122 Nm (90 ft-lb), repeat complete sequence until there is no change in torque values. If possible, drive the machine prior to checking torques.
7. Apply dots of torque seal at the base of the wheel bolts.
8. Check torque values after 8 hours of operation.

5.2-6 Tightening and Torque Recommendations for Hydraulic Couplings and Hoses

General Work Practices

1. All components must be free of damage or contamination. O-rings cannot be reused anytime the component has been installed beyond finger tight. Clean or replace components, as required.
2. Over-tightening a coupling may result in overstressing and/or cracking, and may lead to leaking or failure.
3. When tightening hose couplings, ensure the hose does not twist on the adapter. Twisting will shorten hose life and scar the sealing surfaces of swivel type couplings (JIC, 45°, etc.), which can create leaks.
4. When tightening hose couplings, use a torque wrench (with crow's foot) on the hose end hex swivel nut, and a standard box wrench on the hose end stem hex to hold the hose from twisting.

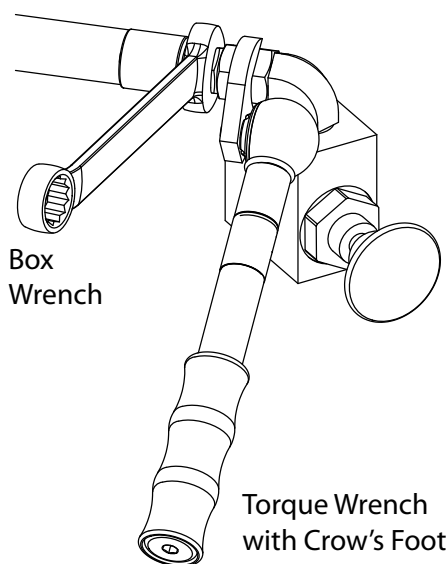

5. Lubricate all o-ring surfaces with suitable hydraulic oil prior to installation in the flange head and o-ring seal grooves. This will minimize the possibility of damage to the O-ring when installed.
6. Install any 45° and 90° hydraulic hose ends first, then align direction and tighten. Adjust the swivel nut on the straight hose end before tightening to create the desired flow.

Torquing Using a Torque Wrench

1. This method is applicable for JIC (37°) and FFOR (Flat Face O-Ring) hose ends and fittings, wherever the components are accessible with torque wrench / crow's foot tools.
2. Align the hose end or fitting to the mating component.
3. Install the nut two or three turns by hand to assure proper alignment. Jiggle the hose while tightening to ensure the faces contact fully.
4. Using a properly calibrated torque wrench, tighten the coupling using a smooth, even motion until an indication (audible click) is heard and felt. Do NOT over tighten. For recommended torque values, refer to [Table 2.8 Torque Specifications for Hydraulic Couplings & Hoses](#).
5. Apply a drop of torque seal to the connection.

Torquing Using the Flats From Wrench Resistance Method

1. This method is applicable for JIC (37°) and FFOR (Flat Face O-Ring) hose ends only, wherever the components are inaccessible with torque wrench / crow's foot tools, or when a properly calibrated torque wrench is not available.
2. Align the hose end or fitting to the mating component.
3. Install the swivel hose end nut hand tight to the fitting to assure proper alignment. Jiggle the hose while tightening to ensure the faces contact fully.
4. Tighten the nut using a box wrench until minor resistance is felt.

Section 5 - Procedures

Service and Maintenance

- Note the position of the nut relative to the fitting with a marking device (i.e., paint marker).

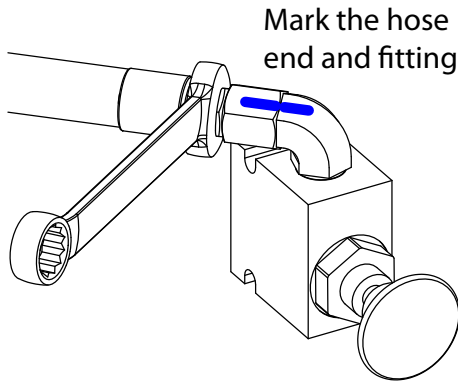

- Referencing the chart below, use a second box wrench to tighten the nut the appropriate number of flats past the mark. Do NOT over tighten.

FLATS FROM WRENCH RESISTANCE CHART for JIC Hose Ends			
Size		FFWR	
Dash	Frac. (in.)	37° Tube Nut	Swivel Nut
-4	1/4"	2	1.5
-5	5/16"	2	2
-6	3/8"	1.5	1.5
-8	1/2"	1.5	1.25
-10	5/8"	1.5	-
-12	3/4"	1.25	-
-16	1"	1	-
-20	1 1/4"	1	-
-24	1 1/2"	1	-
-32	2"	1	-

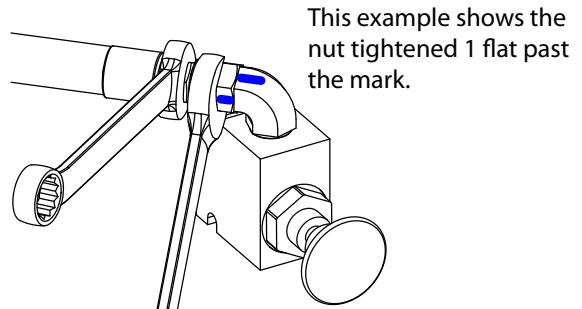

Using two Box Wrenches, tighten the nut the appropriate number of flats past the mark (refer to the FFWR chart above).

- Apply a drop of torque seal to the connection.

5.2-7 Battery Maintenance

This section provides the operator with procedures on how to service and charge the battery. This also provides the charger operation instructions.

Servicing the battery

⚠ WARNING



Explosion hazard. Keep flames and sparks away. Do not smoke near batteries. Battery acid releases explosive gas while charging. Charge batteries in a well-ventilated area.

⚠ WARNING

Battery acid is extremely corrosive – wear proper eye and facial protection as well as appropriate protective clothing. If contact occurs, immediately flush with cold water and seek medical attention.

1. Turn the main power disconnect switch to the off position.
2. Check the battery case for damage.
3. Check the battery fluid level in each battery. If the plates are not covered by at least 13 mm (1/2 in) of solution, add distilled or demineralized water.
4. Make sure all the battery connections are tight.

NOTE

Do not use any batteries other than the flooded lead-acid batteries of the proper Ah rating.

⚠ WARNING

Use the original or equivalent to the original parts and components for the MEWP.

5.2-8 Charger Maintenance - Delta-Q

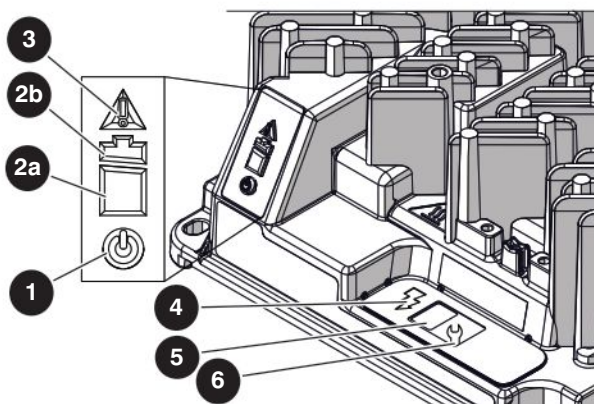

No.	Indicator type	State	Description/action required
1	AC power	Blue	Battery charger is connected to the AC power.
2a	Battery charging <80%	Flashing green	Low charge— continue charging.
		Solid green	High charge— continue charging.
2b	Battery charging >80%	Flashing green	High charge— can discontinue charging.
		Solid green	Charge complete— discontinue charging.
3	Fault/error	Solid red	Charger fault—refer to the service manual.
		Flashing amber	Error encountered— refer to the service manual.
4	Charging output	Solid yellow	Charger output is active.
5	Charge profile/error display	Current algorithm or fault/error code	N/A.
6	Select charge profile	Current charging algorithm	N/A.

Charger Profiles

IMPORTANT

Charge profiles differ depending on the battery type and manufacturer. Only use charge profiles with the batteries they were designed for. Using other incompatible batteries may cause poor charging performance and a decreased battery health.

- Place the charger near a power outlet, but leave it unplugged.
- Find your battery type in the following chart, and make a note of the profile number (starting with P).
- Press and hold the Select Charger Profile button (wrench icon) on the Delta-Q charger. You will hear a small click when you press the button.
- Continue to hold the Select Charger Profile button, and connect the charger to a power outlet.
- Continue to hold the button for approximately 10 seconds or until the Error Indicator turns orange and the Battery Charging Indicator starts flashing green.
- The current charger profile displays up to three times.



NOTE

The process times out and the profile remains unchanged if there are 15 seconds of inactivity, or if the charging profile is allowed to display three times.

- Press and release the button to scroll through the charging profiles.
- Select a profile, and press and hold the button for 10 seconds or until the Error Indicator and Battery Charging Indicator lights turn off.
- Press the button again to confirm the selected profile.
- Disconnect the charger from the power outlet.

Battery Brand	Compatible with	Profiles
U.S. Battery - US 2200 XC/XC2 Flooded, 6V, 232 Ah	200 - 255 Ah flooded	#11 (P-0-1-1)
East Penn - 8GGC2 Gel, 6V, 180 Ah	150 - 230 Ah gel	#26 (P-0-2-6)
Discover Energy - EVGC6A-A AGM, 6V, 220 Ah	220 - 400 Ah AGM	#43 (P-0-4-3)
Discover Energy - EV12A-A AGM, 12V, 140 Ah*		
U.S. Battery - US 12V XC2 Flooded, 12V, 155 Ah*	330 - 425 Ah flooded	#73 (P-0-7-3)
U.S. Battery - US 250 XC/XC2 Flooded-lead, 6V, 255 Ah		
Trojan - T105 ELPT Flooded, 6V, 225 Ah	150 - 250 Ah 6V, 8V, 12V flooded	#3 (P-0-0-3)

*The batteries used for these charger profiles are connected in a series-parallel circuit.

Figure 01 Delta-Q IC-650 Charger Profiles

Charger Troubleshooting

The IC Series charger is continuously monitoring itself and its environment for unusual conditions. There are a few indications that may require the user's attention.

Symptom	Recommended Action
No Indicator Lights	Check AC voltage and connection to wall power.
Only Blue AC Light On	Charger is connected to AC and is waiting for a battery to be connected, or for CAN remote control commands. Battery voltage must rise over 0.1V/cell before charging will begin. Some charging algorithms require a higher battery voltage to begin.
Solid Red Fault/Error Indicator	Read fault code (e.g., F-0-0-1) number on the Charge Algorithm/Error Display and refer to the fault code table.
Flashing Amber Fault/Error Indicator	Read error code (e.g., E-0-0-1) number on the Charge Algorithm/Error Display and refer to the error code table.

Charger Fault Codes

Fault Code	Description	Troubleshooting/Customer Actions
F-0-0-1	DC-DC Failure: LLC excessive leakage fault.	Internal charger fault. Disconnect AC and battery from charger for a minimum of 30 seconds. If it fails again, contact Skyjack service.
F-0-0-2	Power Factor Correction (PFC) Failure: PFC excessive leakage fault.	
F-0-0-3	PFC has taken too long to boost.	
F-0-0-4	The charger has been unable to calibrate the current offset.	
F-0-0-5	The voltage drop across the DC relay is too high while the relay is closed.	
F-0-0-6	Large difference between internal DC-DC and battery sense currents.	

Charger Error Codes

Fault Code	Description	Troubleshooting/Customer Actions
E-0-0-1	Battery voltage over limit in software. Typically 2.5V/cell. At the start of a charger cycle only and only for lead acid batteries. It is acceptable for the voltage to go above this during charging and when charging Lithium batteries.	<ul style="list-style-type: none"> ▪ Check the battery voltage and cable connections. ▪ Check charger voltage model is appropriate for batteries. ▪ This error automatically clears once the condition has been corrected.
E-0-0-2	Battery voltage too low to start a charge cycle. Algorithm dependent. Typically 0.1V/cell.	<ul style="list-style-type: none"> ▪ Check the battery voltage and cable connections. ▪ Check the charger is the correct voltage for the batteries it is connected to. ▪ Check battery size and condition. Batteries may be overdischarged. Use another charger to bring the batteries above the minimum voltage. ▪ This error automatically clears once the condition has been corrected.
E-0-0-3	Charge time limit reached. Algorithm dependent.	<ul style="list-style-type: none"> ▪ Charger output reduced due to high temperatures. Operate at lower ambient temperature. ▪ Charger output reduced due to low AC voltages. Check AC voltages. ▪ Check for shorted or damaged cells. ▪ Poor battery health. Replace the battery. ▪ Batteries too large for the charger. Replace batteries. ▪ Very deeply discharged battery. Retry charge. ▪ Battery connections are loose or corroded. Check connections. ▪ Extra loads. Turn off other devices running on the battery ▪ This error automatically clears once the charger is reset by cycling DC or by loss of AC for over 10 minutes.
E-0-0-4	Battery could not be trickle charged up to the minimum voltage. May also be used for other battery-related errors depending on the algorithm.	<ul style="list-style-type: none"> ▪ Check for shorted or damaged cells. ▪ Poor battery health. Replace the battery. ▪ Check DC connections. ▪ May be caused because of output reduced due to high temperature. ▪ Some new batteries may trigger these alarms as there voltage dips ▪ when charging starts before it goes onto rise.
E-0-0-7	Charge amp-hour Limit reached. Algorithm dependent.	<ul style="list-style-type: none"> ▪ Charger output reduced due to high temperatures. Operate at lower ambient temperature ▪ Charger output reduced due to low AC voltages. Check AC voltage. ▪ Check for shorted or damaged cells. ▪ Poor battery health. Replace the battery. ▪ Very deeply discharged battery. Retry charge. ▪ Battery connections are loose or corroded. Check connections. ▪ Extra loads. Turn off other devices running on the battery ▪ This error automatically clears once the charger is reset by cycling ▪ DC or by loss of AC for over 10 minutes.

E-0-0-8	Battery temperature out of range. Algorithm dependent.	<ul style="list-style-type: none"> ▪ Cool or warm batteries as needed. ▪ Check temperature sensor and connections. ▪ This error automatically clears once the condition has been corrected.
E-0-1-1	Charge disabled by external command	<ul style="list-style-type: none"> ▪ Charger has been disabled by an external controller over the CANbus network. ▪ This error automatically clears once the command has been removed.
E-0-1-2	Reverse polarity	<ul style="list-style-type: none"> ▪ Battery is connected the wrong way around. Check the battery connections. ▪ This error automatically clears once the condition has been corrected.
E-0-1-3	Battery does not take current	<ul style="list-style-type: none"> ▪ Check for an electrical component or loose connection between the charger and the battery. ▪ When charging lithium batteries, make sure the charger is properly connected to the battery and battery management system. ▪ This error automatically clears once the charger is disconnecting DC or AC.
E-0-1-9	Hardware build does not support software version	<ul style="list-style-type: none"> ▪ The charger hardware does not support the new software version. ▪ Existing SW is left running. Contact Delta-Q Technologies.
E-0-2-0	No active algorithm selected	<ul style="list-style-type: none"> ▪ Reprogram the charger with its original software, algorithms, and settings. ▪ Use the wrench button to select the correct algorithm if still available on the charger. ▪ The problem clears automatically when an available algorithm is set on the charger, as default.
E-0-2-1	High battery voltage while charging. Algorithm dependent. Typically 2.8V/cell.	<ul style="list-style-type: none"> ▪ When already charged, some new batteries may exhibit this error. ▪ Disconnect the battery connection and wait for the battery voltage to fall. Reconnect the batteries to see if the condition reoccurs. ▪ Check battery size and condition. Batteries in poor condition, with a high internal resistance, may cause this error. New batteries, if charged when already full, may also cause this error. Disconnect and reconnect the batteries a few times. ▪ Check the battery voltage and cable connections. ▪ This error automatically clears once the condition has been corrected.

E-0-2-2	Low battery voltage while charging. Algorithm dependent. Typically 0.1V/cell.	<ul style="list-style-type: none"> ▪ Another device may be drawing current from the battery. ▪ Check the battery voltage and cable connections. ▪ Check battery size and condition. Batteries may be overdischarged. ▪ Use another charger to bring the batteries above the minimum voltage. ▪ This error automatically clears once the condition has been corrected.
E-0-2-3	High AC voltage error (>270 VAC)	<ul style="list-style-type: none"> ▪ AC voltage is too high. Connect charger to an AC source that has a stable AC voltage between 85 and 270 VAC/45-65 Hz. ▪ In newer software versions this does not prevent charging. ▪ This error will automatically clear once the condition has been corrected.
E-0-2-4	Charger failed to turn on properly	<ul style="list-style-type: none"> ▪ Disconnect AC input and battery for 30 seconds. If the error persists, contact Delta-Q Technologies.
E-0-2-5	AC voltage has dipped below 80 VAC 3 times in 30 seconds	<ul style="list-style-type: none"> ▪ AC source is unstable. This could be caused by an undersized generator and/or input cables that are too long or too small. ▪ Connect the charger to an AC source with a stable AC voltage between 85 and 270 VAC/45-65 Hz. ▪ This error will automatically clear once the condition has been corrected.
E-0-2-8	Attempt to select algorithm incompatible with this software	<ul style="list-style-type: none"> ▪ Update charger software, continue to use existing algorithm* or select a different charging algorithm that is compatible. <p>* Notes</p> <ul style="list-style-type: none"> ▪ If selecting a different algorithm, the existing algorithm will remain in the charger. ▪ If upgrading an existing algorithm, the existing algorithm will be deleted. Contact Delta-Q Technologies for a software upgrade to run the new algorithm.
E-0-2-9	Cannot transmit on CAN bus	<ul style="list-style-type: none"> ▪ Check the physical CAN connector, electrical bus conditions, and other CAN modules for correct functioning. For example, check that termination resistance is approximately 60 ohms.
E-0-3-0	CAN heartbeat timeout on Battery module	<ul style="list-style-type: none"> ▪ May be caused by a missing heartbeat message. Check the CAN bus battery module for correct function. ▪ This error automatically clears once the condition has been corrected.
E-0-3-1	The Vref for the ADC measurements has triggered an alarm	<ul style="list-style-type: none"> ▪ Internal charger error. Disconnect AC and the battery for a minimum of 30 seconds and retry. ▪ If the problem persists, contact Delta-Q Technologies. ▪ This error automatically clears once the condition has been corrected.

E-0-3-2	CAN Heartbeat Lost	<ul style="list-style-type: none"> ▪ An error was detected with the CAN heartbeat communications with a registered node being guarded. ▪ Check the networked CANbus device(s) for correct functioning. ▪ This alarm does not display or get logged on the charger but does appear on the CAN bus via an emergency message.
E-0-3-6	Battery temperature sensor is missing or shorted	<ul style="list-style-type: none"> ▪ Check sensor connections. ▪ The charger behavior when this fault occurs can be configured. OEMs may contact Delta-Q Technologies for more information. ▪ This error automatically clears once the condition has been corrected.
E-0-3-8	Fan will not turn	<p>(Fan-equipped models only)</p> <ul style="list-style-type: none"> ▪ Check fan connections. ▪ Check to make sure the fan turns freely and is not obstructed. ▪ This error automatically clears once the condition has been corrected.
E-0-4-0	Fan voltage pulled low	<p>(Fan-equipped models only)</p> <ul style="list-style-type: none"> ▪ Check to make sure the fan turns freely.
E-0-4-5	Battery disconnected	<ul style="list-style-type: none"> ▪ Battery disconnected ▪ Reconnect the battery or check the wiring
E-0-4-6	Invalid PDO Length	<ul style="list-style-type: none"> ▪ Check to make sure all PDOs are valid length. ▪ This error automatically clears once the condition has been corrected
E-0-4-7	Platform overvoltage alarm	<ul style="list-style-type: none"> ▪ A battery or some other source has been connected to the charger that exceeds the hardware's design limits.

Scissors

5.3-1 High Speed Cutout Limit Switches (LS1A & LS1B) & Drive Override Limit Switch (LS6) Replacement and Adjustment

Machine Preparation

1. Ensure the aerial platform is parked on a firm level surface.
2. Chock or block the wheels to keep the aerial platform from rolling forward or backward.

Limit Switch Removal

1. Raise the platform to give access to the limit switch cable, and deploy the maintenance stand.
2. Turn the emergency main power disconnect switch to the OFF position.
3. Remove the gear clamp securing the limit switch cover, and slide the limit switch cover off of the pin. Set aside the clamp for reinstallation later.
4. Remove the bolts, washers, and nuts securing the limit switches to the cover. Set the cover and hardware aside for reinstallation later.

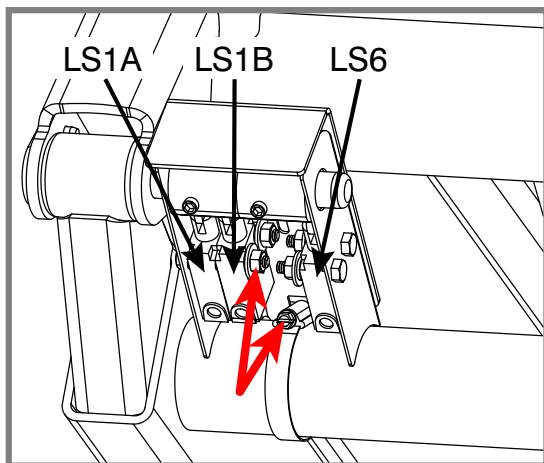

5. Remove the limit switches and free the limit switch cable(s) by cutting the tie wraps.
6. Follow the cable into the plug and disconnect it from the rear harness. Discard the limit switches.

Limit Switch Replacement

1. Mount the new limit switch assembly, 130559, using the hardware removed previously.

NOTE: High Speed Cutout Limit Switch (LS1A) is the one closest to the scissor arm, then LS1B adjacent to it, and Drive Override Limit Switch (LS6) on the opposite side.

2. Slide the limit switch cover back onto the pin. Secure it with the gear clamp removed previously.

Limit Switch Electrical Connections

1. Route the limit switch cable(s) along the same path as the old one(s) into the 4-pin connector in the rear harness. Use tie wraps as needed to secure them at regular intervals.
2. Stow the maintenance stand and fully lower the platform.

Limit Switch Cam Setup

1. Turn the emergency main power disconnect switch to the ON position.
2. Attach the end of a measuring tape to the side of the platform with a tie wrap, in such a way that the measuring tape will hang down freely to the ground. **Note:** The end of the measuring tape should be level with the standing surface of the platform.
3. **For High Speed Cutout Limit Switches:** Raise the platform until the distance from the standing surface of the platform to the ground measures 96".
4. Loosen the set screws (x2) on the High Speed limit switch cam, and then rotate the cam until it depresses the limit switch plunger and a click is heard inside the limit switch. Repeat this step for the other high speed limit switch.

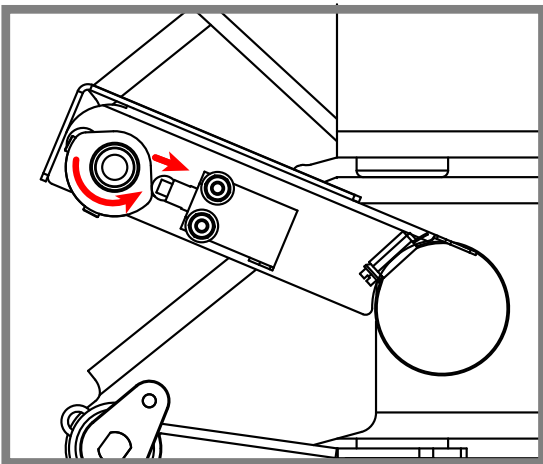

5. **For Drive Override Limit Switch:** Place a block, approximately 1.5" (3.75 cm), under the hydraulic/ electric tray and then raise the platform to an approximate height of 7 feet (2 meters) or until the pothole protection is activated.
6. Loosen the set screws (x2) on the Drive Override limit switch cam, and rotate the cam until it depresses the limit switch plunger and a click is heard inside the limit switch.

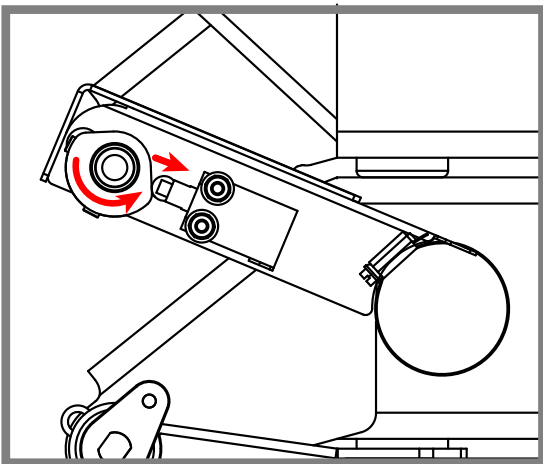

7. Fully lower the platform.

Limit Switch Testing

1. **For High Speed Cutout Limit Switch:** Raise the platform less than 93", and drive the unit at full speed. The unit should move at high speed. Then raise the platform over 93". The unit should automatically switch from high speed to low speed. **Note:** High Speed Cutout should occur within the tolerance zone of 93" to 99".
2. **For Drive Override Limit Switch:** Place a block, approximately 1.5" (3.75 cm), under the hydraulic/ electric tray and then raise the platform to an approximate height of 7 feet (2 meters) or until the pothole protection is activated. Attempt to drive forward or reverse. Aerial platform should not move forward or backward.

Section 6 - APPENDIX A

Motor Controller Option

This section is based on Serial Number(s):

SJIII 3220 60 004 852 & Above

SJIII 3226 27 021 943 & Above

SJIII 46xx 70 021 720 & Above

Please refer to the website www.skyjack.com for older Serial Numbers.

Section 6 - APPENDIX A

Parts List

6.1 Electrical Component Parts List.....	146
--	-----

Diagrams and Schematics

6.2 Platform Control Console Diagram.....	147
6.3 Scissor Assembly Limit Switches	148
6.4a Electrical Panel Diagram - Motor Controller	150
6.4b Electrical Panel Diagram - Motor Controller	151
6.4c Electrical Panel Diagram - Motor Controller	152
6.5a Electrical Panel Diagram Powerdeck - Motor Controller	153
6.5b Electrical Panel Diagram Powerdeck - Motor Controller	154
6.5c Electrical Panel Diagram Powerdeck - Motor Controller	155
6.6a Electrical Panel Diagram - Motor Controller - Inverter Option.....	156
6.6b Electrical Panel Diagram - Motor Controller - Inverter Option.....	157
6.6c Electrical Panel Diagram - Motor Controller - Inverter Option.....	158
6.7a Electrical Panel Diagram Powerdeck - Motor Controller - Inverter Option.....	159
6.7b Electrical Panel Diagram Powerdeck - Motor Controller - Inverter Option	160
6.7c Electrical Panel Diagram Powerdeck - Motor Controller - Inverter Option.....	161
6.8 Main Manifold Harness - Motor Controller	162
6.9 Hydraulic Schematic (Models 32XX) - Motor Controller	163
6.10a Hydraulic Schematic (Models 46XX) - Motor Controller	164
6.10b Hydraulic Schematic (Models 46XX) - Motor Controller	165
6.11a Electrical Schematic - Motor Controller	167
6.11b Electrical Schematic - Motor Controller.....	168
6.11c Electrical Schematic - Motor Controller	169

Troubleshooting

Introduction - Troubleshooting	170
--------------------------------------	-----

Electrical System

6.12-1 All Controls Inoperative.....	171
6.12-2 All Controls Except for Down Function Inoperative	172
6.12-3 All Controls Inoperative From Base Control Console	172
6.12-4 No Up Function from Base Control Console.....	172
6.12-5 Up Function Slow from Base Control Console	173
6.12-6 No Down Function from Base Control Console	173
6.12-7 All Controls Inoperative From Platform Control Console.....	174
6.12-8 No Up Function from Platform Controls.....	174
6.12-9 Up Function Slow from Platform Control Console	175
6.12-10 No Down Function from Platform Controls	175
6.12-11 Steer Only Inoperative	175
6.12-12 Right Steer Inoperative (Without power deck option).....	176
6.12-13 Right Steer Inoperative (With power deck option)	176
6.12-14 Left Steer Inoperative (Without power deck option)	176
6.12-15 Left Steer Inoperative (With power deck option).....	177
6.12-16 Drive Only Inoperative	177
6.12-17 No Drive or Steer when Platform Fully Lowered	177
6.12-18 No Drive or Steer when Platform Elevated	177
6.12-19 Platform Drives in Slow Speed Only.....	178
6.12-20 High/Low Torque Inoperative.....	178

6.12-21 Brake will not Release.....178
 6.12-22 Forward Drive Function Inoperative178
 6.12-23 Reverse Drive Function Inoperative.....179
 6.12-24 Power Extension Platform will not Extend or Retract.....179
 6.12-25 Power Extension Platform will not Extend179

Hydraulic System

6.12-26 Power Extension Platform will not Retract.....180
 6.13-1 All Function Inoperative180
 6.13-2 All System sluggish180
 6.13-3 Platform Drifts Down180
 6.13-4 Platform Lifts Slowly.....180
 6.13-5 Platform does not Lift.....181
 6.13-6 Platform will not Lower.....181
 6.13-7 Platform Drives Slow.....181
 6.13-8 Platform will not Drive in Forward or Reverse181
 6.13-9 Brake(s) will not Release (Pin brakes).....181
 6.13-10 Brake(s) will not Release (Integral brakes).....181

Procedure

6.13-11 Aerial Platform will not hold on a Grade (Integral brakes)182
 6.13-12 Platform does not Steer182
 6.13-13 Power Extension Platform will not Extend or Retract.....182
 6.13-14 High/Low Torque Inoperative.....182
 General.....183
 Safety and Workmanship.....183

Platform

6.14-1 OEM Controller Electronics Information183
 6.14-2 OEM Controller Troubleshooting184
 6.14-3 OEM Controller Switch Wiring185
 6.14-4 Gate Spring Hinge Adjustment186

Base

6.15-3 Resistor - Voltage Divider188

AK

6.1 Electrical Component Parts List

Index No.	Skyjack Part No.	Qty.	Description
21CR	108589	1	RELAY, 24 Volt (Cushion)
14CR	108589	1	RELAY, 24 Volt (Lift Speed)
14CR1	108589	1	RELAY, 24 Volt (Lift Speed 2)
59JCR	108589	1	RELAY, 24 Volt (Base Control)
9ACR-1	108589	1	RELAY, 24 Volt (Powerdeck Relay #1)
9ACR	108589	1	RELAY, 24 Volt (Powerdeck Relay #2)
RST1	119629	1	RESISTOR (2.7K ohm)
RST2	166243	1	WIRE, Motor Controller (6.25" / 68 OHM)
	151647	1	• RESISTOR, (68 ohm)
RST3	169102	1	WIRE, Motor Controller (6.75" / 360 OHM)
	168987	1	• RESISTOR, (360 ohm)
RST4	166244	1	WIRE, Motor Controller (5.25" / 68 OHM)
	151647	1	• RESISTOR, (68 ohm)
RST5	166245	1	WIRE, Motor Controller (5.25" / 4.75 KOHM)
	151645	1	• RESISTOR, (4.75k ohm)
RST6	198792	1	WIRE, Motor Controller (5.25" / 1.2 KOHM)
	163253	1	• RESISTOR, (1.2k ohm)
RST7	151643	1	RESISTOR, (250 ohm)
RST8	156564	1	RESISTOR, (1.5 ohm)
LS4	166007	1	LIMIT SWITCH, Pothole protection (Battery tray) (For model 3220 with serial number 60007077 & Below) (For model 3226 with serial number 27032454 & Below) (For model 46xx with serial number 70032133 & Below)
	199745	1	LIMIT SWITCH, Pothole protection (Battery tray) (For model 3220 with serial number 60007078 & Above) (For model 3226 with serial number 27032455 & Above) (For model 46xx with serial number 70032134 & Above)
LS5	133600	1	LIMIT SWITCH, Pothole protection (Hydraulic tray) (For model 3220 with serial number 60007077 & Below) (For model 3226 with serial number 27032454 & Below) (For model 46xx with serial number 70032133 & Below)
	199459	1	LIMIT SWITCH, Pothole protection (Hydraulic tray) (For model 3220 with serial number 60007078 & Above) (For model 3226 with serial number 27032455 & Above) (For model 46xx with serial number 70032134 & Above)
S7	159111	1	JOYSTICK, Motor Controller
S7-1	122869	1	SWITCH, Neutral
S7-2	159613	1	SWITCH, Right Steer
S7-3	159613	1	SWITCH, Left Steer
S7-6	159067	1	SWITCH, Pushbutton - Enable
TIMER	137417	1	TIMER, Relay - Delay-On-Release
TT	195940	1	HOURMETER, Digital

6.2 Platform Control Console Diagram

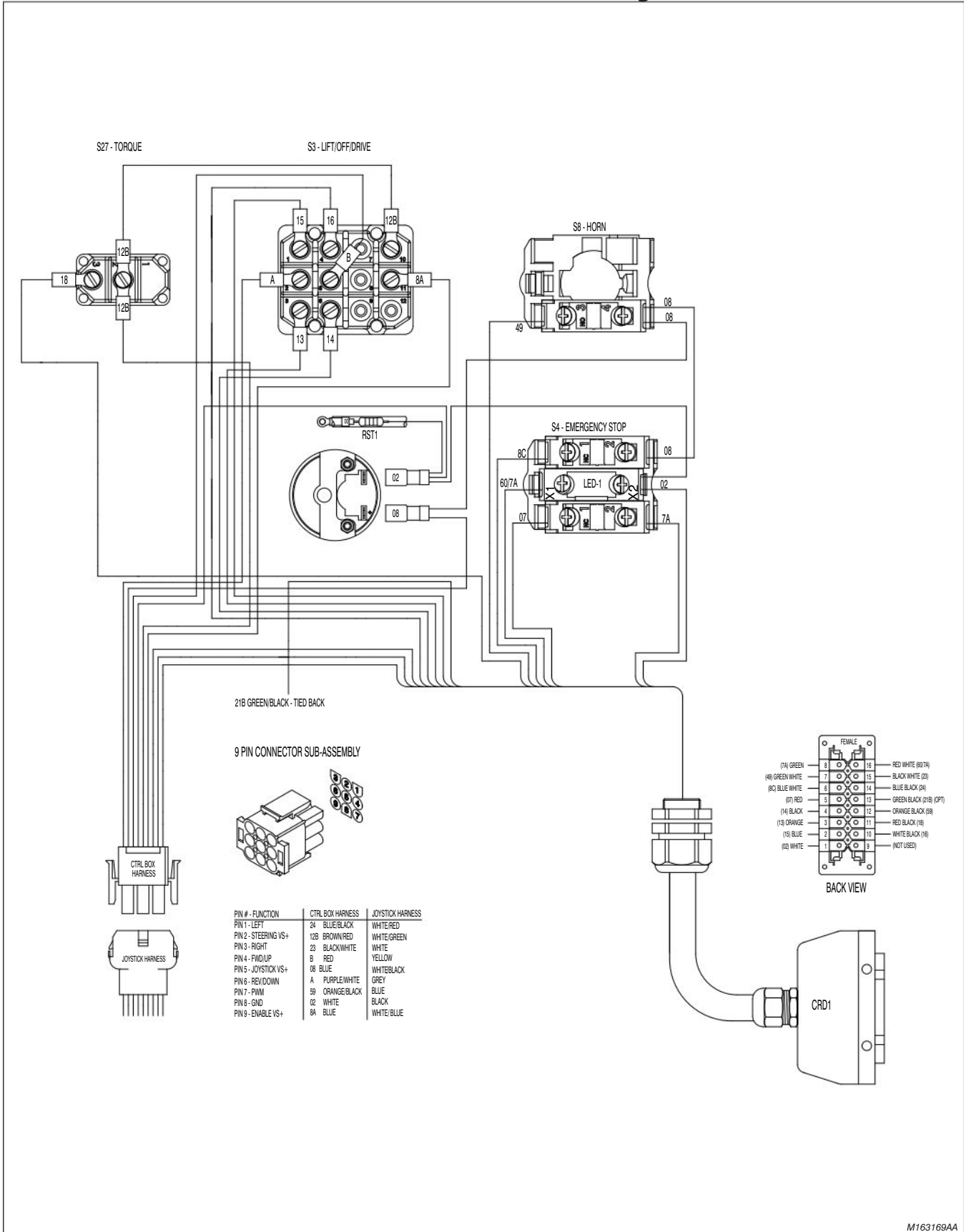

M163169AA

AK

6.3 Scissor Assembly Limit Switches

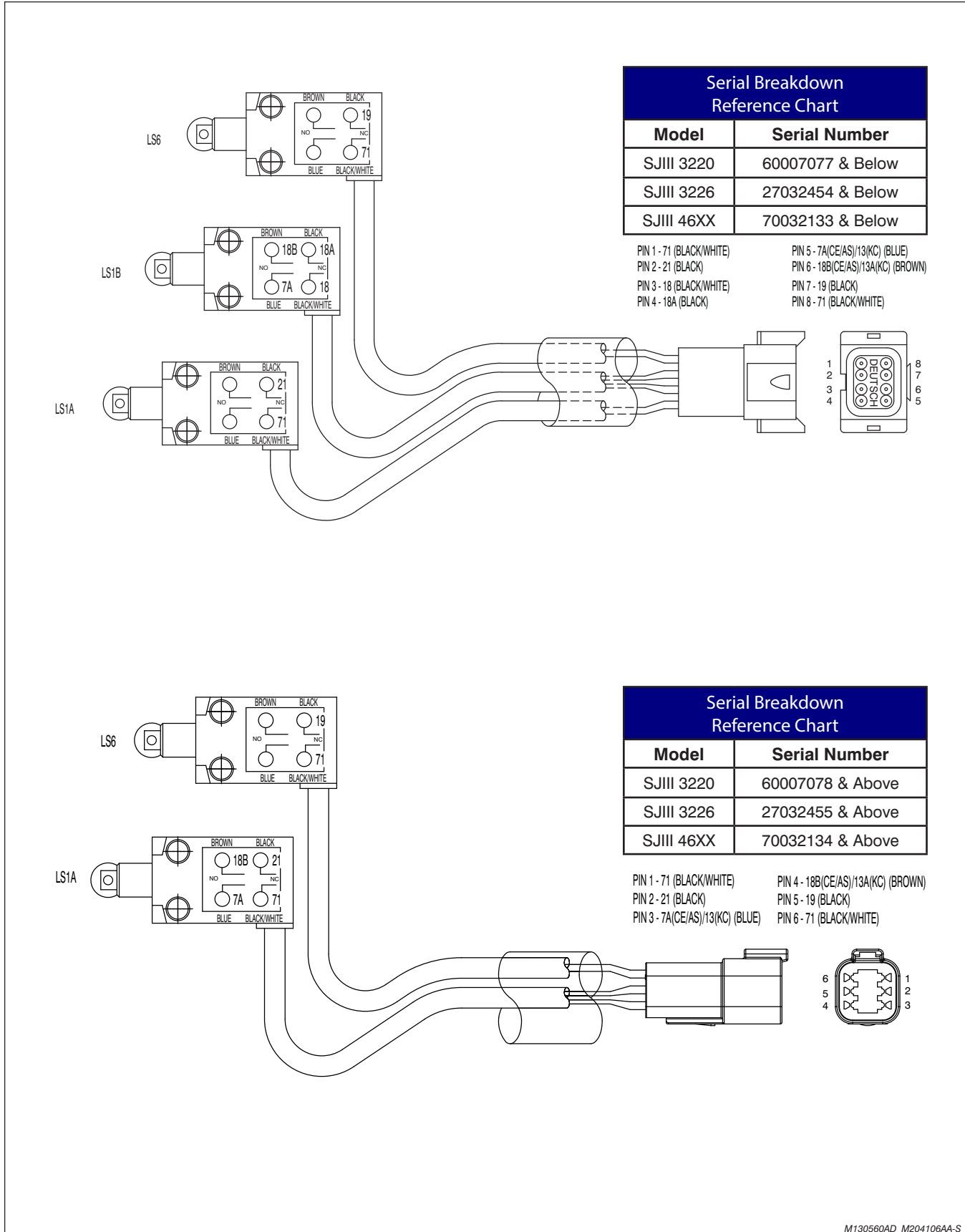

M130560AD_M204106AA-S

Notes

[Empty rectangular box for notes]

6.4a Electrical Panel Diagram - Motor Controller

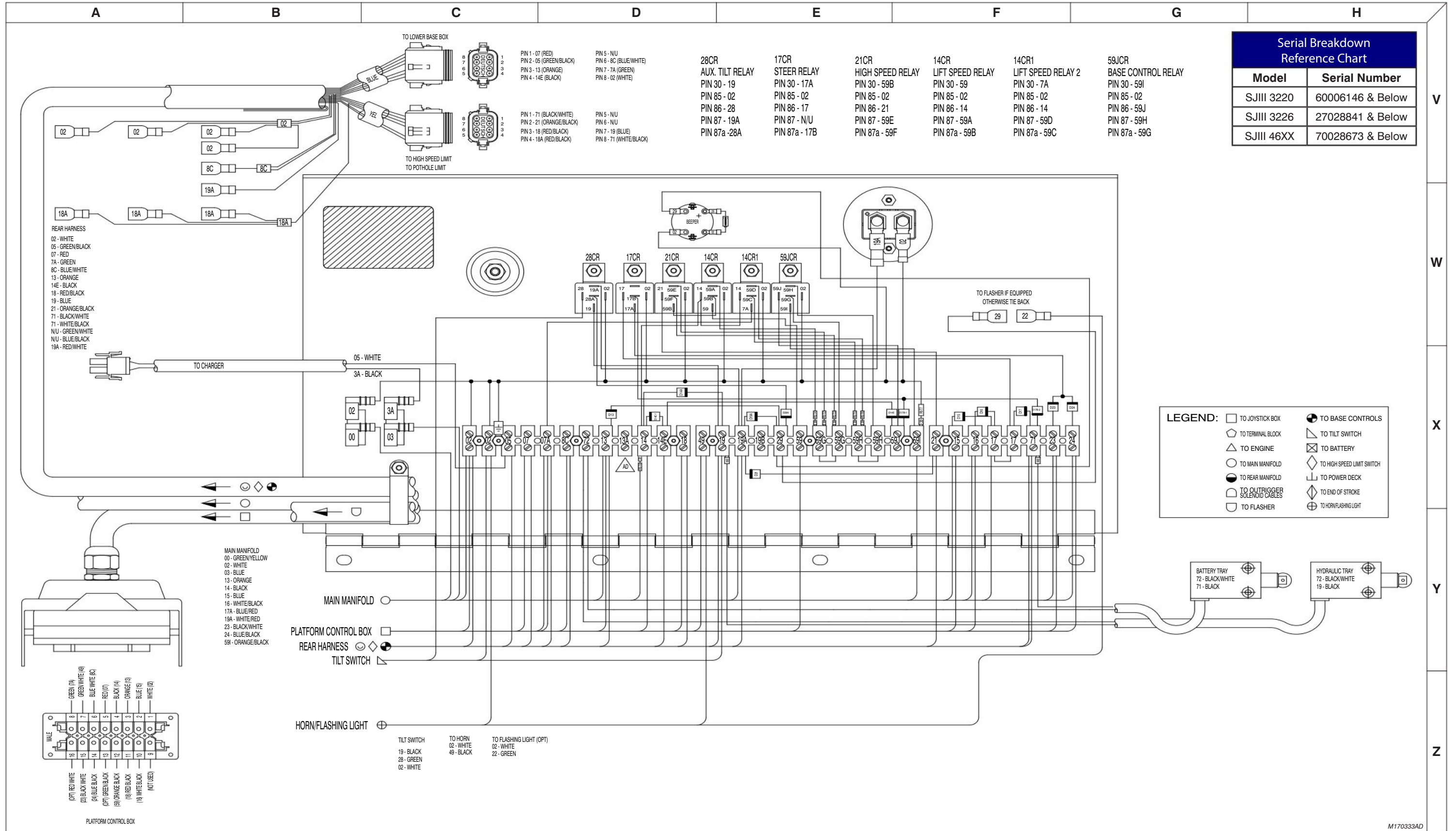

6.4b Electrical Panel Diagram - Motor Controller

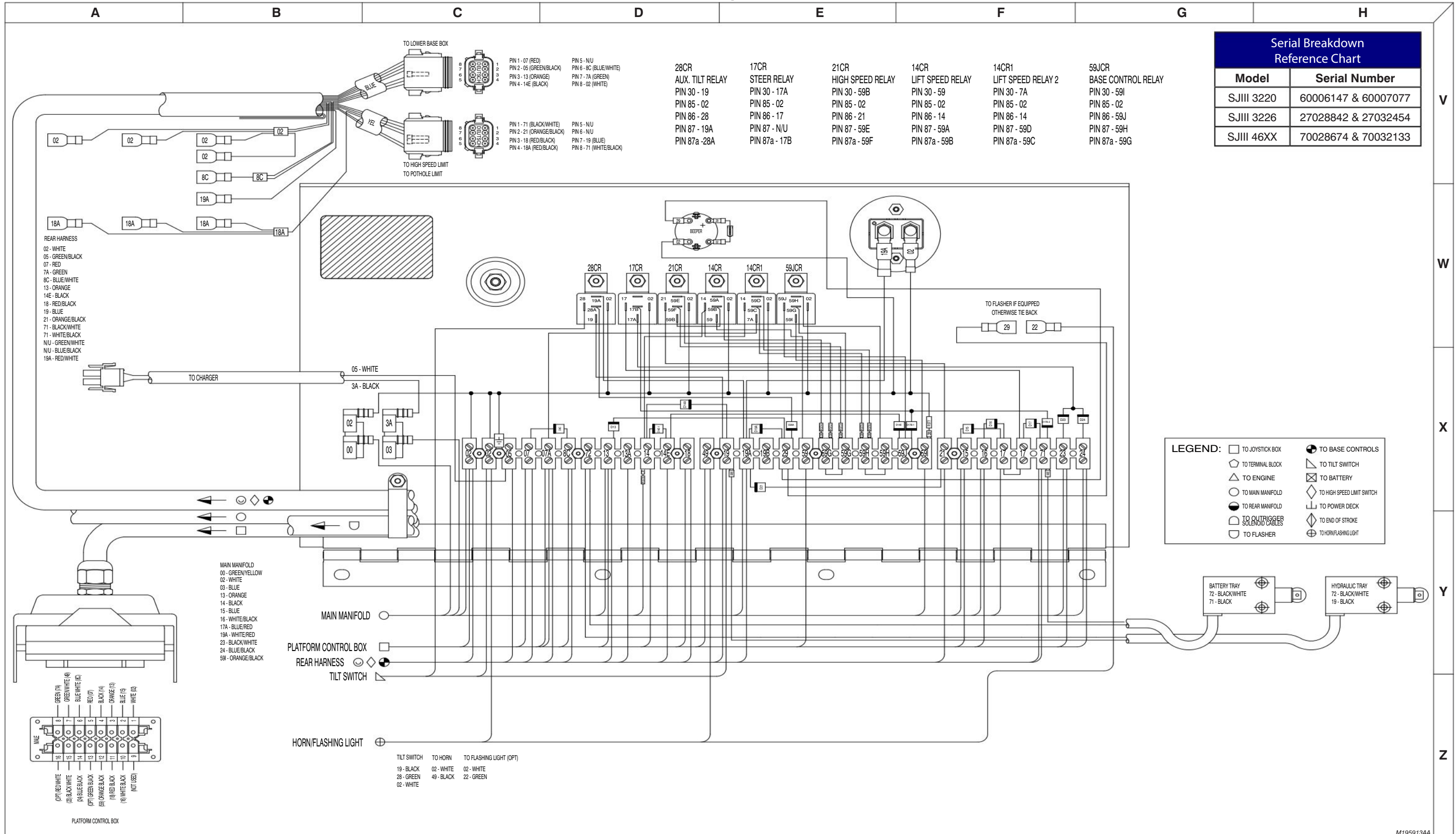

6.4c Electrical Panel Diagram - Motor Controller

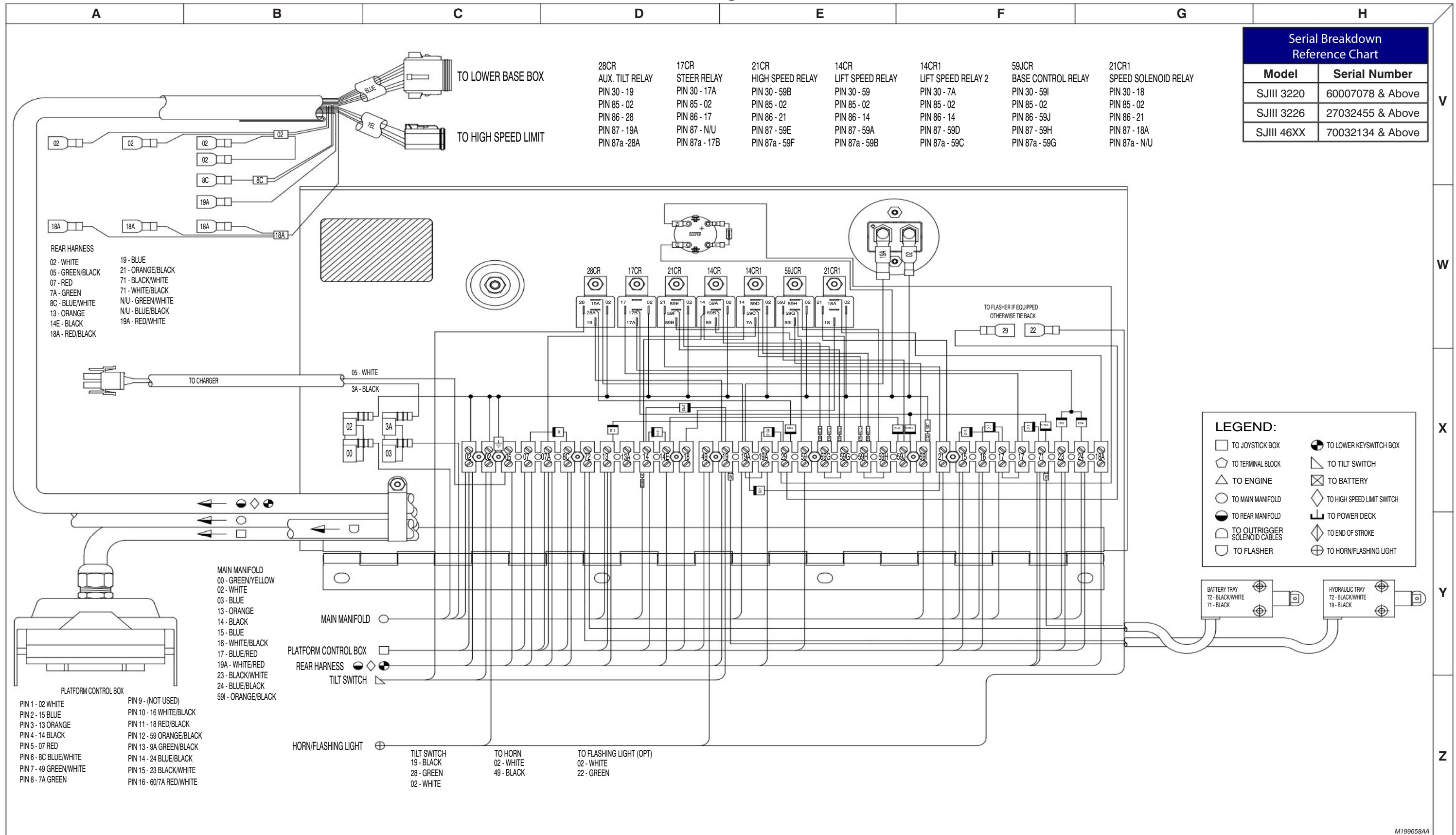

Serial Breakdown Reference Chart	
Model	Serial Number
SJIII 3220	60007078 & Above
SJIII 3226	27032455 & Above
SJIII 46XX	70032134 & Above

Relay	Function	Pin 1	Pin 2	Pin 3	Pin 4	Pin 5	Pin 6	Pin 7	Pin 8
28CR	AUX. TILT RELAY	PIN 30 - 19	PIN 85 - 02	PIN 86 - 28	PIN 87 - 19A	PIN 87a - 28A			
17CR	STEER RELAY	PIN 30 - 17A	PIN 85 - 02	PIN 86 - 17	PIN 87 - N/U	PIN 87a - 17B			
21CR	HIGH SPEED RELAY	PIN 30 - 59B	PIN 85 - 02	PIN 86 - 21	PIN 87 - 59E	PIN 87a - 59F			
14CR	LIFT SPEED RELAY	PIN 30 - 59	PIN 85 - 02	PIN 86 - 14	PIN 87 - 59A	PIN 87a - 59B			
14CR1	LIFT SPEED RELAY 2	PIN 30 - 7A	PIN 85 - 02	PIN 86 - 14	PIN 87 - 59D	PIN 87a - 59C			
59JCR	BASE CONTROL RELAY	PIN 30 - 59I	PIN 85 - 02	PIN 86 - 59J	PIN 87 - 59H	PIN 87a - 59G			
21CR1	SPEED SOLENOID RELAY	PIN 30 - 18	PIN 85 - 02	PIN 86 - 21	PIN 87 - 18A	PIN 87a - N/U			

- REAR HARNESS**
- 02 - WHITE
 - 05 - GREEN/BLACK
 - 07 - RED
 - 7A - GREEN
 - 8C - BLUE/WHITE
 - 13 - ORANGE
 - 14E - BLACK
 - 18A - RED/BLACK
 - 19 - BLUE
 - 21 - ORANGE/BLACK
 - 71 - BLACK/WHITE
 - 71 - WHITE/BLACK
 - N/U - GREEN/WHITE
 - N/U - BLUE/BLACK
 - 19A - RED/WHITE

- MAIN MANIFOLD**
- 00 - GREEN/YELLOW
 - 02 - WHITE
 - 03 - BLUE
 - 13 - ORANGE
 - 14 - BLACK
 - 15 - BLUE
 - 16 - WHITE/BLACK
 - 17 - BLUE/RED
 - 19A - WHITE/RED
 - 23 - BLACK/WHITE
 - 24 - BLUE/BLACK
 - 59I - ORANGE/BLACK

- PLATFORM CONTROL BOX**
- PIN 1 - 02 WHITE
 - PIN 2 - 15 BLUE
 - PIN 3 - 13 ORANGE
 - PIN 4 - 14 BLACK
 - PIN 5 - 07 RED
 - PIN 6 - 8C BLUE/WHITE
 - PIN 7 - 49 GREEN/WHITE
 - PIN 8 - 7A GREEN
 - PIN 9 - (NOT USED)
 - PIN 10 - 16 WHITE/BLACK
 - PIN 11 - 18 RED/BLACK
 - PIN 12 - 59 ORANGE/BLACK
 - PIN 13 - 9A GREEN/BLACK
 - PIN 14 - 24 BLUE/BLACK
 - PIN 15 - 23 BLACK/WHITE
 - PIN 16 - 60/7A RED/WHITE

- PLATFORM CONTROL BOX**
- REAR HARNESS
 - TILT SWITCH
 - HORN/FLASHING LIGHT

- TILT SWITCH**
- 19 - BLACK
 - 28 - GREEN
 - 02 - WHITE
- TO HORN**
- 02 - WHITE
 - 49 - BLACK
- TO FLASHING LIGHT (OPT)**
- 02 - WHITE
 - 22 - GREEN

LEGEND:

□ TO JOYSTICK BOX	⊕ TO LOWER KEYSWITCH BOX
◇ TO TERMINAL BLOCK	△ TO TILT SWITCH
△ TO ENGINE	⊗ TO BATTERY
○ TO MAIN MANIFOLD	◇ TO HIGH SPEED LIMIT SWITCH
● TO REAR MANIFOLD	⌋ TO POWER DECK
⊖ TO OUTTRIGGER SOLENOID CABLES	◇ TO END OF STROKE
⊖ TO FLASHER	⊕ TO HORN/FLASHING LIGHT

M199658AA

6.5a Electrical Panel Diagram Powerdeck - Motor Controller

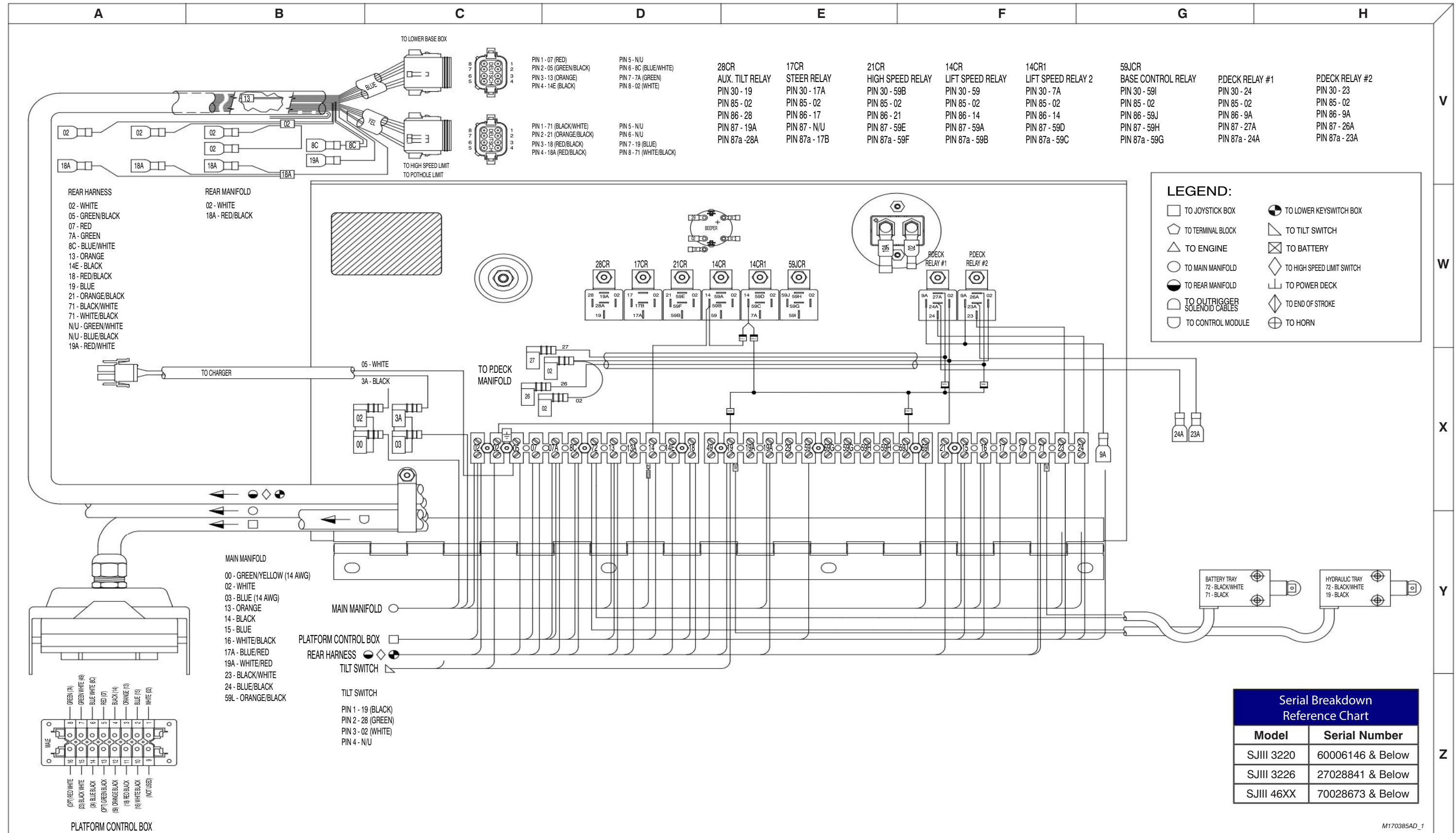

6.5b Electrical Panel Diagram Powerdeck - Motor Controller

AI

Serial Breakdown Reference Chart	
Model	Serial Number
SJIII 3220	60006147 & 60007077
SJIII 3226	27028842 & 27032454
SJIII 46XX	70028674 & 70032133

V

28CR AUX. TILT RELAY PIN 30 - 19 PIN 85 - 02 PIN 86 - 28 PIN 87 - 19A PIN 87a - 28A	17CR STEER RELAY PIN 30 - 17A PIN 85 - 02 PIN 86 - 17 PIN 87 - N/U PIN 87a - 17B	21CR HIGH SPEED RELAY PIN 30 - 59B PIN 85 - 02 PIN 86 - 21 PIN 87 - 59E PIN 87a - 59F	14CR LIFT SPEED RELAY PIN 30 - 59 PIN 85 - 02 PIN 86 - 14 PIN 87 - 59A PIN 87a - 59B	14CR1 LIFT SPEED RELAY 2 PIN 30 - 7A PIN 85 - 02 PIN 86 - 14 PIN 87 - 59D PIN 87a - 59C	59JCR BASE CONTROL RELAY PIN 30 - 59I PIN 85 - 02 PIN 86 - 59J PIN 87 - 59H PIN 87a - 59G	PDECK RELAY #1 PIN 30 - 24 PIN 85 - 02 PIN 86 - 9A PIN 87 - 27A PIN 87a - 24A	PDECK RELAY #2 PIN 30 - 23 PIN 85 - 02 PIN 86 - 9A PIN 87 - 26A PIN 87a - 23A
---	--	---	--	---	---	--	--

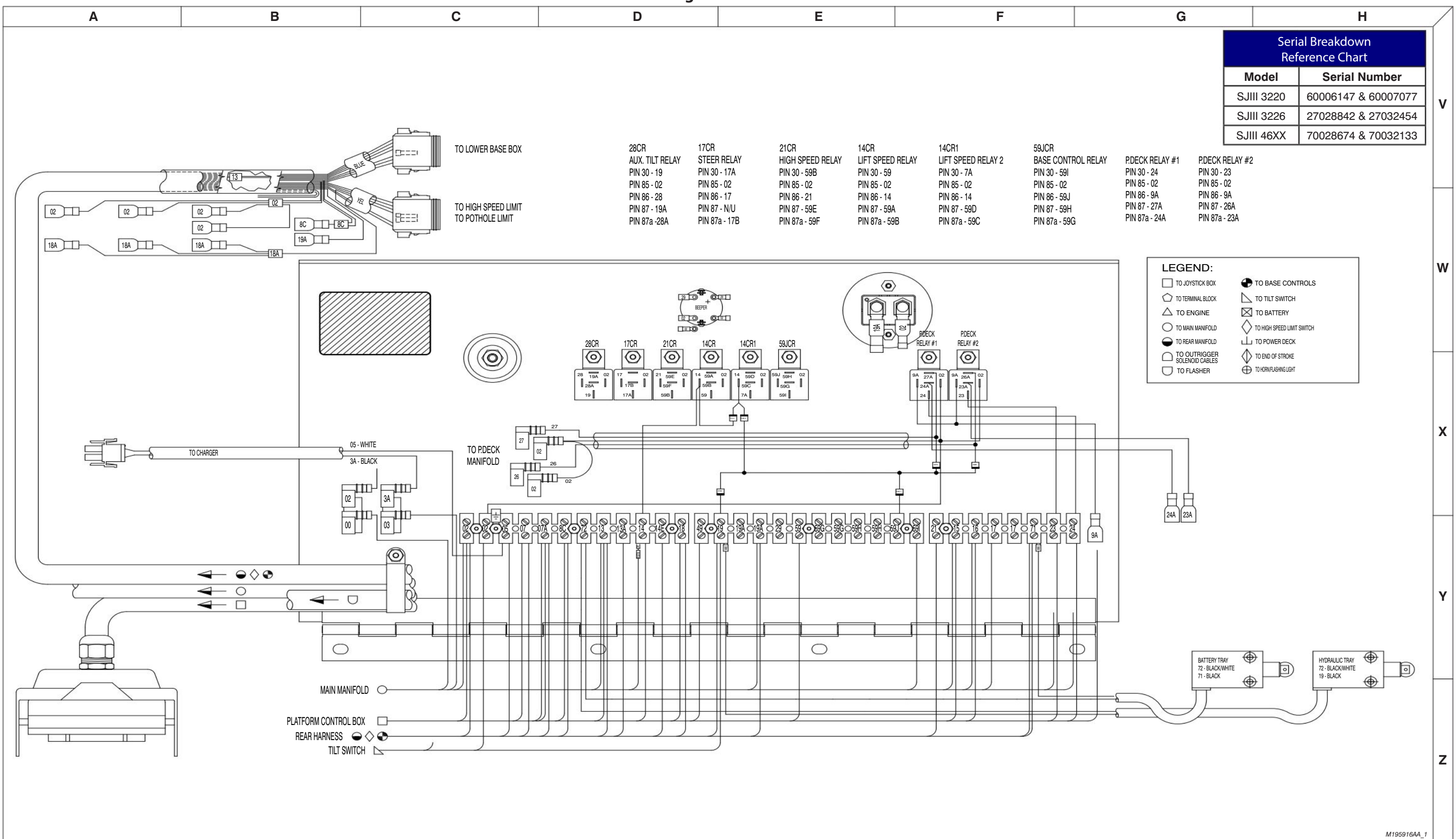

LEGEND:

- TO JOYSTICK BOX
- TO TERMINAL BLOCK
- △ TO ENGINE
- TO MAIN MANIFOLD
- ⊖ TO REAR MANIFOLD
- ⊕ TO OUTRIGGER SOLENOID CABLES
- ⊖ TO FLASHER
- TO BASE CONTROLS
- △ TO TILT SWITCH
- ⊖ TO BATTERY
- ◇ TO HIGH SPEED LIMIT SWITCH
- ⊖ TO POWER DECK
- ◇ TO END OF STROKE
- ⊕ TO HORN/FLASHING LIGHT

W

X

Y

Z

M195916AA_1

6.5c Electrical Panel Diagram Powerdeck - Motor Controller

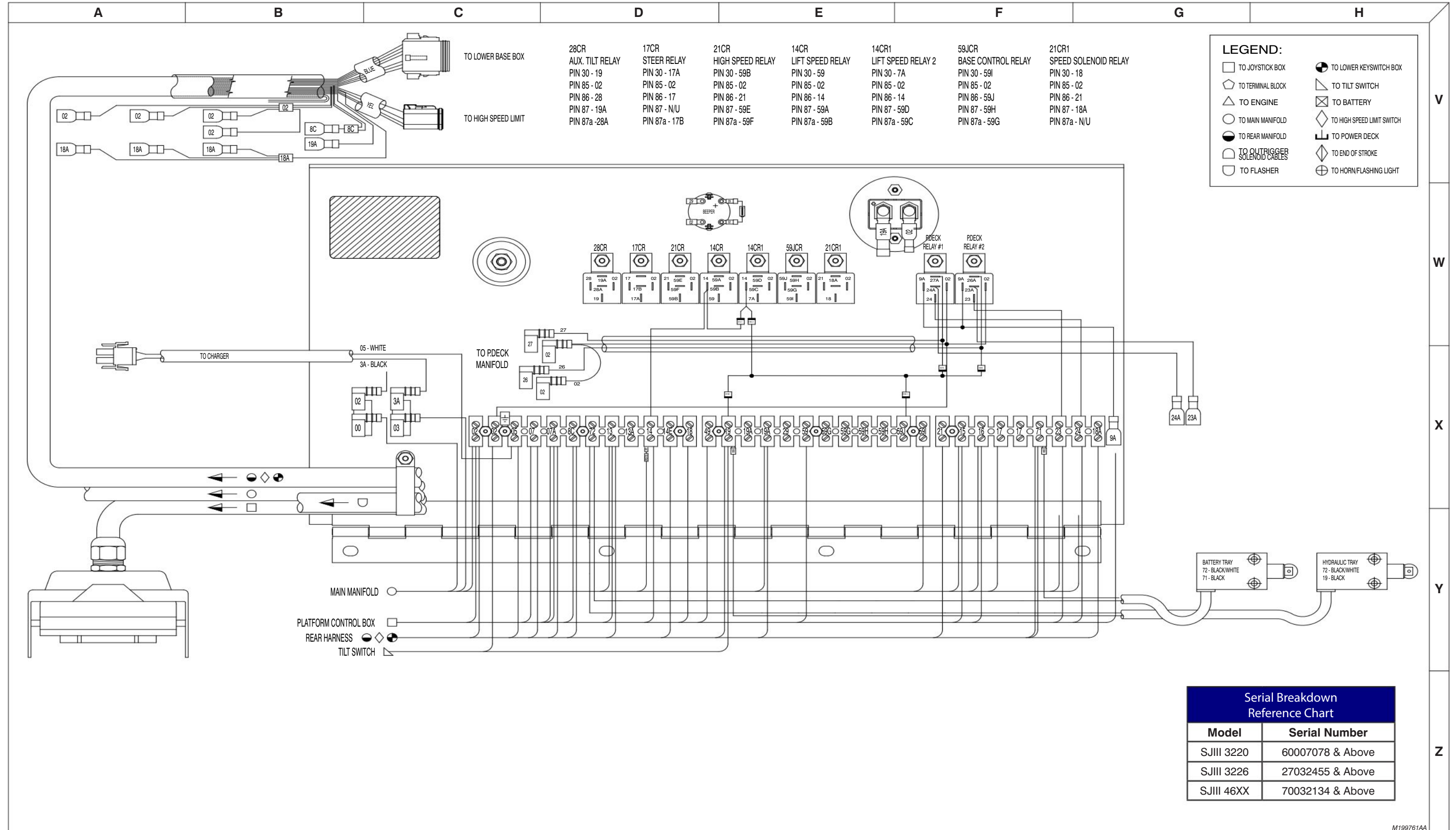

6.6a Electrical Panel Diagram - Motor Controller - Inverter Option

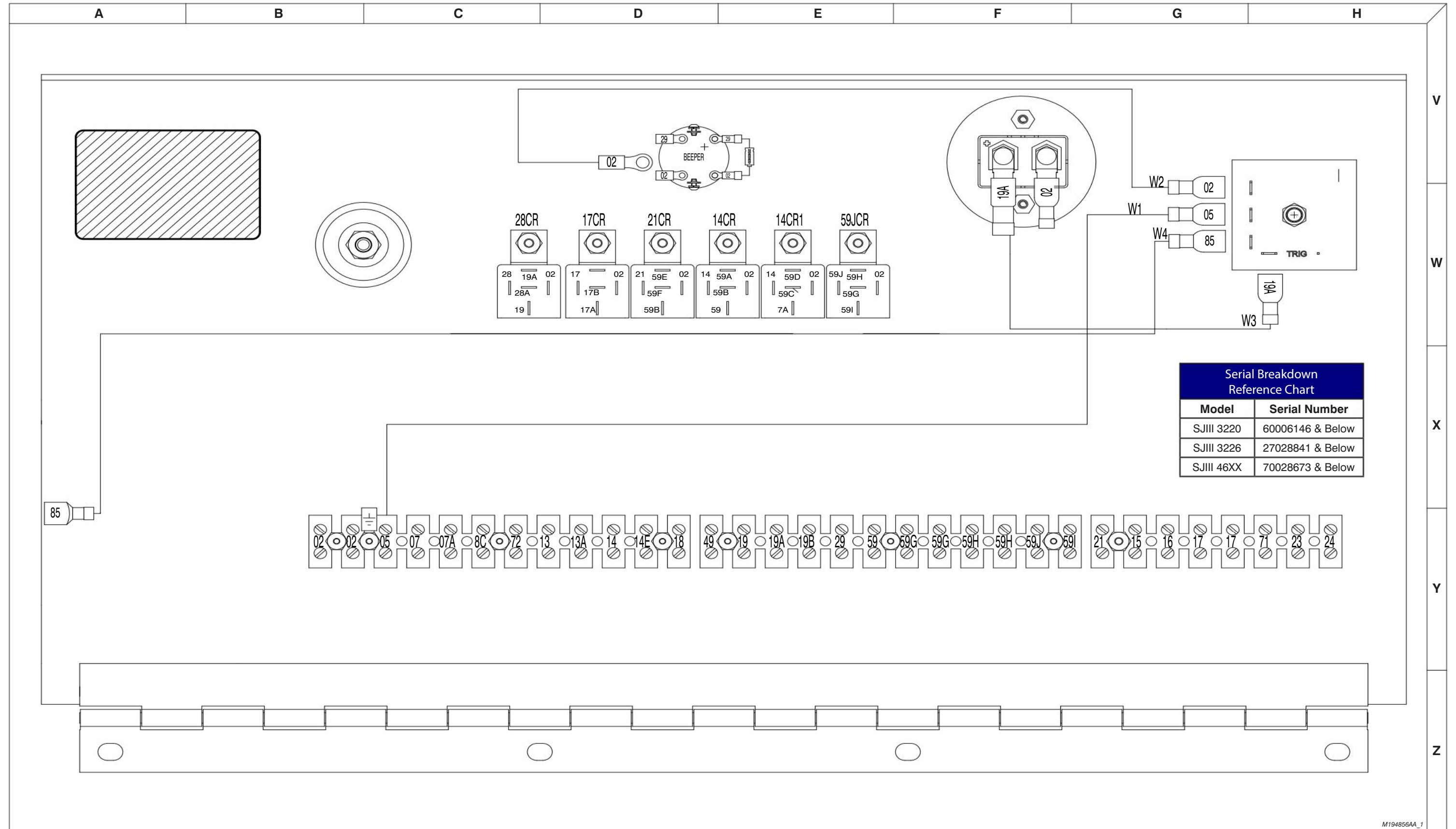

Serial Breakdown Reference Chart	
Model	Serial Number
SJIII 3220	60006146 & Below
SJIII 3226	27028841 & Below
SJIII 46XX	70028673 & Below

6.6b Electrical Panel Diagram - Motor Controller - Inverter Option

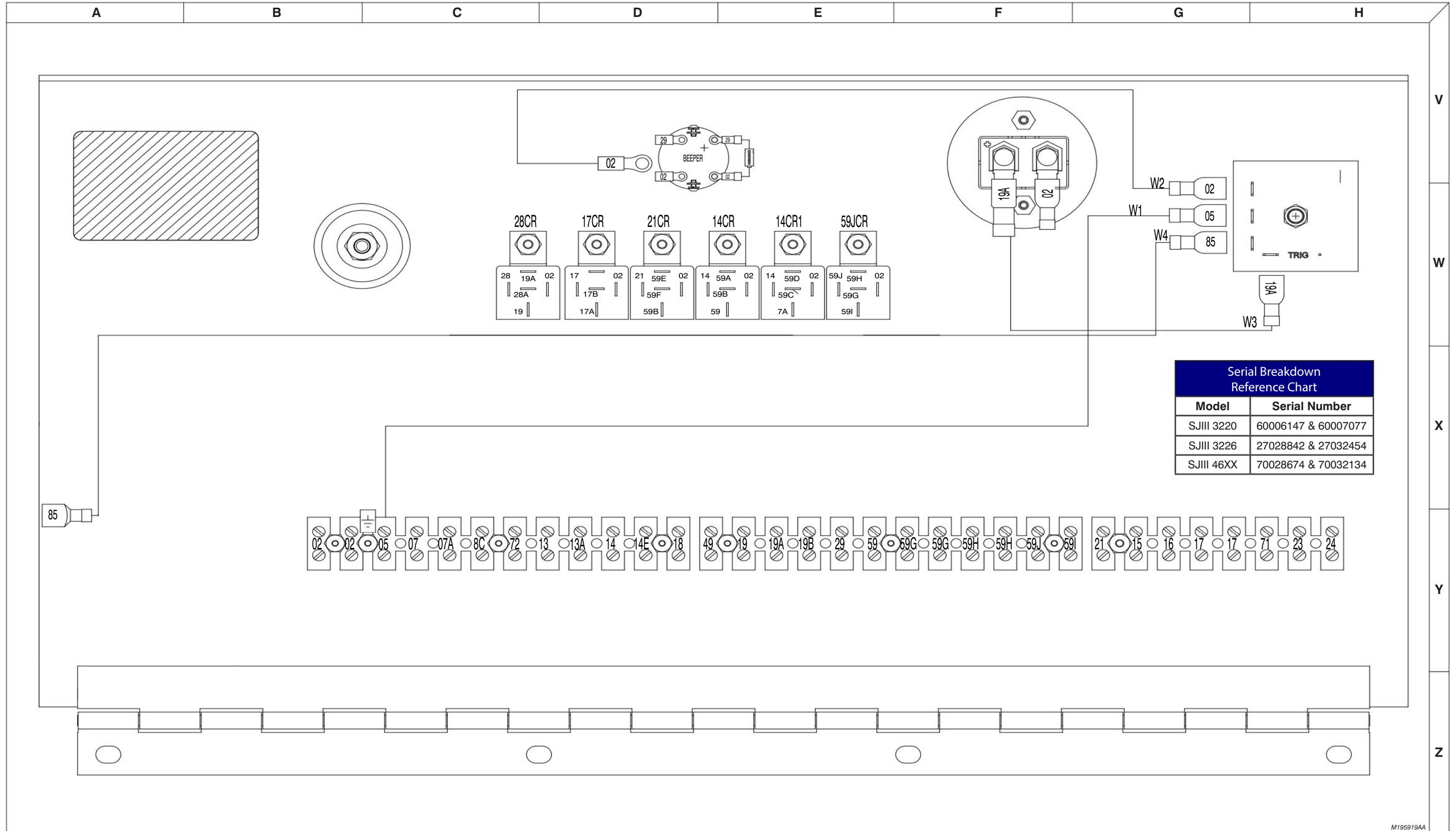

Serial Breakdown Reference Chart	
Model	Serial Number
SJIII 3220	60006147 & 60007077
SJIII 3226	27028842 & 27032454
SJIII 46XX	70028674 & 70032134

M195919AA

6.6c Electrical Panel Diagram - Motor Controller - Inverter Option

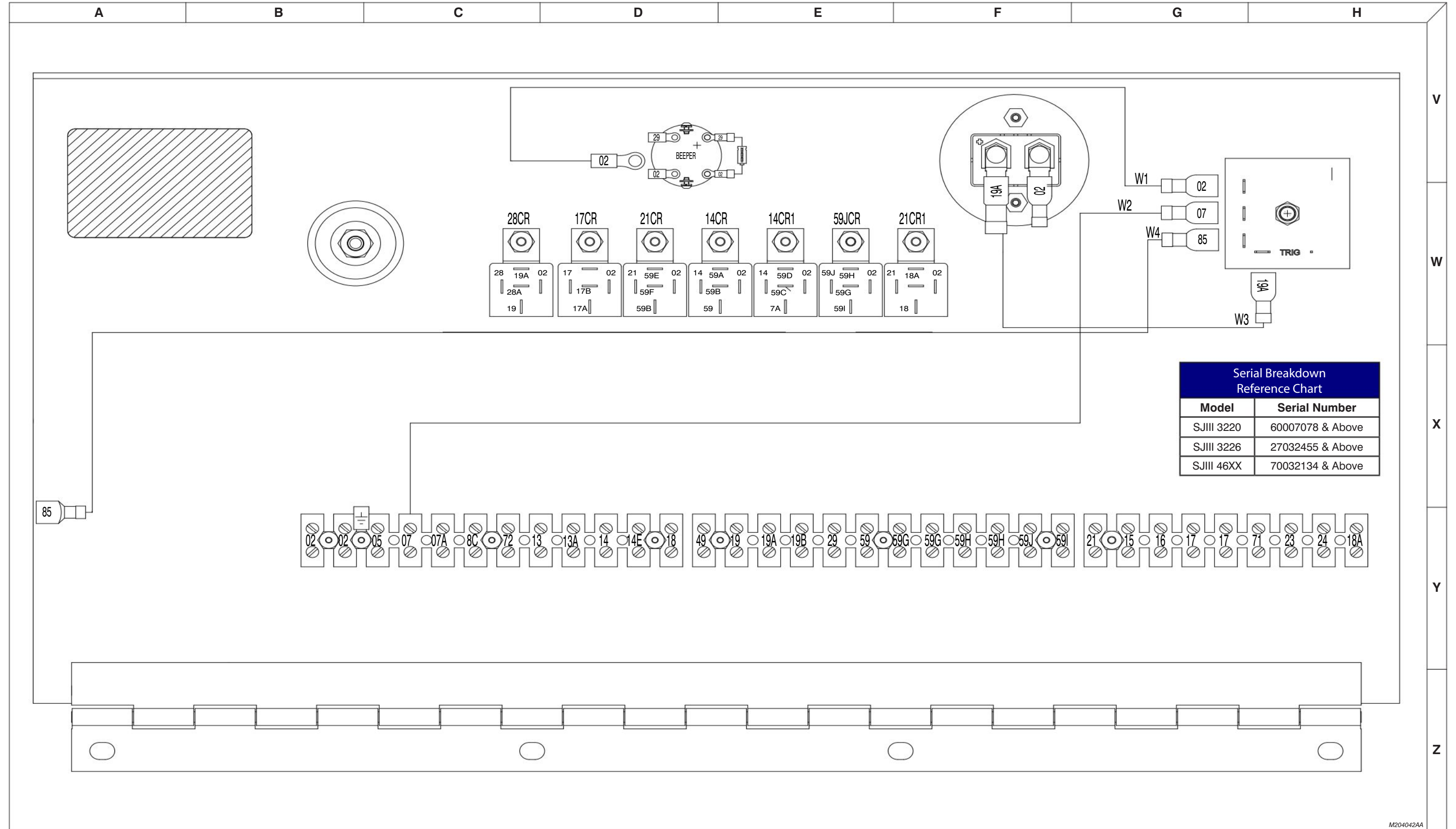

6.7a Electrical Panel Diagram Powerdeck - Motor Controller - Inverter Option

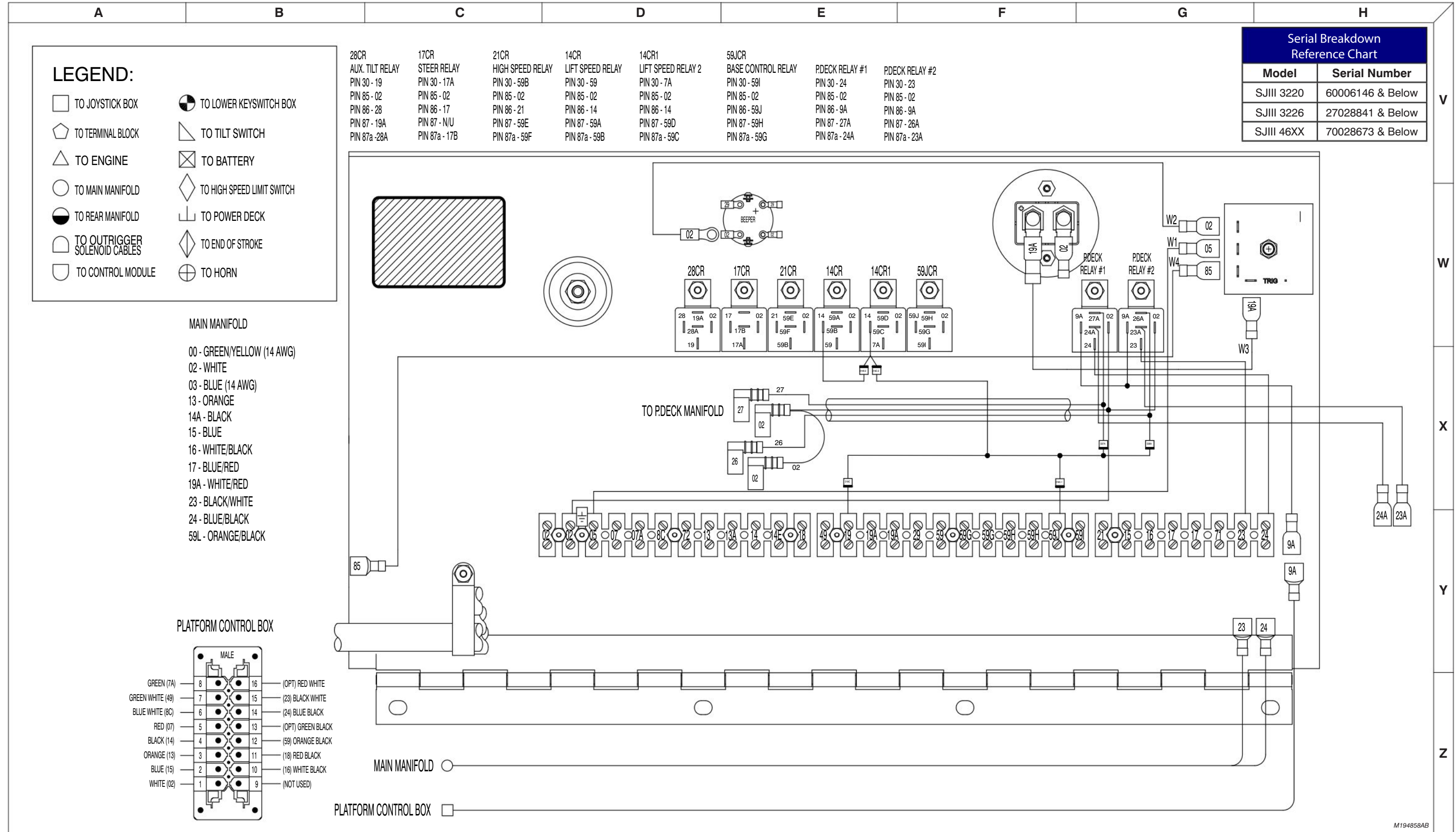

6.7b Electrical Panel Diagram Powerdeck - Motor Controller - Inverter Option

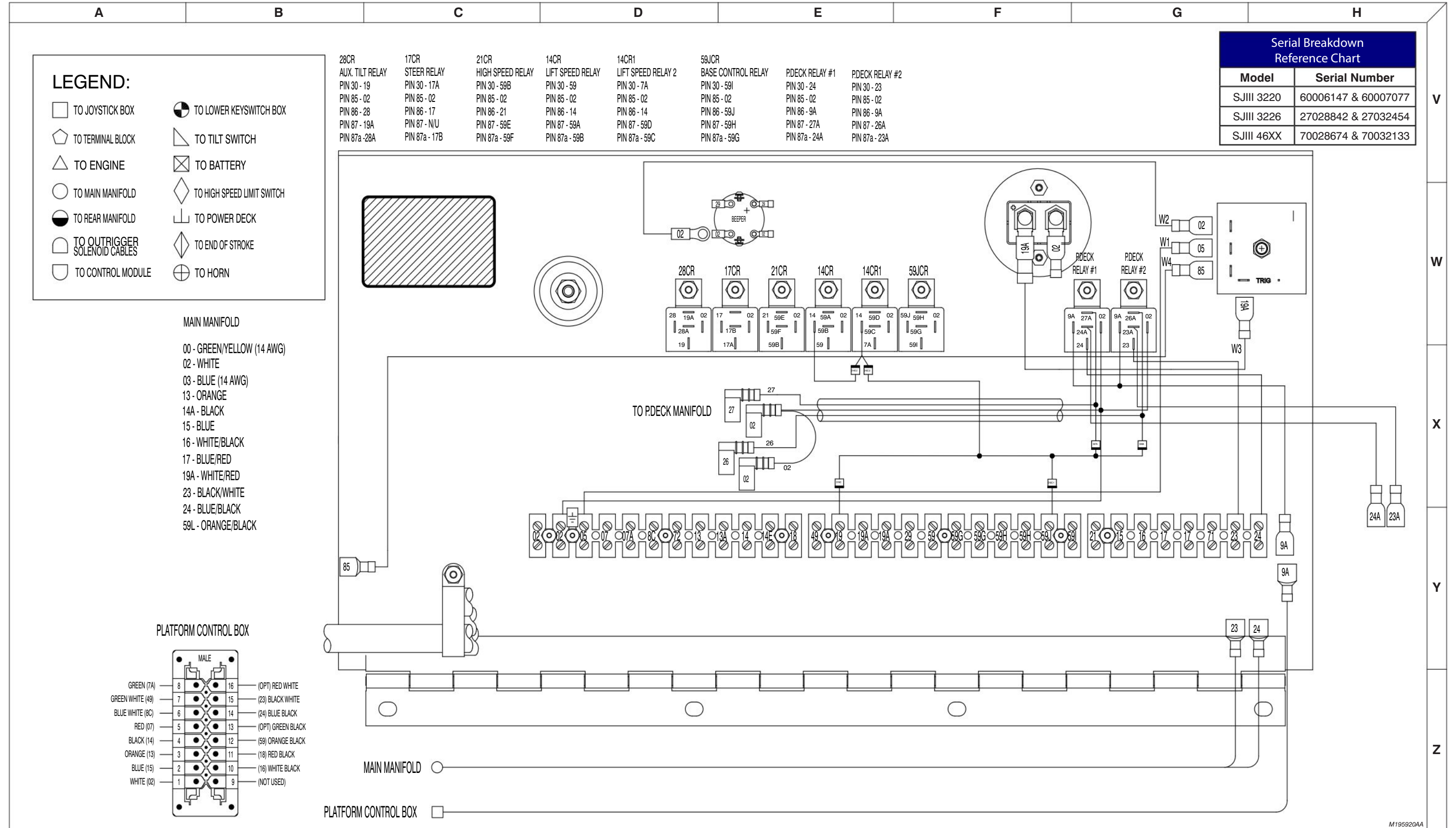

6.7c Electrical Panel Diagram Powerdeck - Motor Controller - Inverter Option

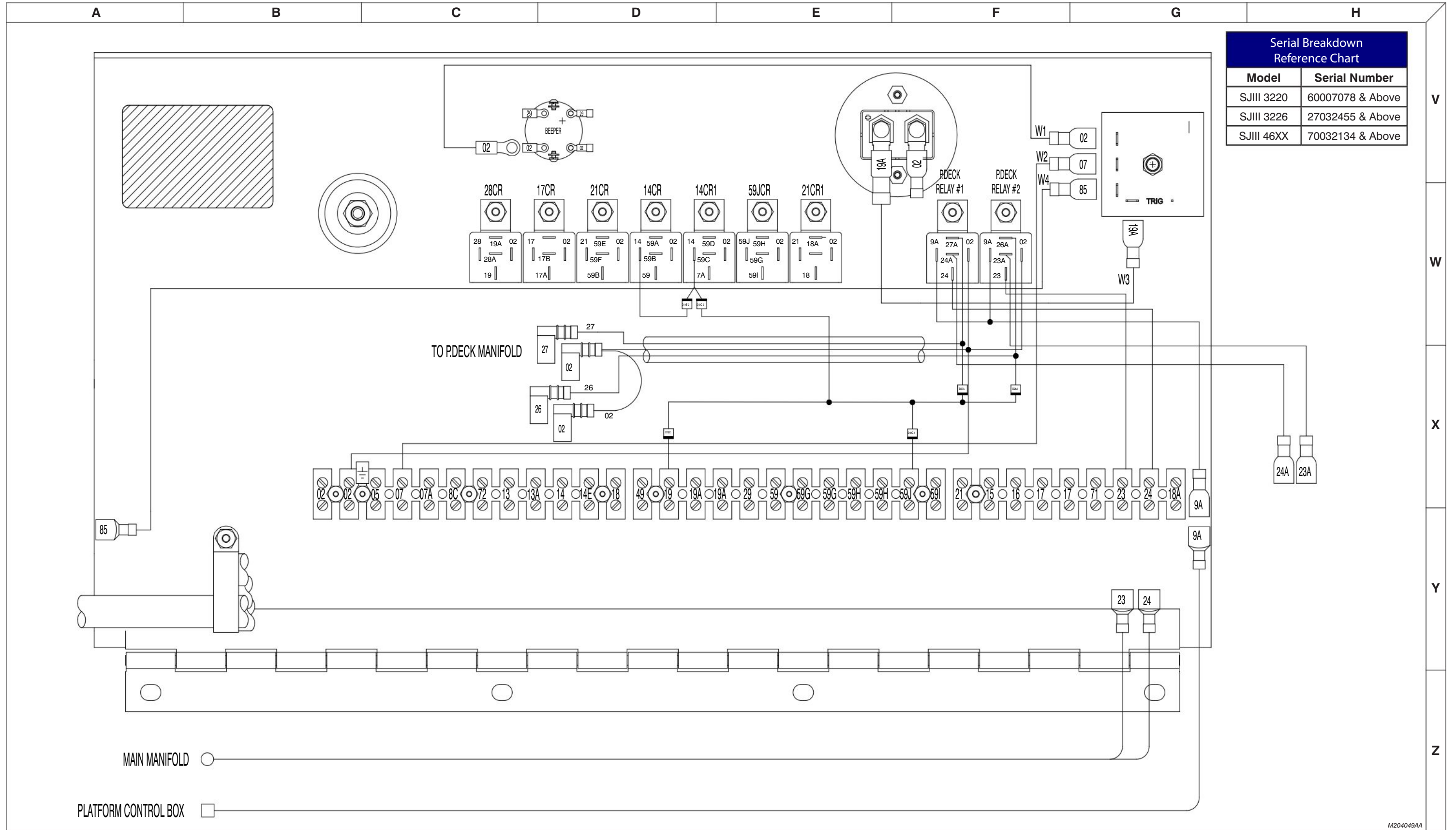

Serial Breakdown Reference Chart	
Model	Serial Number
SJIII 3220	60007078 & Above
SJIII 3226	27032455 & Above
SJIII 46XX	70032134 & Above

MAIN MANIFOLD ○

PLATFORM CONTROL BOX □

M204049AA

6.8 Main Manifold Harness - Motor Controller

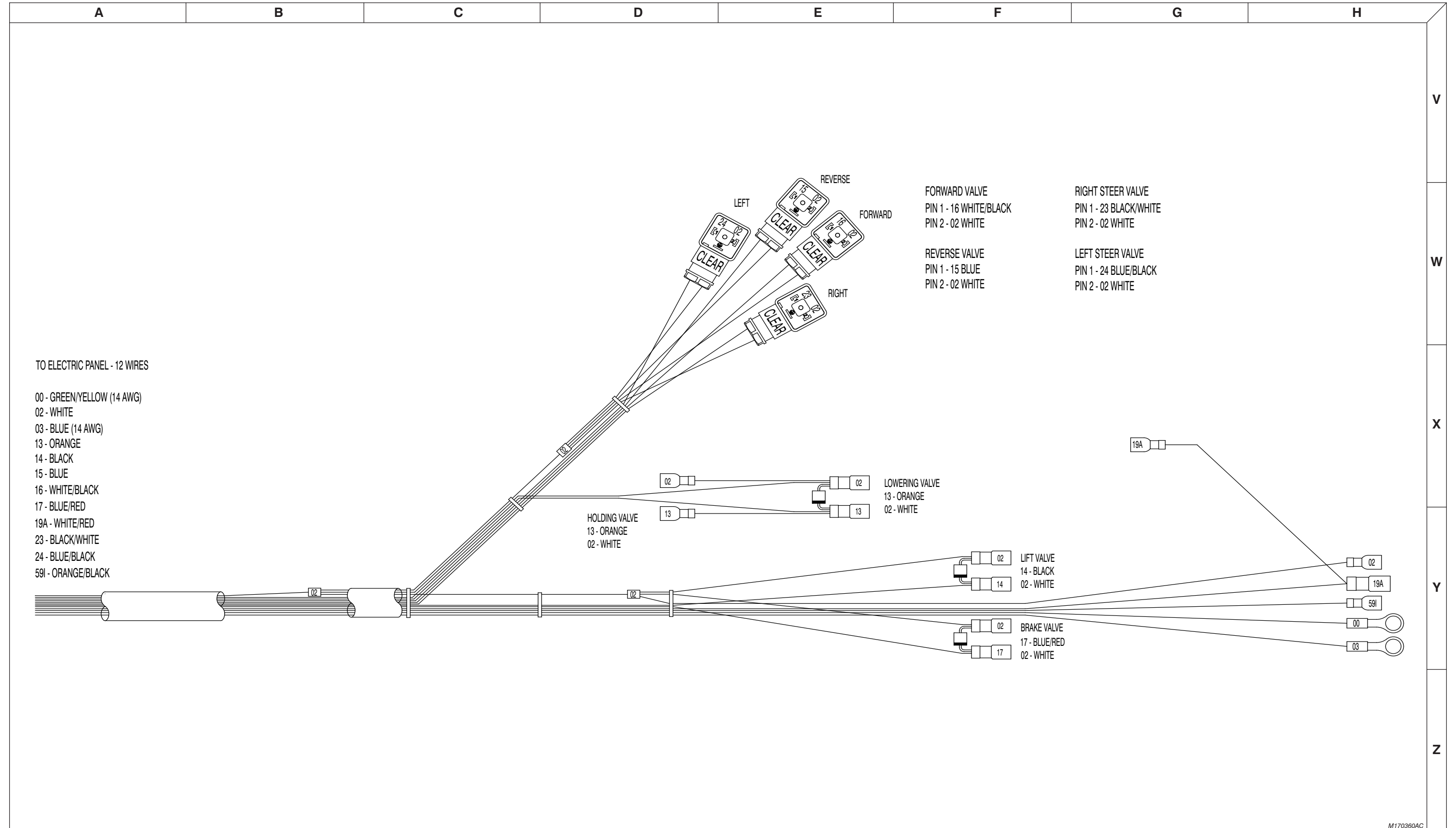

6.9 Hydraulic Schematic (Models 32XX) - Motor Controller

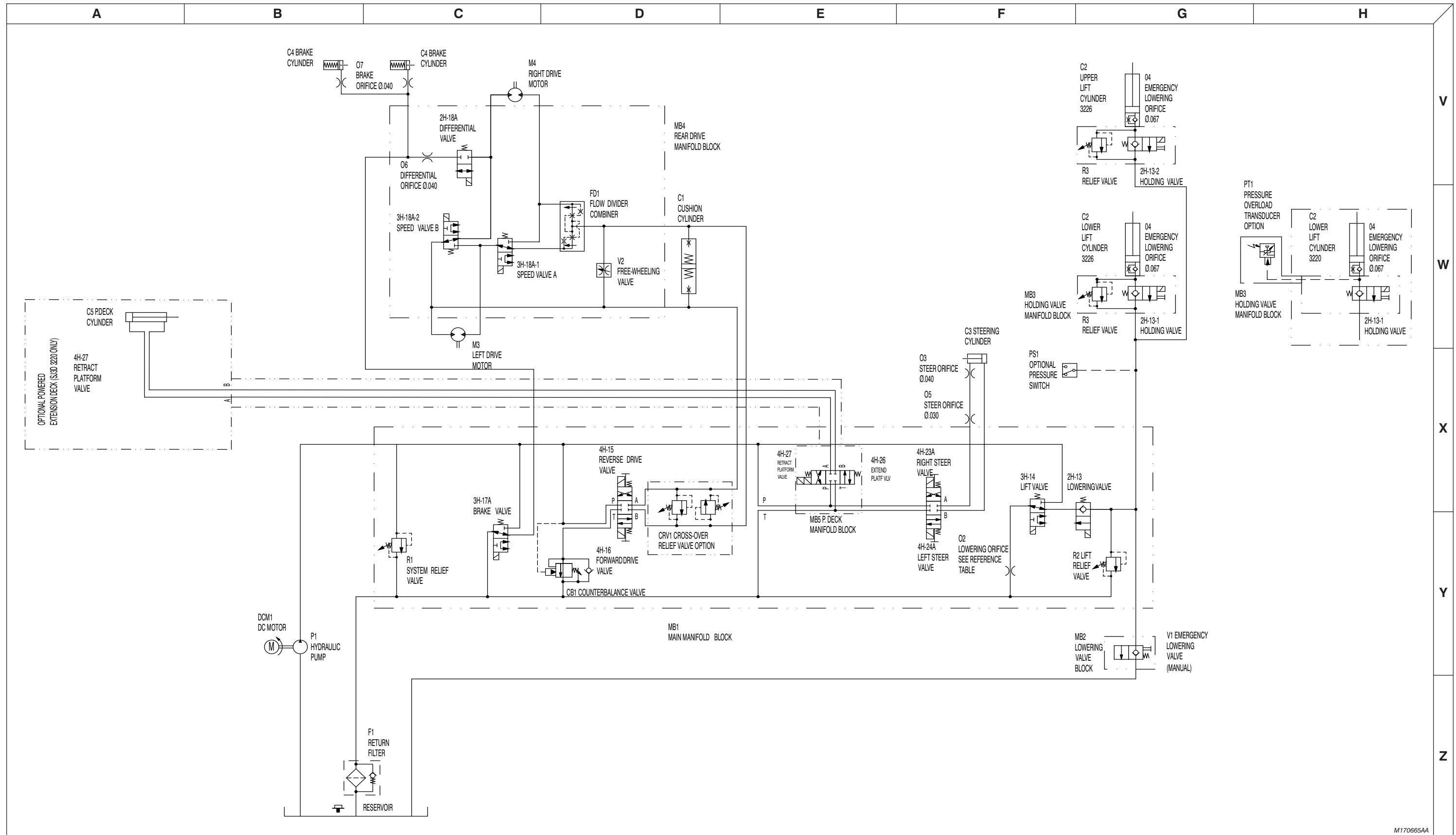

M170665AA

6.10b Hydraulic Schematic (Models 46XX) - Motor Controller

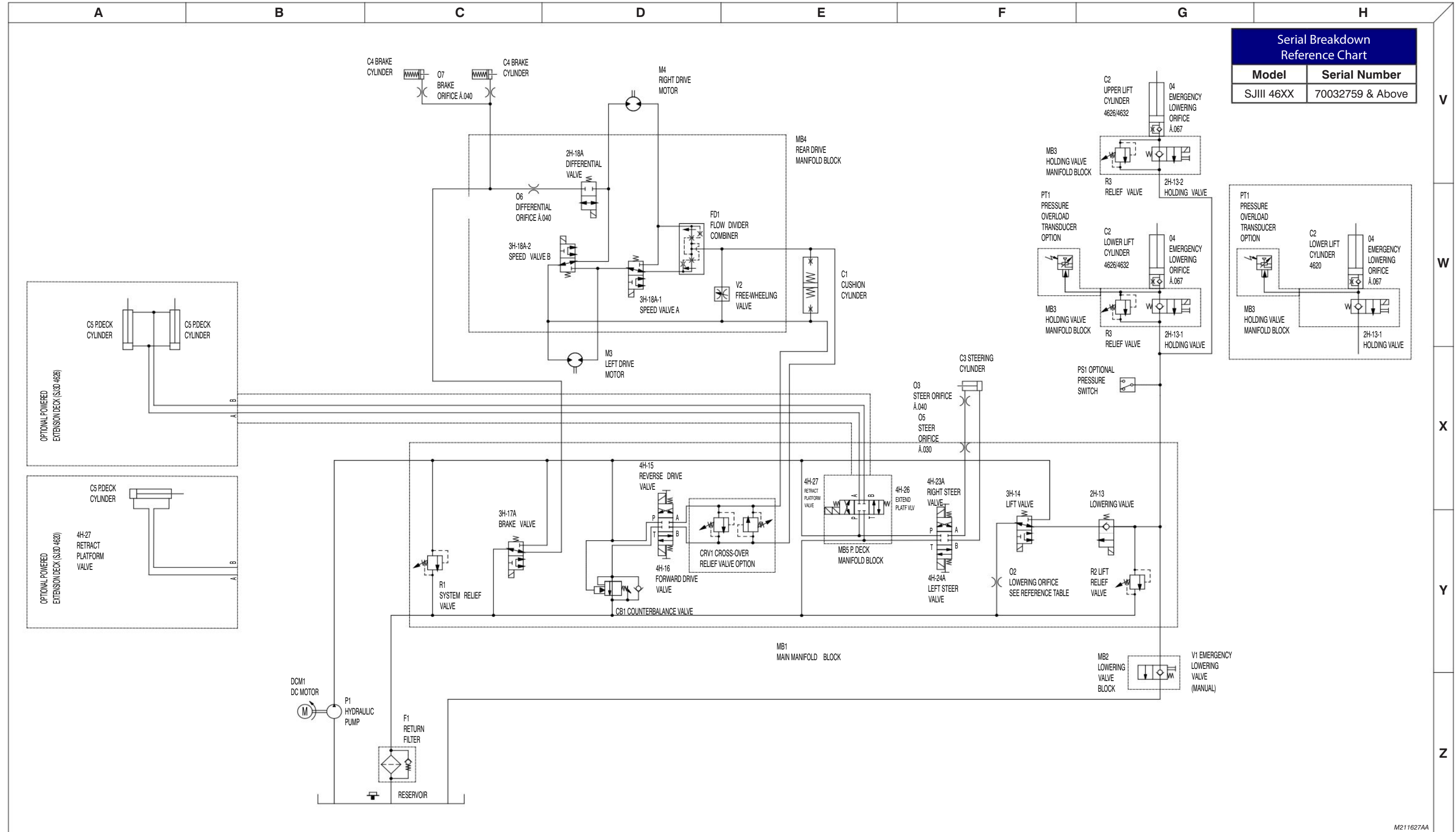

Serial Breakdown Reference Chart

Model	Serial Number
SJIII 46XX	70032759 & Above

M211627AA

Notes

A	B	C	D	E	F	G	H

V

W

X

Y

Z

6.11a Electrical Schematic - Motor Controller

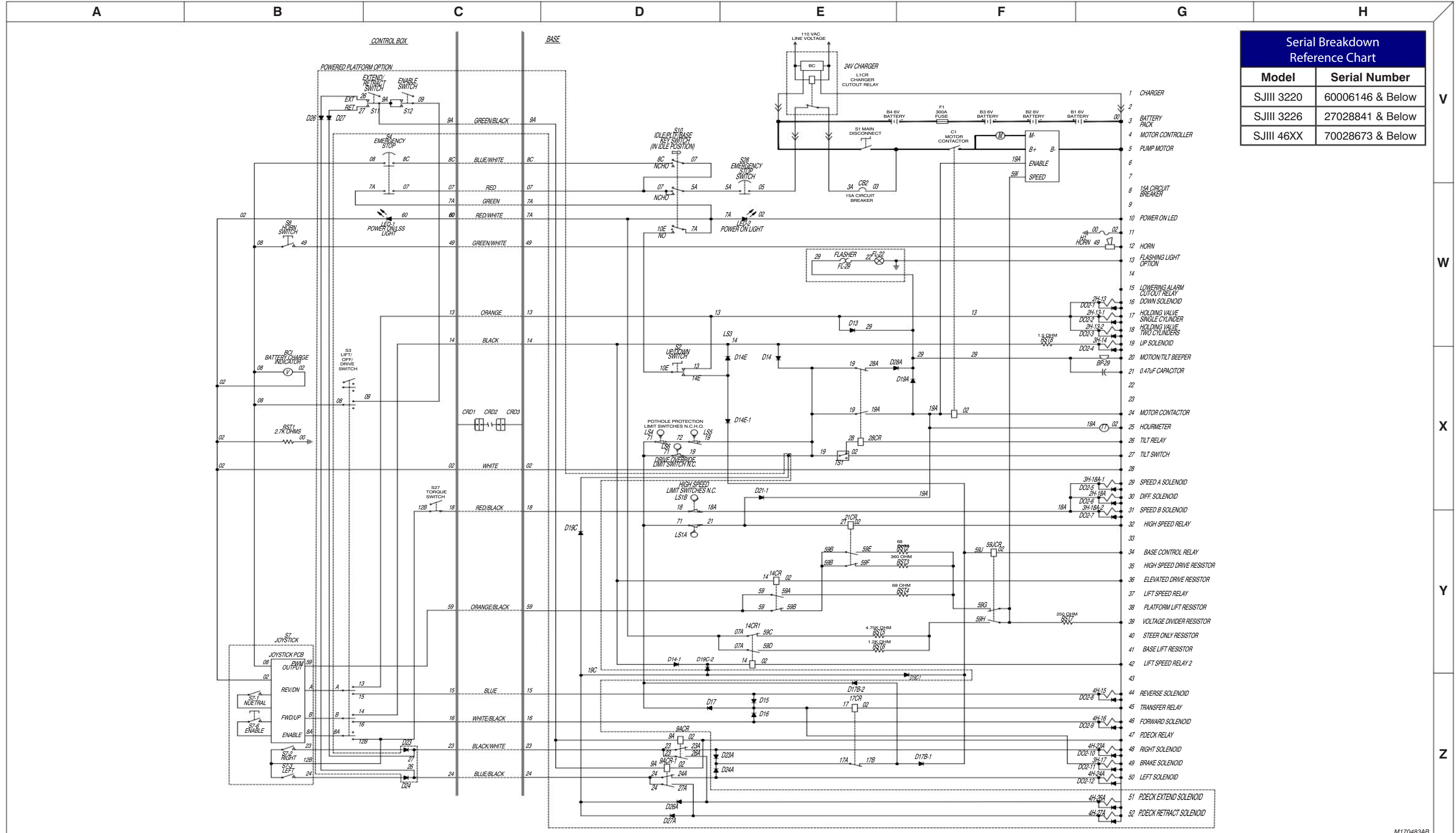

Serial Breakdown Reference Chart	
Model	Serial Number
SJIII 3220	60006146 & Below
SJIII 3226	27028841 & Below
SJIII 46XX	70028673 & Below

M170483AB

6.11b Electrical Schematic - Motor Controller

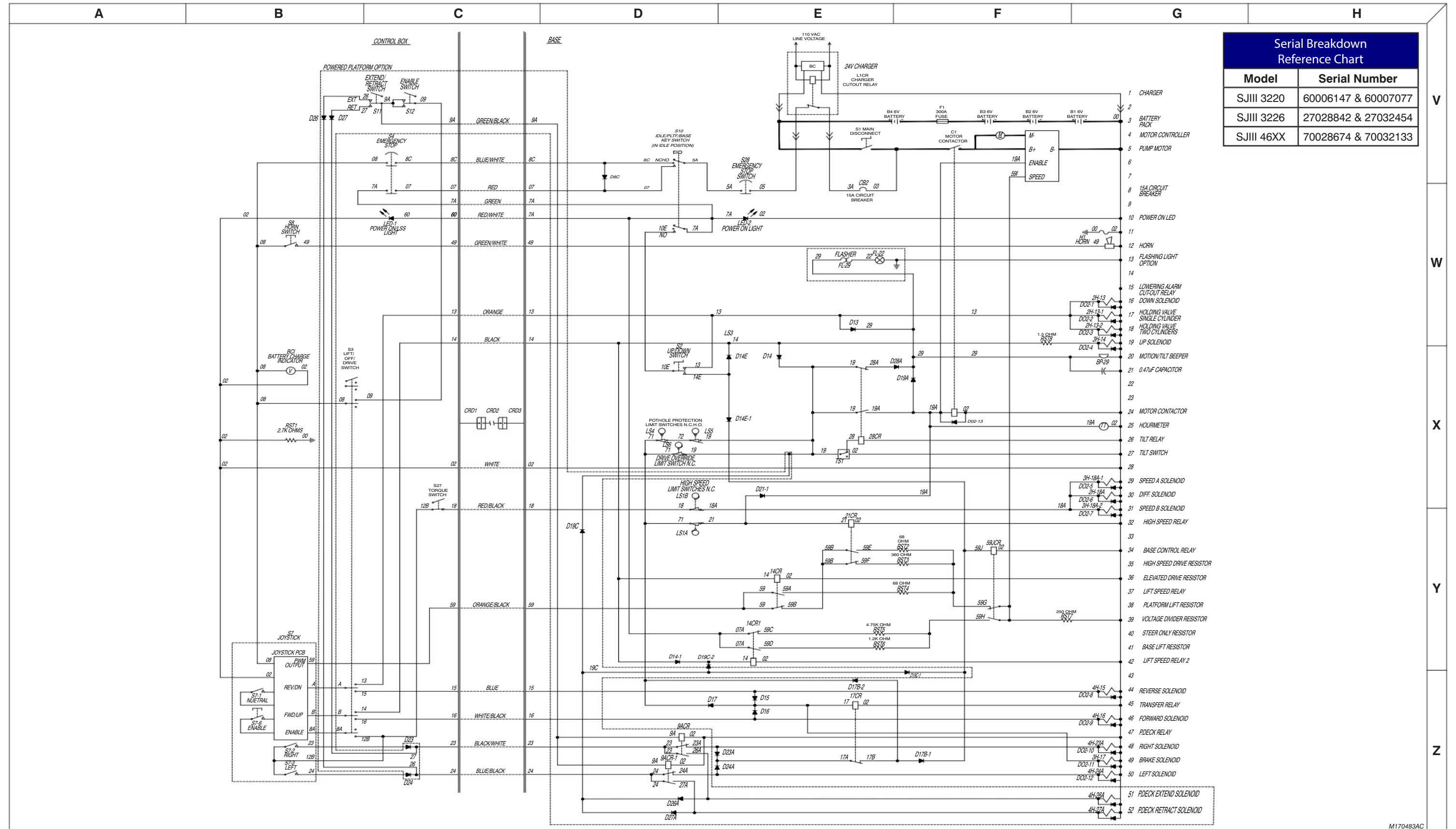

Serial Breakdown Reference Chart	
Model	Serial Number
SJIII 3220	60006147 & 60007077
SJIII 3226	27028842 & 27032454
SJIII 46XX	70028674 & 70032133

6.11c Electrical Schematic - Motor Controller

AK

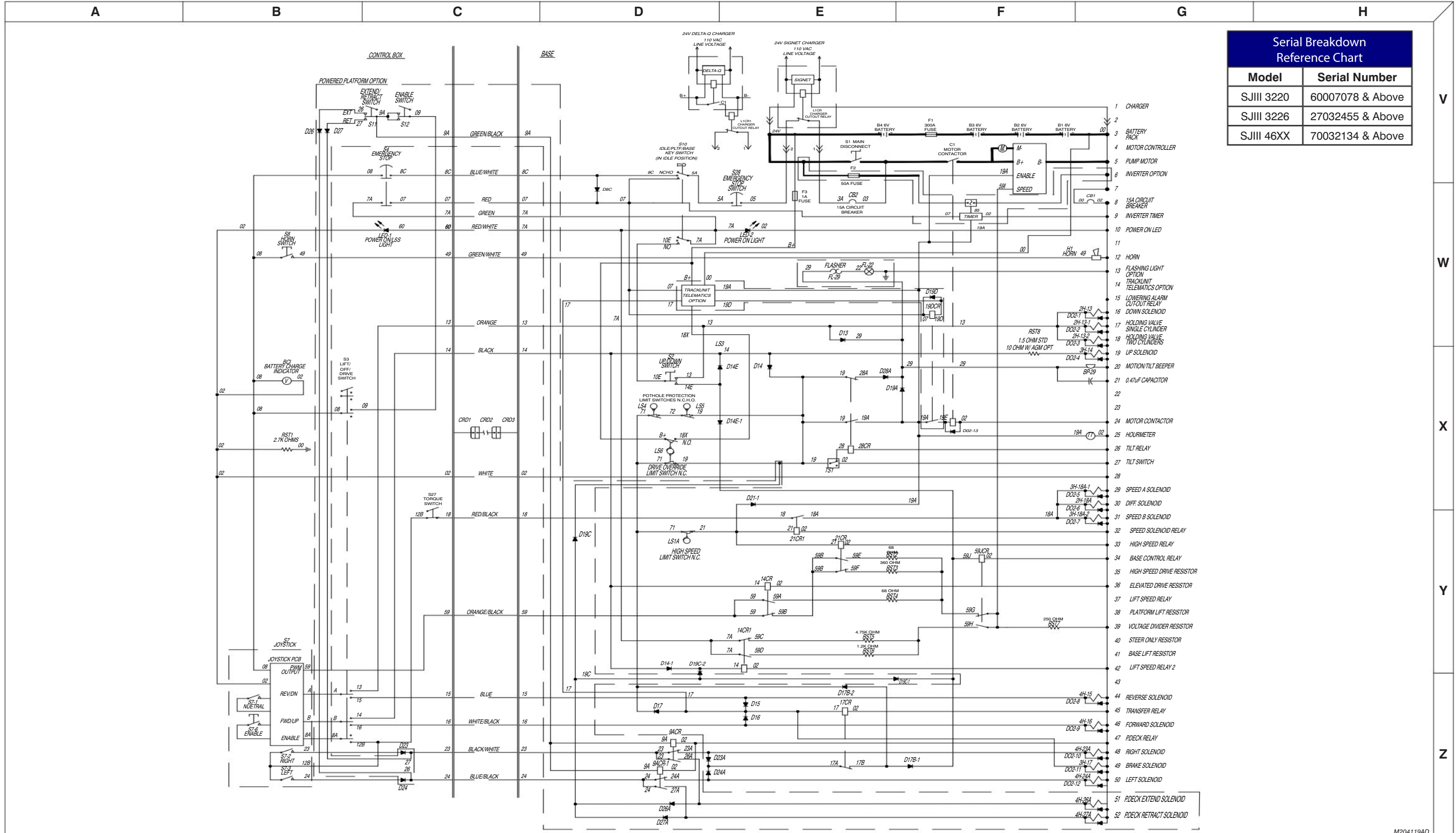

Serial Breakdown Reference Chart	
Model	Serial Number
SJIII 3220	60007078 & Above
SJIII 3226	27032455 & Above
SJIII 46XX	70032134 & Above

V

W

X

Y

Z

Introduction - Troubleshooting

The following pages contain a table of Troubleshooting Information for locating and correcting most service trouble which can develop. Careful and accurate analysis of the systems listed in the table of Troubleshooting Information will localize the trouble more quickly than any other method. This manual cannot cover all possible troubles and deficiencies that may occur. If a specific trouble is not listed, isolate the major component in which the trouble occurs, isolate whether the problem is electrical or hydraulic, and then isolate and correct the specific problem.

The content of this section is separated into “probable cause” and “remedy.” The information preceded by a number represents the “probable cause.” The following line, noted by a dash represents the “remedy” to the “probable cause” directly above it. See example below for clarification.

1. Probable Cause
 - [Remedy](#)

Section 6

Electrical System**6.12-1 All Controls Inoperative**

1. Battery charger plugged into external power source.
 - Disconnect charger cord.
2. Batteries disconnected.
 - Connect batteries.
3. Dirty or loose battery terminals.
 - Clean and tighten connections.
4. Battery charge low.
 - Check each cell with a hydrometer. Reading should be 1.275 (fully charged). Recharge if low reading. Replace if reading difference between cells is 0.050.
5. Main battery cables open or defective.
 - Check continuity. Replace if defective.
6. Fuse F1 defective.
 - Replace fuse.
7. Main battery disconnect switch S1 open or defective.
 - Close switch. Check continuity. Replace if defective.
8. Loose or broken wire #3 from motor contactor C1 to circuit breaker CB2.
 - Check continuity. Replace if defective.
9. Defective or tripped circuit breaker CB2.
 - Reset circuit breaker. Replace if defective.
10. Loose or broken wire #3A from circuit breaker CB2 to charger relay L1CR.
 - Check continuity. Replace if defective.
11. Defective battery charger relay L1CR.
 - Check relay. Replace if defective.
12. Loose or broken wire #5 from charger relay L1CR to base emergency stop switch S28.
 - Check continuity. Replace if defective.
13. Open or defective base emergency stop switch S28.
 - Close switch. Check switch. Replace if defective.
14. Loose or broken wire #5A from base emergency stop switch S28 to base key switch S10.
 - Check continuity. Replace if defective.
15. Open or defective base key switch S10.
 - Select function with switch. Check switch. Replace if defective.
16. Loose or broken wire #07 from base key switch S10 to base terminal block.
 - Check continuity. Replace if defective.
17. Loose or broken wire #07 from base terminal block to platform emergency stop switch S4.
 - Check continuity. Replace if defective.
18. Open or defective platform emergency stop switch S4.
 - Close switch. Replace if defective.
19. Loose or broken wire #7A from platform emergency stop switch S4 to base terminal block.
 - Check continuity. Replace if defective.
20. Loose or broken wire #7A from base terminal block to base key switch S10.
 - Check continuity. Replace if defective.
21. Open or defective base key switch S10.
 - Close switch. Replace if defective.
22. Loose or broken wire #00 from motor controller to circuit breaker CB1.
 - Check continuity. Replace if defective.
23. Defective or tripped circuit breaker CB1.
 - Reset circuit breaker. Replace if defective.
24. Loose or broken wire #02 from circuit breaker CB1 to base terminal block.
 - Check continuity. Replace if defective.

Electrical System (Continued)

6.12-2 All Controls Except for Down Function Inoperative

1. Loose or broken wire #59I from base terminal block to motor controller.
 - Check continuity. Replace if defective.
2. Loose or broken wire #19 or #02 from base terminal block to tilt switch TS1.
 - Check continuity. Replace if defective.
3. Loose or broken wire #28 from tilt switch to tilt relay 28CR.
 - Check continuity. Replace if defective.
4. Defective tilt relay 28CR.
 - Check relay. Replace if defective.
5. Loose or broken wire #19A from tilt relay 28CR to base terminal block.
 - Check continuity. Replace if defective.
6. Loose or broken wire #19A from base terminal block to motor controller.
 - Check continuity. Replace if defective.
7. Defective resistor RST7. (With joystick fully stroked)
 - Check resistor and make sure it is secure. Replace if defective.
8. Loose or broken B- cable from batteries to B- lug on motor controller.
 - Check continuity. Replace if defective.
9. Loose or broken B+ cable from main battery disconnect switch S1 to motor contactor C1.
 - Check continuity. Replace if defective.
10. Loose or broken B+ cable from motor contactor C1 to motor DCM1.
 - Check continuity. Replace if defective.
11. Loose or broken B+ cable from motor DCM1 to B+ lug on motor controller.
 - Check continuity. Replace if defective.
12. Loose or broken B- cable from motor DCM1 to M- lug on motor controller.
 - Check continuity. Replace if defective.
13. Defective motor controller.
 - Check motor controller input and output voltage. Replace if defective.
14. Defective motor DCM1.
 - Check motor for operation with 24 volt supply. Replace if defective.

6.12-3 All Controls Inoperative From Base Control Console

1. Loose or broken wire #10E from base key switch S10 to base up/down switch S2.
 - Check continuity. Replace if defective.

6.12-4 No Up Function from Base Control Console

1. Defective up/down switch S2.
 - Check switch. Replace if defective.
2. Loose or broken wire #14E from up/down switch S2 to base terminal block.
 - Check continuity. Replace if defective.
3. Open or defective diode D14E-1.
 - Check diode. Replace if defective.
4. Open or defective diode D14E-2.
 - Check diode. Replace if defective.
5. Open diode D14.
 - Check diode. Replace if defective.
6. Loose or broken wire #14A from base terminal block to relay 14ACR.
 - Check continuity. Replace if defective.
7. Loose or broken wire #14 from relay 14CR to relay 14CR1.
 - Check continuity. Replace if defective.
8. Defective low voltage protection resistor RST8.
 - Check resistor and make sure it is secure. Replace if defective.

Section 6

Electrical System (Continued)

9. Loose or broken wire #14A from base terminal block to up valve coil 3H-14A.
 - Check continuity. Replace if defective
10. Loose or broken wire #02 from base terminal block to up valve coil 3H-14A.
 - Check continuity. Replace if defective.
11. Defective up valve coil 3H-14A.
 - Check continuity through coil. Replace if defective.
12. Machine not level. (Above high speed limit switch)
 - Use on level surface.
13. Loose or broken wire #59J from base terminal block to base control relay 59JCR.
 - Check continuity. Replace if defective.
14. Loose or broken wire #02 from base terminal block to base control relay 59JCR.
 - Check continuity. Replace if defective.
15. Defective base control relay 59JCR.
 - Check relay. Replace if defective.
16. Loose or broken wire #7A from base terminal block to lift speed relay 14CR1.
 - Check continuity. Replace if defective.
17. Loose or broken wire #59D from lift speed relay 14CR1 to base terminal block.
 - Check continuity. Replace if defective.
18. Defective base lift resistor RST6.
 - Check resistor and make sure it is secure. Replace if defective.
19. Loose or broken jumper wire #59H at base terminal block.
 - Check continuity. Replace if defective.
20. Loose or broken wire #59H from base terminal block to base control relay 59JCR.
 - Check continuity. Replace if defective.

6.12-5 Up Function Slow from Base Control Console

1. Loose or broken wire #14 from base terminal block to lift speed relay 14CR1.
 - Check continuity. Replace if defective.
2. Loose or broken wire #02 from base terminal block to lift speed relay 14CR1.
 - Check continuity. Replace if defective.
3. Defective lift speed relay 14CR1.
 - Check relay. Replace if defective.

6.12-6 No Down Function from Base Control Console

NOTE

Down function is not proportionally controlled.

1. Defective up/down switch S2.
 - Check switch. Replace if defective.
2. Loose or broken wire #13 from up/down switch S2 to base terminal block.
 - Check continuity. Replace if defective.
3. Loose or broken wire # 13 from base terminal block to down valve 2H-13 or holding valve 2H-13-1 and 2H-13-2 (if equipped).
 - Check continuity. Replace if defective.
4. Defective down valve coil 2H-13.
 - Check continuity through coil. Replace if defective.
5. Defective lift cylinder holding valve coil 2H-13-1 or 2H-13-2 (if equipped).
 - Check continuity through coil. Replace if defective.
6. Loose or broken wire #02 from holding valve coil 2H-13-1 or 2H-13-2 (if equipped) or down valve coil 2H-13 to base terminal block.
 - Check continuity. Replace if defective.

Electrical System (Continued)

6.12-7 All Controls Inoperative From Platform Control Console

1. Loose or broken wire #8C from base key switch S10 to base terminal block.
 - Check continuity. Replace if defective.
2. Loose or broken wire #8C or wire #02 from base terminal block to platform emergency stop switch S4.
 - Check continuity. Replace if defective.
3. Open or defective platform emergency stop switch S4.
 - Close switch. Replace if defective.
4. Loose or broken wire #8 or wire #02 from emergency stop switch S4 to battery charge indicator BCI.
 - Check continuity. Replace if defective.
5. Loose or broken wire #8 or wire #02 from battery charge indicator BC1 to joystick S7.
 - Check continuity. Replace if defective.
6. Defective joystick enable switch S7-6.
 - Check switch. Replace if defective.
7. Defective joystick neutral switch S7-1.
 - Check switch. Replace if defective.
8. Defective joystick S7.
 - Check joystick. Replace if defective.

6.12-8 No Up Function from Platform Controls

1. Loose or broken wire "B" from proportional controller S7 to lift/drive switch S3.
 - Check continuity. Replace if defective.
2. Lift/Drive switch S3 defective.
 - Check switch. Replace if defective.
3. Defective PWM card on joystick S7.
 - Check joystick card. Replace if defective.
4. Loose or broken wire #14 from lift/drive switch S3 to base terminal block.
 - Check continuity. Replace if defective.
5. Open or defective diode D14.
 - Check diode. Replace if defective.
6. Loose or broken wire #14 or #02 from base terminal block to relay 14CR.
 - Check continuity. Replace if defective.
7. Loose or broken wire #59 from proportional controller S7 to base terminal block.
 - Check continuity. Replace if defective.
8. Loose or broken wire #59 from base terminal block to relay 14CR.
 - Check continuity. Replace if defective.
9. Defective lift speed relay 14CR.
 - Check relay. Replace if defective.
10. Defective low voltage protection resistor RST8.
 - Check resistor and make sure it is secure. Replace if defective.
11. Loose or broken wire #14A or #02 from base terminal block to up valve coil 3H-14A.
 - Check continuity. Replace if defective.
12. Defective up valve coil 3H-14A.
 - Check continuity through coil. Replace if defective.
13. Machine not level. (Above high speed limit switch)
 - Use on level surface.
14. Loose or broken wire #59A from lift speed relay 14CR to base terminal block.
 - Check continuity. Replace if defective.
15. Defective base lift resistor RST4.
 - Check resistor and make sure it is secure. Replace if defective.

Electrical System (Continued)

16. Loose or broken wire #59G from base terminal block to base control relay 59JCR.
 - Check continuity. Replace if defective.
17. Defective base control relay 59JCR.
 - Check relay. Replace if defective.

6.12-9 Up Function Slow from Platform Control Console

1. Loose or broken wire #14 from base terminal block to lift speed relay 14CR.
 - Check continuity. Replace if defective.
2. Loose or broken wire #02 from base terminal block to lift speed relay 14CR.
 - Check continuity. Replace if defective.
3. Defective lift speed relay 14CR.
 - Check relay. Replace if defective.

6.12-10 No Down Function from Platform Controls

1. Loose or broken wire "A" from proportional controller S7 to lift/drive switch S3.
 - Check continuity. Replace if defective.
2. Lift/Drive switch S3 defective.
 - Check switch. Replace if defective.
3. Loose or broken wire #13 from lift/drive switch S3 to base terminal block.
 - Check continuity. Replace if defective.
4. Loose or broken wire # 13 from base terminal block to down valve 2H-13 or holding valve 2H-13-1 and 2H-13-2 (if equipped).
 - Check continuity. Replace if defective.
5. Defective down valve coil 2H-13.
 - Check continuity through coil. Replace if defective.
6. Defective lift cylinder holding valve coil 2H-13-1 or 2H-13-2 (if equipped).
 - Check continuity through coil. Replace if defective.
7. Loose or broken wire #02 from holding valve coil 2H-13-1 or 2H-13-2 (if equipped) or down valve coil 2H-13 to base terminal block.
 - Check continuity. Replace if defective.

6.12-11 Steer Only Inoperative

1. Loose or broken wire #8A from proportional controller S7 to lift/off/drive switch S3.
 - Check continuity. Replace if defective.
2. Lift/Off/Drive switch S3 defective.
 - Check switch. Replace if defective.
3. Loose or broken wire #12B from steer switches S7-2 and S7-3 to lift/off/drive switch S3.
 - Check continuity. Replace if defective.
4. Loose or broken wire #17A from base terminal block to relay 17CR.
 - Check continuity. Replace if defective.
5. Defective relay 17CR.
 - Check relay. Replace if defective.
6. Loose or broken wire #17B from relay 17CR to base terminal block.
 - Check continuity. Replace if defective.
7. Open diode D17B-1.
 - Check diode. Replace if defective.
8. Open diode D17B-2.
 - Check diode. Replace if defective.
9. Defective lift speed relay 14CR1.
 - Check relay. Replace if defective.

Electrical System (Continued)

10. Loose or broken wire #59C from 14CR1 lift speed relay to base terminal block.
 - Check continuity. Replace if defective.
11. Defective steer only resistor RST5.
 - Check resistor and make sure it is secure. Replace if defective.

6.12-12 Right Steer Inoperative (Without power deck option)

1. Defective right steer switch S7-2.
 - Check switch. Replace if defective.
2. Loose or broken wire #23 from right steer switch S7-2 to base terminal block.
 - Check continuity. Replace if defective.
3. Loose or broken wire #23 from base terminal block to steer right valve coil 4H-23.
 - Check continuity. Replace if defective.
4. Defective steer right valve coil 4H-23.
 - Check continuity through coil. Replace if defective.
5. Loose or broken wire #02 from steer right valve coil 4H-23 to base terminal block.
 - Check continuity. Replace if defective.
6. Open diode D23.
 - Check diode. Replace if defective.

6.12-13 Right Steer Inoperative (With power deck option)

1. Defective right steer switch S7-2.
 - Check switch. Replace if defective.
2. Loose or broken wire #23 from right steer switch S7-2 to base terminal block.
 - Check continuity. Replace if defective.
3. Loose or broken wire #23 from base terminal block to power deck relay 9ACR.
 - Check continuity. Replace if defective.
4. Defective relay 9ACR.
 - Check relay. Replace if defective.
5. Loose or broken wire #23A from power deck relay 9ACR to steer right valve coil 4H-23A.
 - Check continuity. Replace if defective.
6. Defective steer right valve coil 4H-23A.
 - Check continuity through coil. Replace if defective.
7. Loose or broken wire #02 from steer right valve coil 4H-23A to base terminal block.
 - Check continuity. Replace if defective.
8. Open diode D23A.
 - Check diode. Replace if defective.

6.12-14 Left Steer Inoperative (Without power deck option)

1. Defective left steer switch S7-3.
 - Check switch. Replace if defective.
2. Loose or broken wire #24 from left steer switch S7-3 to base terminal block.
 - Check continuity. Replace if defective.
3. Loose or broken wire #24 from base terminal block to steer left valve coil 4H-24.
 - Check continuity. Replace if defective.
4. Defective steer left valve coil 4H-24.
 - Check continuity through coil. Replace if defective.
5. Loose or broken wire #02 from steer left valve coil 4H-24 to base terminal block.
 - Check continuity. Replace if defective.
6. Open diode D24.
 - Check diode. Replace if defective.

Electrical System

6.12-15 Left Steer Inoperative (With power deck option)

1. Defective left steer switch S7-3.
 - Check switch. Replace if defective.
2. Loose or broken wire #24 from left steer switch S7-3 to base terminal block.
 - Check continuity. Replace if defective.
3. Loose or broken wire #24 from base terminal block to power deck relay 9ACR-1.
 - Check continuity. Replace if defective.
4. Defective relay 9ACR-1.
 - Check relay. Replace if defective.
5. Loose or broken wire #24A from power deck relay 9ACR-1 to steer left valve coil 4H-24A.
 - Check continuity. Replace if defective.
6. Defective steer left valve coil 4H-24A.
 - Check continuity through coil. Replace if defective.
7. Loose or broken wire #02 from steer left valve coil 4H-24A to base terminal block.
 - Check continuity. Replace if defective.
8. Open diode D24A.
 - Check diode. Replace if defective.

6.12-16 Drive Only Inoperative

1. Open or defective diode D17.
 - Check diode. Replace if defective.
2. Loose or broken wire #59B from lift speed relay 14CR to base terminal block.
 - Check continuity. Replace if defective.
3. Defective relay 14CR.
 - Check relay. Replace if defective.
4. Loose or broken wire #59B from base terminal block to high speed relay 21CR.
 - Check continuity. Replace if defective.

6.12-17 No Drive or Steer when Platform Fully Lowered

1. Loose or broken wire #71 from base terminal block to drive override limit switch LS6.
 - Check continuity. Replace if defective.
2. Defective drive override switch LS6.
 - Check switch. Replace if defective.
3. Loose or broken wire #19 from drive override limit switch LS6 to base terminal block.
 - Check continuity. Replace if defective.

6.12-18 No Drive or Steer when Platform Elevated

1. Pothole protection bars not fully lowered.
 - Clear obstructions. Repair as needed.
2. Loose or broken wire #71 from base terminal block to pothole protection limit switch LS4.
 - Check continuity. Replace if defective.
3. Defective pothole protection limit switch LS4.
 - Check switch. Replace if defective.
4. Loose or broken wire #72 from pothole protection limit switch LS4 to base terminal block.
 - Check continuity. Replace if defective.
5. Loose or broken wire #72 from base terminal block to pothole protection limit switch LS5.
 - Check continuity. Replace if defective.
6. Defective pothole protection limit switch LS5.
 - Check switch. Replace if defective.
7. Loose or broken wire #19 from pothole protection limit switch LS5 to base terminal block.
 - Check continuity. Replace if defective.

Electrical System

6.12-19 Platform Drives in Slow Speed Only

1. Loose or broken wire #71 from base terminal block to high speed limit switch LS1A.
 - Check continuity. Replace if defective.
2. Open or defective high speed limit switch LS1A.
 - Check switch. Replace if defective.
3. Loose or broken wire #21 from high speed limit switch LS1A to base terminal block.
 - Check continuity. Replace if defective.
4. Loose or broken wire #59E from high speed relay 21CR to base terminal block.
 - Check continuity. Replace if defective.
5. High speed relay 21CR defective.
 - Check relay, replace if defective.
6. Defective high speed resistor RST2.
 - Check resistor and make sure it is secure. Replace if defective.

6.12-20 High/Low Torque Inoperative

1. Loose or broken wire #12B from joystick card to torque switch S27.
 - Check continuity. Replace if defective.
2. Defective torque switch S27.
 - Check switch. Replace if defective.
3. Loose or broken wire #18 from torque switch S27 to base terminal block.
 - Check continuity. Replace if defective.
4. Loose or broken wire #18 from base terminal block to high speed limit switch LS1B.
 - Check continuity. Replace if defective.
5. Defective high speed limit switch LS1B.
 - Check switch. Replace if defective.
6. Loose or broken wire #18A from high speed limit switch LS1B to rear drive manifold.
 - Check continuity. Replace if defective.
7. Defective speed valve coil 3H-18A-1 or 3H-18A-2.
 - Check continuity through coil. Replace if defective.
8. Loose or broken wire #02 from rear drive manifold to base terminal block.
 - Check continuity. Replace if defective.

6.12-21 Brake will not Release

1. Diode D16 forward or D15 reverse is shorted or open.
 - Check diode. Replace if defective.
2. Loose or broken wire #17 from base terminal block to brake valve coil 3H-17.
 - Check continuity. Replace if defective.
3. Brake valve coil 3H-17 defective.
 - Check continuity through coil. Replace if defective.
4. Loose or broken wire #02 from brake valve coil 3H-17 to base terminal block.
 - Check continuity. Replace if defective.

6.12-22 Forward Drive Function Inoperative

1. Loose or broken wire #16 from lift/drive switch S3 to base terminal block.
 - Check continuity. Replace if defective.
2. Loose or broken wire #16 from base terminal block to forward drive valve coil 4H-16.
 - Check continuity. Replace if defective.
3. Forward drive valve coil 4H-16 defective.
 - Check continuity through coil. Replace if defective.
4. Loose or broken wire #02 from forward drive valve coil 4H-16 to base terminal block.
 - Check continuity. Replace if defective.

Section 6

Electrical System

6.12-23 Reverse Drive Function Inoperative

1. Loose or broken wire #15 from lift/drive switch S3 to base terminal block.
 - Check continuity. Replace if defective.
2. Loose or broken wire #15 from base terminal block to reverse drive valve coil 4H-15.
 - Check continuity. Replace if defective.
3. Reverse drive valve coil 4H-15 defective.
 - Check continuity through coil. Replace if defective.
4. Loose or broken wire #02 from reverse drive valve coil 4H-15 to base terminal block.
 - Check continuity. Replace if defective.

6.12-24 Power Extension Platform will not Extend or Retract

1. Lift/Drive switch S3 not in lift position.
 - Move switch to lift position.
2. Loose or broken wire #09 from lift/drive switch S3 to power extension platform enable switch S12.
 - Check continuity. Replace if defective.
3. Power extension platform enable switch S12 defective.
 - Check switch. Replace if defective.
4. Loose or broken wire #09A from power extension platform enable switch S12 to platform extend/retract switch S11.
 - Check continuity. Replace if defective.
5. Loose or broken wire #9A from platform control box to base terminal block.
 - Check continuity. Replace if defective.
6. Loose or broken wire #9A from base terminal block to 9ACR extend relay or 9ACR-1 retract relay.
 - Check continuity. Replace if defective.
7. Defective relay 9ACR or 9ACR-1.
 - Check relay, replace if defective.

6.12-25 Power Extension Platform will not Extend

1. Powered extension platform extend/retract switch S11 defective.
 - Check switch. Replace if defective.
2. Open diode D26.
 - Check diode. Replace if defective.
3. Loose or broken wire #26 from diode D26 to wire #23.
 - Check continuity. Replace if defective.
4. Loose or broken wire #23 from right steer switch S7-2 to base terminal block.
 - Check continuity. Replace if defective.
5. Loose or broken wire #23 from base terminal block to power deck relay 9ACR.
 - Check continuity. Replace if defective.
6. Defective relay 9ACR.
 - Check relay. Replace if defective.
7. Loose or broken wire #26A from power deck relay 9ACR to extend valve coil 4H-26A.
 - Check continuity. Replace if defective.
8. Defective extend valve coil 4H-26A.
 - Check continuity through coil. Replace if defective.
9. Loose or broken wire #02 from extend valve coil 4H-26A to base terminal block.
 - Check continuity. Replace if defective.
10. Open diode D26A.
 - Check diode. Replace if defective.
11. Loose or broken wire #19C from diode D26A to base terminal block.
 - Check continuity. Replace if defective.
12. Open diode D19C or D19C-1 or D19C-2.
 - Check diode. Replace if defective.

Electrical System (Continued)

6.12-26 Power Extension Platform will not Retract

1. Powered extension platform extend/retract switch S11 defective.
 - Check switch. Replace if defective.
2. Open diode D27.
 - Check diode. Replace if defective.
3. Loose or broken wire #27 from diode D27 to wire #24.
 - Check continuity. Replace if defective.
4. Loose or broken wire #24 from left steer switch S7-3 to base terminal block.
 - Check continuity. Replace if defective.
5. Loose or broken wire #24 from base terminal block to power deck relay 9ACR-1.
 - Check continuity. Replace if defective.
6. Defective relay 9ACR-1.
 - Check relay. Replace if defective.
7. Loose or broken wire #27A from power deck relay 9ACR-1 to retract valve coil 4H-27A.
 - Check continuity. Replace if defective.
8. Defective retract valve coil 4H-27A.
 - Check continuity through coil. Replace if defective.
9. Loose or broken wire #02 from extend valve coil 4H-27A to base terminal block.
 - Check continuity. Replace if defective.
10. Open diode D27A.
 - Check diode. Replace if defective.
11. Loose or broken wire #19C from diode D27A to base terminal block.
 - Check continuity. Replace if defective.
12. Open diode D19C or D19C-1 or D19C-2.
 - Check diode. Replace if defective.

Hydraulic System

6.13-1 All Function Inoperative

1. Pump P1 defective.
 - Check pump. Replace if defective.

6.13-2 All System sluggish

1. System Relief Valve defective or not adjusted properly.
 - Adjust valve. Replace if defective.
2. Hydraulic pump P1 worn.
 - Check pump. Replace if defective.

6.13-3 Platform Drifts Down

1. Defective lift cylinder seals at the gland or holding valve manifold.
 - Replace if damaged. Note: There are no piston seals, just wear rings.
2. Combination of defective holding valves 2H-13C-1 and 2H-13-2, and either defective lowering valve 2H-13 or relief valve R2 or manual lowering valve V1.
 - Check valves. Replace if defective.

6.13-4 Platform Lifts Slowly

1. Open or leaking manual lowering valve V1.
 - Close valve. Replace if defective.
2. Lift relief valve R2 defective.
 - Check valve. Replace if defective.
3. Open manual override on holding valve 2H-13-1 or 2H-13-2.
 - Depress and turn manual override clockwise to close. Replace if defective.

Section 6**Hydraulic System (Continued)****6.13-5 Platform does not Lift**

1. Open manual lowering valve V1.
 - Close valve. Replace if defective.
2. Hydraulic oil level too low.
 - Fully lower the platform. Fill hydraulic tank until fluid is at or slightly above the top mark on the sight glass.
3. Platformweight excessive.
 - Reduce platform load to maximum capacity.
4. Up valve 3H-14A defective or is sticking.
 - Check valve. Replace if defective.

6.13-6 Platform will not Lower

NOTE

Down function is not proportionally controlled.

1. Lowering valve 2H-13 defective or is sticking.
 - Clean valve. Replace if defective.
2. Defective holding valve 2H-13-1 or 2H-13-2.
 - Clean valve. Replace if defective.

6.13-7 Platform Drives Slow

1. Free-wheeling valve V2 open or defective.
 - Close valve. Replace if defective.
2. Flow divider/combiner FD1 defective or is plugged.
 - Close valve. Replace if defective.
3. Drive motor M3 or M4 defective.
 - Check motors. Replace if defective.
4. Cushion cylinder C1 defective.
 - Check cylinder. Replace if defective.

6.13-8 Platform will not Drive in Forward or Reverse

1. Open free-wheeling valve V2.
 - Close Valve. Replace if defective.
2. Forward drive valve 4H-16 or reverse drive valve 4H-15 defective or is sticking.
 - Check Valve. Replace if defective.
3. Flow/Divider/Combiner valve FD1 defective or is plugged.
 - Check Valve. Replace if defective.
4. Counterbalance valve CB1 defective or is plugged.
 - Check Valve. Replace if defective.

6.13-9 Brake(s) will not Release (Pin brakes)

1. Brake valve 3H-17 defective or is sticking.
 - Clean valve. Replace if defective.
2. Brake orifice 04 plugged.
 - Remove orifice. Clean and reinstall.
3. Brake cylinders C4 defective.
 - Rebuild cylinder. Replace if damaged.

6.13-10 Brake(s) will not Release (Integral brakes)

1. Brake valve 3H-17 defective or is sticking.
 - Clean valve. Replace if defective.

Hydraulic System (Continued)

2. Brake orifice(s) 07 plugged.
 - Remove orifice(s). Clean and reinstall.
3. Defective internal brake piston seals.
 - Check brake pack will maintain pressure. If pressure is not maintained replace seals.
4. Damaged integral brake in wheel motor.
 - Inspect wheel motor assembly. Repair and replace as necessary.

6.13-11 Aerial Platform will not hold on a Grade (Integral brakes)

1. Worn or damaged brake discs.
 - Inspect brake discs for wear. Replace if worn or damaged.
2. Broken or damaged brake compression springs.
 - Check springs. Replace if defective.

6.13-12 Platform does not Steer

1. Right steer valve 4H-23 or left steer valve 4H-24 defective or sticking.
 - Clean valve. Replace if defective.
2. Steer cylinder C3 seals leaking.
 - Rebuild cylinder(s). Replace if damaged.
3. Mechanical binding in kingpins.
 - Check for binding. Repair as needed.
4. Orifices 03 or O5 plugged.
 - Clean orifices, and reinstall.

6.13-13 Power Extension Platform will not Extend or Retract

1. Platform extend valve 4H-26A or platform retract valve 4H-27A defective or is sticking.
 - Clean valve. Replace if defective.
2. Powered platform cylinder C5 seals defective.
 - Rebuild cylinder. Replace if damaged.
3. Mechanical binding in power extension platform mechanism.
 - Check for binding. Repair as needed.

6.13-14 High/Low Torque Inoperative

1. Stuck speed valve 3H-18A-1.
 - Clean valve. Replace if defective.
2. Stuck speed valve 3H-18A-2.
 - Clean valve. Replace if defective.

Section 6

General

The following information is provided to assist you in the use and application of servicing and maintenance procedures contained in this chapter.

Safety and Workmanship

Your safety, and that of others, is the first consideration when engaging in the maintenance of equipment. Always be conscious of weight. Never attempt to move heavy parts without the aid of a mechanical device. Do not allow heavy objects to rest in an unstable position. When raising a portion of the equipment, ensure that adequate support is provided.

Platform

6.14-1 OEM Controller Electronics Information

Flow Control

Single coil or solenoid for single direction. The coil has two connections; one is wired to the P.C. Board (A) terminal and the other is wired to (-), or the negative side of the supply voltage. Switches to control directional valves may be provided on the controller.

Adjustment Procedures

Adjustments are made by turning a trimpot adjustment screw. The trimpots are multi-turn, end to end-devices. It may be necessary to turn the adjustment screw several turns to observe a change in output.

Clockwise (CW) adjustment of the trimpot increases the output.

Counter-clockwise (CCW) adjustment of the trimpot decreases the output.

Adjustments affect output current, voltage or percentage of duty cycle to the coil. The minimum and maximum output is preset at the factory. However, for optimum performance, they must be adjusted while the equipment is operating.

Although the following adjustments affect the current/voltage or percentage of duty cycle, the best way to adjust the function is to observe the response or speed of the function. The following adjustments affect function response, or speed. There may be some interaction between adjustments, making it necessary to repeat the adjustment in order to achieve the desired response.

“Threshold” Adjustments

Adjusts the initial current flow or duty cycle, affecting the function response or speed when the handle is first moved from the off position. Deflect the handle slowly to the position where the controller first turns on. Adjust the threshold trimpot screw to the point where the controlled function just starts to move, then turn the trimpot screw one, full turn in the counterclockwise direction. This adjustment should be done first.

“Maxout” Adjustments

Adjusts the full stroke current or duty cycle affecting the maximum function response, or speed when the handle is deflected to its full travel. Fully deflect the handle, and adjust the maxout trimpot for maximum desired function response or speed. To obtain proportional resolution, it is important that the function starts to slow down as soon as the handle is moved back from the fully deflected position.

The ideal adjustment occurs when the function just begins to move when the handle is deflected, and the output increases until it reaches its maximum desired response or speed at the end of handle travel.

6.14-2 OEM Controller Troubleshooting

Problem

1. The function will not operate when the handle is moved. The LEDs do not light
 - A. Check that voltage is present at the positive (+) input terminal.
 - B. Check that ground is connected to the negative (-) terminal.
 - C. If there is an in-line fuse, check to see if it is good.
 - D. Check the controller on/off switch and the connectors. Voltage should be present at the (X) terminal when the controller is turned on.
 - E. Check that valve wiring is not shorted to ground. The LEDs will not light.
 - F. Check that valve wiring is not open. The LEDs will light, but the intensity will not vary.
 - G. Check trimpot settings. Fully "CCW" turns output off, "CW" turns output fully on.
2. The function jumps or lurches when turned on.
 - A. Perform "Threshold" adjustment procedures.
3. The function reaches maximum speed before the handle is fully deflected,
 - A. Perform "Maxout" adjustment procedures.
4. The function speed remains constant regardless of the degree of handle deflection.
 - A. Perform "Maxout" adjustment procedures.

IRS Option

1. Function speed reacts too slowly or too quickly in relation to handle deflection.
 - A. Check "IRS" (Ramp) trimpot adjustment. "CW" increases ramp time, "CCW" decreases ramp time.

Integrated Ramp System (IRS)

Provides smooth function response, when reacting to an abrupt change in handle deflection. "CW" rotation of the trimpot increases ramp time and slows the response time. "CCW" decreases ramp time and increases the response time. To increase the ramp time, turn the adjusting screw "CW" a few turns, then move the controller handle abruptly. Continue to adjust until a smooth response is observed. Most controllers have on/off contacts which remove power from the P.C. Board when the handle is returned to the off position. When the handle is abruptly returned to neutral, the output will not ramp down, and the function will stop.

Ramp Thru Off

The P.C. Board should be adjusted as outlined in the IRS adjustment procedure. If the handle is abruptly returned to neutral (OFF) the output will ramp down to off. Ramp time is factory set to 2 seconds, unless otherwise specified.

NOTE

Trimpots should be sealed with nail polish or enamel based paint.



WARNING

Do not use RTV silicone.

6.14-3 OEM Controller Switch Wiring

WIRE CHART		
COLOR	FROM	TO
WHT/RED	STEER LEFT	PIN #1
WHT/GRN	STEER COMMON	PIN #2
WHT	STEER RIGHT	PIN #3
YEL	FORWARD/UP	PIN #4
RED	Vbat	PIN #5
GRY	REVERSE/DOWN	PIN #6
BLU	PROP. OUTPUT	PIN #7
BLK	GROUND (-)	PIN #8
WHT/BLU	ENABLE OUT	PIN #9

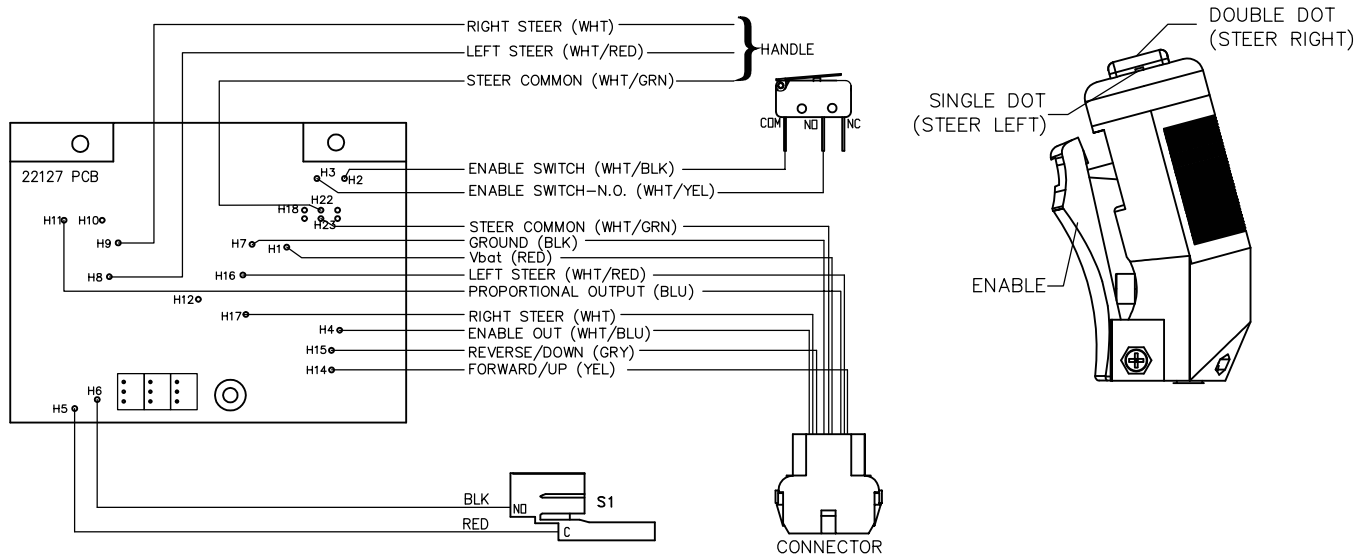

6.14-4 Gate Spring Hinge Adjustment

1. The tension of the spring hinges should be such that when the gate is opened halfway and released, it will close fully and latch.
2. To adjust the tension of the spring hinges, first remove the safety locking screw of each hinge. Retain the screws for reinstallation later.

If Locking Screw Located at the Top or Bottom of the Spring Hinge,

3. To increase the tension, insert a 5/32" hex wrench in the screw socket, and turn the wrench clockwise. To release the tension, depress the hex wrench in the socket, let it rotate counterclockwise, then release the hex wrench.

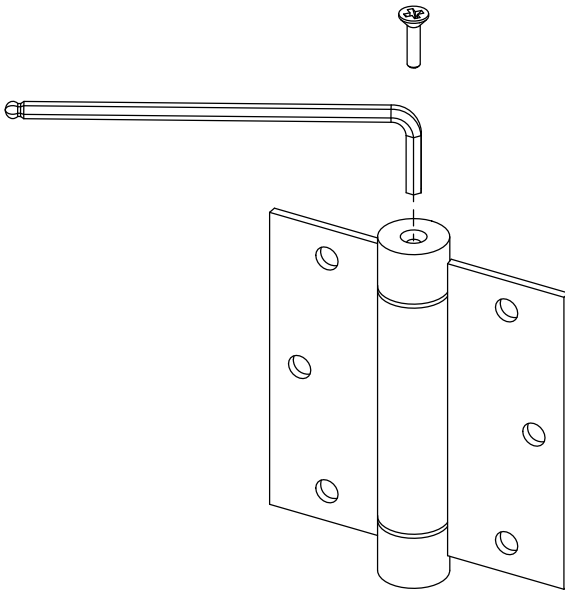

4. Adjust the tension on both hinges until the gate releases and latches from a half open position.
5. Reinstall the safety locking screws into the hinges when tension adjustment is complete.

If Locking Screw Located at the Side of the Spring Hinge,

NOTE

Adjusting the tension on the spring hinge is a two handed operation.

6. To increase the tension, insert a 5/32" hex wrench in the screw socket. Turn the wrench clockwise to desired tension as well as aligning the locking screw hole. Hold the wrench in place, maintaining the selected tension, while reinstalling the locking screw.

NOTE

Ensure the holes inside the hinges are aligned before inserting the locking screw.

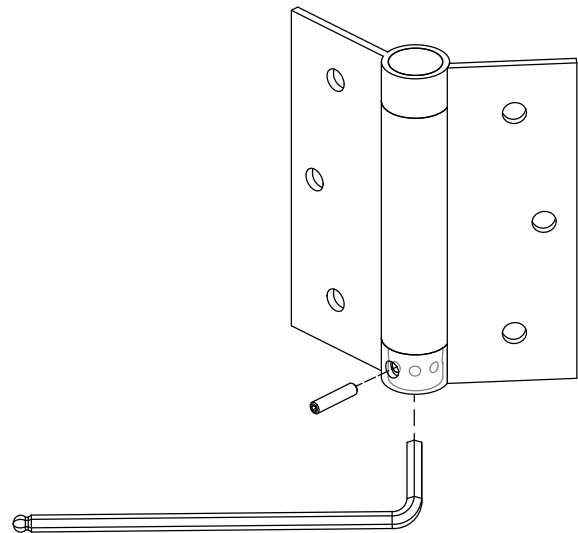

7. Adjust the tension on both hinges until the gate releases and latches from a half open position.

Base**6.15-1 System Relief Pressure Adjustment**

1. Locate the system pressure fitting or quick disconnect port on the main manifold.
2. Install a calibrated 5000 psi gauge to the system pressure fitting or quick disconnect port.
3. At the main manifold, loosen the locknut on the system relief valve R1.
4. Remove black 14 wire from the lift coil.
5. Select lift with the lift/drive select switch on the platform control console.
6. Engaged lift and hold.
7. Observe reading on gauge. Adjust the R1 system relief value listed on the serial number plate. Turning the stem on the relief valve clockwise will increase pressure. Turning the stem counterclockwise will decrease pressure.
8. Release lift function and tighten the locknut.
9. Remove the gauge from system pressure test port.

6.15-2 Lift Pressure Adjustment**NOTE**

Adequate area to raise the platform to full height is required for the following steps.

1. Locate the lift pressure test port on the main manifold.
2. Install a calibrated 3000 psi gauge to the lift pressure quick disconnect port.
3. At the main manifold, loosen the locknut on the lift relief valve R2.
4. Close the manual lowering valve. Use the lift switch at the base control console to raise the platform to full height and hold the lift up switch on.
5. Observe the reading on the gauge. Adjust the R2 relief valve to the value listed on the serial number plate. Turning the stem of the relief valve clockwise will increase pressure. Turning the stem counterclockwise will decrease pressure.
6. Remove the gauge from lift pressure test port.

NOTE

Pressure setting may vary as aerial platform components wear. The lift pressure should be set for rated load only.

6.15-3 Resistor - Voltage Divider

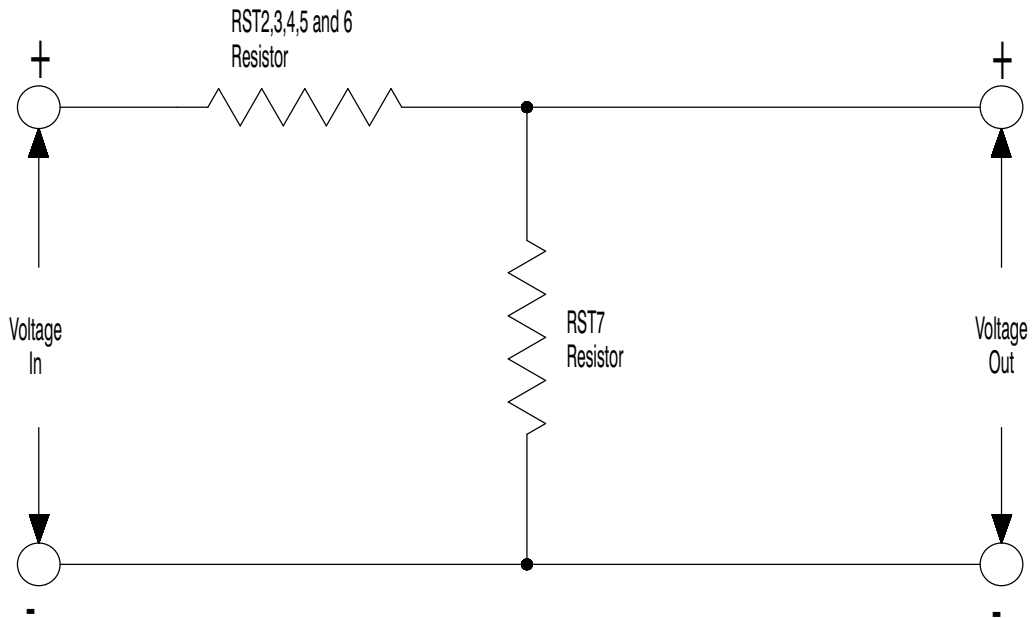

Common Resistor	Resistor	Ohm	Function	Input Voltage*	Output Voltage**
RST7 250 Ohm	RST4	68	Platform lift resistor	4.8	3.8
	RST2	68	Hi speed drive resistor	4.8	3.8
	RST3	360	Elevated drive resistor	4.8	2.0
	RST5	4.75K	Steer only resistor	24	1.2
	RST6	1.2K	Base lift resistor	24	4.1

* 4.8 volts refers to full stroke on the joystick. 24 volts represents a full charge on the battery pack.

** Values given are with all connections tight and free from corrosion + or - 10%.

SKYJACK™

www.skyjack.com